

COLORADO RETAIL FOOD ESTABLISHMENT RULES AND REGULATIONS

6 CCR 1010-2

Adopted by the State Board of Health

Previously amended: Section 3-301, Preventing Contamination from Hands, was amended February 15, 2006, effective March 1, 2007

Most recently amended November 21, 2012, effective March 1, 2013 with the exception of section 3-801 which will become effective July 1, 2013



Colorado Department
of Public Health
and Environment

Authority

**Sections 25-4-1604(1)(b)(I), 25-5-420, 25-1.5-104(1)(g)
and 25-1-108(1)(c)(I), Colorado Revised Statute**

COLORADO DEPARTMENT OF PUBLIC HEALTH
AND ENVIRONMENT
DIVISION OF ENVIRONMENTAL HEALTH AND SUSTAINABILITY
4300 CHERRY CREEK DRIVE SOUTH
DENVER, CO 80246-1530

This Title Page does not constitute an official part of any regulation. Information contained on the title page is provided by the Consumer Protection Division from sources deemed reliable and is solely for informational and historical purposes. This copy of the regulations is provided for the convenience of the user. Official copies of State of Colorado regulations are published by the Secretary of State's office through arrangement with private publishing firm(s). To obtain official copies of state regulations, please contact Weil Publications at 800-877-9345.

TABLE OF CONTENTS

CHAPTER 1.....	1
PURPOSE AND DEFINITIONS	1
1-101 Purpose	1
1-202 Definitions	1
CHAPTER 2.....	17
MANAGEMENT AND PERSONNEL	17
2-1 SUPERVISION.....	17
2-101 Responsibilities.....	17
*2-102 Demonstration.....	17
*2-103 Person in Charge.....	18
2-2 EMPLOYEE HEALTH	19
*2-201 Responsibility of Licensee, Person in Charge, and Employees.....	19
*2-202 Exclusions and Restrictions	21
*2-203 Removal, Adjustment, or Retention of Exclusions and Restrictions	22
2-204 Discharges from the Eyes, Nose and Mouth.....	23
2-3 AUTHORIZED PERSONNEL	23
2-4 PERSONAL CLEANLINESS	23
*2-402 Cleaning Procedure.....	23
*2-403 When to Wash.....	24
*2-404 Hand Antiseptics.....	24
*2-405 Where to Wash.....	24
*2-406 Fingernail Care	24
2-407 Clothing	24
2-408 Jewelry	25
2-5 HYGIENIC PRACTICES	25
*2-501 General.....	25

*2-502	Eating, Drinking, or Using Tobacco	25
2-503	Hair Restraints	25
CHAPTER 3	26
FOOD	26
3-1	CHARACTERISTICS	26
*3-101	General.....	26
3-2	SOURCES AND SPECIFICATIONS.....	26
3-201	Shellfish and Fish.....	26
3-202	Parasite Destruction	27
3-3	SOURCES AND SPECIFICATIONS.....	28
*3-301	Package Integrity	28
*3-302	Hermetically Sealed Food.....	28
*3-303	Dry Milk and Dry Milk Products.....	28
*3-304	Reconstitution of Dry Milk, Dry Milk Products and Non-Dairy Products	29
*3-305	Fluid Milk, Fluid Milk Products, and Frozen Dessert Mix.....	29
*3-306	Wild Mushrooms	29
*3-307	Meat, Poultry, Game Animals and Exotic Species	30
*3-308	Eggs	31
3-309	Ice	31
*3-310	Ice Used as Exterior Coolant, Prohibited as Ingredient.....	31
3-311	Storage or Display of Food in Contact With Water or Ice.....	31
*3-312	Juice	31
*3-313	Whole-Muscle, Intact Beef Steaks.....	32
*3-401	Preventing Contamination from Hands	32
3-402	Glove Use	34
*3-403	Preventing Contamination When Tasting.....	34
*3-404	General.....	34
*3-405	Cross-Contamination Control.....	34
3-406	Packaged and Unpackaged Food - Separation, Packaging, and Segregation	35
*3-407	Pasteurized Eggs, Substitute for Shell Eggs for Certain Recipes	35

3-408	Washing Fruits and Vegetables/Additives/Sulfites	35
3-409	In-Use Utensils, Between Use Storage	36
3-410	Wiping Cloths	36
3-411	Re-Use of Tableware	37
3-412	Refilling Returnables	37
3-413	Food Storage	37
3-414	Food Storage, Prohibited Areas	37
3-415	Food Display	38
3-416	Condiments, Protection	38
*3-417	Consumer Self-Service Operations	38
*3-418	Reservice	38
3-5	DESTRUCTION OF ORGANISMS OF PUBLIC HEALTH CONCERN....	39
*3-501	Temperature	39
*3-502	Cooking Potentially Hazardous Foods (Time/Temperature Control For Safety Foods)	39
*3-503	Non-Continuous Cooking of Raw Animal Foods	41
*3-504	Reheating	42
*3-505	Preparation for Immediate Service	42
3-6	LIMITATION OF GROWTH OF ORGANISMS OF PUBLIC HEALTH CONCERN.....	42
3-601	Thawing	42
3-602	Slacking	43
*3-603	Cooling	43
3-604	Cooling Methods	43
3-605	Time as a Public Health Control	44
*3-606	Specialized Processing Methods	45
*3-607	Reduced Oxygen Packaging	46
3-608	Breading Mixtures	48
3-7	ON-PREMISES LABELING	49
3-701	Labeling	49
3-702	Special Requirements for Highly Susceptible Populations	49
3-8	CONSUMER ADVISORY (Section Effective July 1, 2013)	51

*3-801	Consumption of Animal Foods That Are Raw, Undercooked, or Not Otherwise Processed to Eliminate Pathogens	51
--------	--	----

CHAPTER 4..... 53

WAREWASHING, EQUIPMENT, UTENSILS, AND LINENS..... 53

4-1 MATERIALS FOR CONSTRUCTION AND REPAIR..... 53

4-101	General.....	53
-------	--------------	----

4-102	Equipment Requirements.....	53
-------	-----------------------------	----

4-2 DESIGN AND CONSTRUCTION..... 53

4-201	Food Contact Surfaces	53
-------	-----------------------------	----

4-202	Use Limitations.....	54
-------	----------------------	----

4-203	Nonfood-Contact Surfaces.....	55
-------	-------------------------------	----

4-204	Clean In Place (CIP) Equipment.....	55
-------	-------------------------------------	----

4-205	“V” Threads, Use Limitation	56
-------	-----------------------------------	----

4-206	Hot-Oil Filtering Equipment.....	56
-------	----------------------------------	----

4-207	Bearings and Gear Boxes, Leakproof	56
-------	--	----

4-208	Beverage Tubing, Separation.....	56
-------	----------------------------------	----

4-209	Ice Units, Separation of Drains.....	56
-------	--------------------------------------	----

4-210	Condenser Unit, Separation	56
-------	----------------------------------	----

*4-211	Molluscan Shellfish Tanks.....	56
--------	--------------------------------	----

4-212	Ventilation and Ventilation Hood Systems.....	57
-------	---	----

4-3 LOCATION AND INSTALLATION 58

4-301	Equipment, and Storage Cabinets, Contamination Prevention	58
-------	---	----

4-302	Fixed Equipment, Spacing or Sealing.....	58
-------	--	----

4-4 EQUIPMENT AND UTENSIL CLEANING AND SANITIZATION - TESTING DEVICES 61

4-401	Temperature Measuring Devices	61
-------	-------------------------------------	----

4-402	Testing Devices.....	61
-------	----------------------	----

4-403	Manual Cleaning and Sanitization.....	62
-------	---------------------------------------	----

4-404	Mechanical Cleaning and Sanitization.....	64
-------	---	----

4-405	Drainboard and Dishtable Requirements	66
-------	---	----

4-406	Drying.....	67
-------	-------------	----

4-407	Food-Contact Surfaces of Equipment and Utensils	67
-------	---	----

4-408	Nonfood-Contact Surfaces.....	68
4-409	Dry Equipment Cleaning Methods	68
4-5	LAUNDRY FACILITIES	69
4-501	Laundry Facilities	69
4-6	EQUIPMENT AND UTENSIL HANDLING AND STORAGE	69
4-601	Equipment and Utensil Storage	69
4-602	Single-Service and Single-Use Articles.....	69
4-603	Preset Tableware.....	70
CHAPTER 5.....		71
WATER, PLUMBING, AND WASTE		71
5-1 WATER SUPPLY		71
*5-101	General.....	71
*5-102	System Flushing and Disinfection	71
*5-103	Bottled Drinking Water	71
*5-104	Transportation.....	72
*5-105	Emergency Alternative Water Supply	72
*5-106	Non-Drinking Water	72
*5-107	Pressure and Temperature.....	72
*5-108	Hot Water.....	72
*5-108	Steam	72
5-2 PLUMBING SYSTEM.....		73
5-201	General.....	73
*5-202	Backflow	73
5-203	Conditioning Device, Design.....	74
5-204	Grease Trap / Grease Interceptor	74
5-205	Food Waste Grinders/Garbage Disposals	74
*5-206	Drainage Of Equipment	75
5-207	Drainage System Installation	76
5-208	Handwashing Lavatory, Water Temperature, and Flow	76
5-209	Toilets and Urinals.....	77
5-210	Utility Facility.....	78

*5-211	Sewage.....	78
*5-212	Water Reservoir of Fogging Devices, Cleaning.....	78
5-3	REFUSE, RECYCLABLES, AND RETURNABLES.....	79
5-301	Containers.....	79
5-302	Storage.....	79
5-303	Disposal.....	79
5-304	Storage Areas, Redeeming Machines, Equipment, and Receptacles, Location.....	80
CHAPTER 6.....		81
PHYSICAL FACILITIES.....		81
6-1 FLOORS.....		81
6-101	Floor Construction.....	81
6-102	Floor Carpeting.....	81
6-103	Utility Line Installation.....	81
6-104	Floor Junctures.....	81
6-105	Prohibited Floor Covering.....	81
6-106	Mats and Duckboards.....	81
6-2 WALLS AND CEILINGS.....		82
6-201	Construction.....	82
6-202	Attachments, Exposed Construction.....	82
6-3 LIGHTING.....		82
6-301	Light Intensity.....	82
6-302	Light Bulbs, Protective Shielding.....	83
6-4 OPERATION AND MAINTENANCE.....		83
6-401	Cleaning Physical Facilities.....	83
6-402	Cleaning Equipment Storage.....	83
6-5 PREMISES.....		83
6-501	General.....	83
6-502	Living Areas.....	84
6-503	Dressing Rooms and Locker Areas.....	84

CHAPTER 7.....	85
POISONOUS OR TOXIC MATERIALS.....	85
7-1 LABELING AND IDENTIFICATION	85
*7-101 Identifying Information, Prominence.....	85
*7-102 Working Containers.....	85
*7-103 Separation	85
*7-104 Restriction.....	85
*7-105 Use of Materials.....	85
*7-106 Food Containers.....	86
*7-107 Chemicals for Washing Fruits and Vegetables, Criteria.....	86
*7-108 Boiler Water Additives, Criteria.....	86
*7-109 Drying Agents, Criteria.....	86
*7-110 Personal Medications.....	86
*7-111 First Aid Supplies	86
 CHAPTER 8.....	 87
INSECT, RODENT AND ANIMAL CONTROL	87
8-1 PREVENTION	87
8-101 Outer Openings, Protected.....	87
8-102 Controlling Pests.....	87
8-103 Insect Control Devices, Design and Installation.....	87
*8-104 Pesticide Application	88
*8-105 Removing Birds, Insects, Rodents, and Other Pests.....	88
*8-106 Prohibiting of Animals.....	88
 CHAPTER 9.....	 90
MOBILE RETAIL FOOD ESTABLISHMENTS OR PUSHCARTS	90
9-1 MOBILE RETAIL FOOD ESTABLISHMENT	90
9-101 General.....	90
9-102 Exemptions	90
9-103 Single-service Articles.....	90
9-104 Water System.....	91

9-105	Wastewater Retention	92
*9-106	Handwashing Facilities	92
9-107	Commissary	92
9-108	Additional Requirements	94
CHAPTER 10	95
TEMPORARY RETAIL FOOD ESTABLISHMENTS	95
10-1 TEMPORARY RETAIL FOOD ESTABLISHMENTS	95
10-101	General.....	95
10-102	Operations.....	95
10-103	Commissary	95
10-104	Minimum Event Site Equipment Requirements	96
*10-105	Ice	96
10-106	Single-Service Articles	96
*10-107	Water.....	97
10-108	Wet Storage	97
*10-109	Waste	97
*10-110	Handwashing	97
*10-111	Screening and Enclosures	97
*10-112	Grounds.....	97
*10-113	Overhead Protection	97
CHAPTER 11	98
COMPLIANCE PROCEDURES	98
11-1 COMPLIANCE	98
11-101	General.....	98
11-102	Issuance of License or Certificate of License.....	98
11-103	License Renewal	98
11-104	Judicial Review.....	98
11-105	Closure Without Suspension.....	99
11-106	Injunctive Relief	99
11-2 INSPECTIONS	99
11-201	Inspection Frequency.....	99

11-202	Access	99
11-203	Report of Inspections	100
11-204	Correction of Violations	100
11-205	Inspection Report.....	101
11-3	CONDEMNATION AND EMBARGO OF FOOD	103
11-301	General.....	103
11-302	Voluntary Condemnation.....	103
11-303	Embargo Placement.....	103
11-304	Embargo Release	104
11-305	Condemnation of Product.....	104
11-4	REVIEW OF PLANS.....	104
11-401	Submission of Plans.....	104
11-402	Contents of Plans and Specifications.....	104
11-403	Contents of a HACCP Plan.....	104
11-404	Pre-Operational Inspection.....	105
11-5	PROCEDURE WHEN INFECTION IS SUSPECTED	105
11-501	General.....	105
11-6	VARIANCE PROCEDURE	106
11-601	Variance Procedure.....	106
11-7	REFERENCE CITATIONS	107
11-701	General.....	107
11-702	Safe Materials	107
11-703	Food Protection Act.....	107
11-704	Milk Standards.....	107
11-705	Ventilation Requirements	107
11-706	Code of Federal Regulations.....	108
11-707	Plumbing Requirements.....	108
11-708	Administrative Statutes.....	108
11-709	American National Standards Institute (ANSI).....	108

APPENDICES

<i>Appendix A - Potentially Hazardous Foods.....</i>	<i>A 1-8</i>
<i>Appendix B – Safe Materials Colorado Pure Food and Drug Law.....</i>	<i>B 1</i>
<i>Appendix C – Worksheet for Calculating Minimum Hot Water Requirements.....</i>	<i>C 1-9</i>
<i>Appendix D – Specific Usage Additives.....</i>	<i>D 1-3</i>
<i>Appendix E – Lubricants.....</i>	<i>E 1-4</i>
<i>Appendix F – Sanitizers</i>	<i>F 1</i>
<i>Appendix G – HACCP Guidelines</i>	<i>G 1-33</i>
<i>Appendix H – Retail Food Sanitation Act.....</i>	<i>H 1-3</i>
<i>Appendix I – Equipment Investigation Report</i>	<i>I 1-4</i>

CHAPTER 1

PURPOSE AND DEFINITIONS

1-101 Purpose

The following rules and regulations shall be applied for the protection of public health.

The purpose of this Regulation is to safeguard public health and provide to consumers food that is safe and unadulterated. This Regulation establishes definitions; sets standards for management and personnel, food operations and equipment and facilities; and provides for food establishment plan review, license issuance, inspections, employee restriction and enforcement. This Regulation is intended to be the standard for the Department and its authorized agents and employees, to be applied uniformly by all parties.

1-202 Definitions

A. The following terms are defined for the purposes of the rules and regulations.

1. **“Accredited Program”** means a food protection manager certification program that has been evaluated and listed by an accrediting agency as conforming to the national standards for organizations that certify individuals. Accredited Program does not refer to training functions or educational programs.
2. **“Adulterated”** means as stated in the Colorado Pure Food and Drug Act, section 25-5-4, C.R.S.
3. **“Allergens”** - See major food allergens definition 1-202(66).
4. **“Approved”** means acceptable to the Department, based on determination of conformity with principles, practices, and generally recognized standards that protect public health.
5. **“Asterisk (*)”** means any section or portion thereof denoted with an * indicates it is a critical item.
6. **“Asymptomatic”**:
 - a. Means without obvious symptoms; not showing or producing indications of a disease or other medical condition, such as an individual infected with a pathogen but not exhibiting or producing any signs or symptoms of vomiting, diarrhea, or jaundice.
 - b. Includes not showing symptoms because symptoms have resolved or subsided, or because symptoms never manifested.
7. **“ a_w ”** means water activity which is a measure of the free moisture in a food, is the quotient of the water vapor pressure of the substance divided by the vapor pressure of pure water at the same temperature, and is indicated by the symbol a_w .
8. **“Balut”** means an embryo inside a fertile egg that has been incubated for a period sufficient for the embryo to reach a specific stage of development after which it is removed from incubation before hatching.
9. **“Bulk Foods”** means foods as defined in section 25-4-1302, C.R.S.
10. **“Catering Operation”** means a retail food establishment that provides a contracted, prearranged number of meals and/or food products that are prepared at a licensed retail

food establishment for service and consumed at the same or another prearranged offsite location and not available for individual purchase.

11. **“Certified Food Protection Manager”** means a person in charge that is certified by an accredited program for food protection.
12. **“CFR”** means Code of Federal Regulations. Citations in this Code to the CFR refer sequentially to the Title, Part, and Section numbers, such as 40 CFR 180.194 refers to Title 40, Part 180, Section 194.
13. **“Clean In Place (CIP)”** means cleaned in place by the circulation or flowing by mechanical means through a piping system of a detergent solution, water rinse, and sanitizing solution onto or over equipment surfaces that require cleaning, such as the method used, in part, to clean and sanitize a frozen dessert machine.

CIP does not include the cleaning and sanitization of equipment such as band saws, cutting boards, slicers or mixers that are subjected to in-place manual cleaning without the use of an automated CIP system.
14. **“Commercial Design”** means equipment that is certified or classified by an American National Standards Institute (ANSI) accreditation certification program, such as the National Sanitation Foundation (NSF), Underwriters Laboratories (UL) sanitation standards, Environmental Testing Laboratories, Inc. (ETL) sanitation standards, Baking Industry Sanitation Standards Committee (BISSC), or other comparable design criteria as approved by the Department during a standardized equipment review.
15. **“Commingle”** means:
 - a. To combine shellstock harvested on different days or from different growing areas as identified on the tag or label, or
 - b. To combine shucked shellfish from containers with different container codes or different shucking dates.
16. **“Comminuted”** means reduced in size by methods including chopping, flaking, grinding, or mincing. This includes fish or meat products that are reduced in size and restructured or reformulated such as gefilte fish, formed roast beef, gyros, ground beef, and sausage; and a mixture of two or more types of meat which have been reduced in size and combined, such as sausages made from two or more meats.
17. **“Commissary”** means a facility that is approved by the Department as a base of operation for a temporary retail food establishment, pushcart, or mobile food establishment where food, containers, or supplies are kept, handled, prepared, packaged or stored and is constructed and operated in compliance with the Rules and Regulations.
18. **“Conditional Employee”** means a potential food employee to whom a job offer is made, conditional on responses to subsequent medical questions or examinations designed to identify potential food employees who may be suffering from a disease that can be transmitted through food and done in compliance with Title 1 of the Americans with Disabilities Act of 1990.
19. **“Contamination”** means exposure to or contact with a contaminant. Actions that may contaminate or cause contamination include: unsanitary food-contact surfaces, coughing, sneezing, spitting, unnecessary handling, flooding, draining, leakage from overhead pipes, and condensation. “Contaminant” means a substance, organism, or entity that might cause disease or threaten public health, and includes soil, dust, insects, rodents, other pests, and poisonous or toxic materials.

20. **“Confirmed Disease Outbreak”** means a foodborne disease outbreak in which laboratory analysis of appropriate specimens identifies a causative agent and epidemiological analysis implicates the food as the source of the illness.
21. **“Corrosion-Resistant Materials”** means a material that maintains acceptable surface cleanability characteristics under prolonged influence of the food to be contacted, the normal use of cleaning compounds and sanitizing solutions, and other conditions of the use environment.
22. **“Critical Control Point”** means any point in a food preparation process at which loss of control might result in an unacceptable consumer health risk.
23. **“Critical Item”** means a provision of these rules and regulations that, if in noncompliance, is more likely than other violations to contribute to food contamination, illness, or an environmental health hazard. These are items denoted in these rules and regulations with an asterisk *.
24. **“Critical Limit”** means the maximum or minimum value to which a physical, biological, or chemical parameter must be controlled at a critical control point to minimize the risk that the identified food safety hazard may occur.
25. **“Cross-Connection”** means any connection or arrangement, physical or otherwise, between a potable water supply system and any plumbing fixture or any tank, receptor, equipment or device, to which it may be possible for non-potable, used, unclean, polluted or contaminated water, or other substances, to enter any part in such potable water system under any condition.
26. **“Cross Contamination”** means the transfer of harmful bacteria to food from other foods, such as raw or undercooked animal products, to cutting boards, utensils, etc. if they are not handled properly.
27. **“Cut Leafy Greens”** means fresh leafy greens whose leaves have been cut, shredded, sliced, chopped, or torn. The term "leafy greens" includes iceberg lettuce, romaine lettuce, leaf lettuce, butter lettuce, baby leaf lettuce (i.e., immature lettuce or leafy greens), escarole, endive, spring mix, spinach, cabbage, kale, arugula and chard. The term "leafy greens" does not include herbs such as cilantro or parsley.
28. **“Department”** means the Colorado Department of Public Health and Environment, and its authorized employees as well as any county or district board of health who have been delegated the powers and duties described in Sections 25-4-1604(1)(a), (c), (d) and (h) C.R.S.
29. **“Drinking Water”**
 - a. **"Drinking Water"** means water that meets criteria as specified in section 25-1.5-2, C.R.S., *Colorado Primary Drinking Water Regulations*
 - b. **"Drinking Water"** is traditionally known as "potable water."
 - c. **"Drinking Water"** includes the term "water" except where the term used connotes that the water is not potable, such as "boiler water," "mop water," "rainwater," "wastewater," and "nondrinking" water.
30. **“Dry Storage Area”** means a room or area designated for the storage of packaged or containerized bulk food that is not potentially hazardous (time and temperature control for food safety) and dry goods such as single-service items.

31. **“Easily Cleanable”** means surfaces are readily accessible and fabricated of such materials and finishes that residue can be effectively removed by normal cleaning methods.
32. **“Egg”** means the shell egg of avian species such as chicken, duck, goose, guinea, quail, ratites or turkey.
- “Egg”** does not include:
- a. A balut;
 - b. The egg of reptile species such as alligator; or
 - c. An egg product.
33. **“Egg Product”**
- a. **“Egg Product”** means all, or a portion of, the contents found inside eggs separated from the shell and pasteurized in a food processing plant, with or without added ingredients, intended for human consumption, such as dried, frozen or liquid eggs
 - b. **“Egg Product”** does not include food which contains eggs only in a relatively small proportion such as cake mixes.
34. **“Employee”** means the licensee, person in charge, food employee, person having supervisory or management duties, person on the payroll, family member, volunteer, person performing work under contractual agreement, and any person working in a food establishment.
35. **“Enterohemorrhagic Escherichia coli”** means E. coli which cause hemorrhagic colitis, meaning bleeding enterically or bleeding from the intestine. The term is typically used in association with E. coli that have the capacity to produce Shiga toxins and to cause attaching and effacing lesions in the intestine. EHEC is a subset of Shiga toxin-producing E. coli (STEC), whose members produce additional virulence factors. Infections with EHEC may be asymptomatic but are classically associated with bloody diarrhea (hemorrhagic colitis) and hemolytic uremic syndrome (HUS) or thrombotic thrombocytopenic purpura (TTP). Examples of serotypes of EHEC include: E. coli O157:H7; E. coli O157:NM; E. coli O26:H11; E. coli O145:NM; E. coli O103:H2; or E. coli O111:NM. Also see Shiga toxin-producing E. coli.
36. **“EPA”** means the U.S. Environmental Protection Agency
37. **“Equipment”** means an article used in the operation of a food establishment, such as, but not limited to a freezer, grinder, hood, ice maker, meat block, mixer, oven, reach-in refrigerator, range, scale, sink, slicer, stove, table, temperature measuring device, or warewashing machine.
- Equipment does not include items used for handling or storing large quantities of packaged foods received from a supplier in a cased or overwrapped lot, such as hand trucks, forklifts, dollies, pallets, racks, and skids.
38. **“Exclude”** means to prevent a person from working as an employee in a food establishment or entering a food establishment as an employee.
39. **“Extensively Remodeled”** means any major alteration of an existing configuration in a food establishment which might affect the food operation that results in one or more of the following conditions:

- a. Seating capacity, including service provided anywhere on the premises, is increased by a minimum of 15 seats or 20 percent whichever is greater in either a single construction project or an incremental series of construction activities;
 - b. Alterations or revisions involving retail food establishments or related equipment that require a building or construction permit by local building authorities. Routine maintenance, repairs or cosmetic changes shall not be defined as extensive remodeling;
 - c. Changes or alterations made in the nonpublic areas that result in a reduction or increase of total space by 25 percent or more; or
 - d. The facility's capabilities to handle food, equipment, and utensils in a sanitary manner have been diminished due to a food process or significant menu change that introduces new risks for foodborne illness.
40. **“Fish”**
- a. **“Fish”** means fresh or saltwater finfish, crustaceans and other forms of aquatic life (including alligator, frog, aquatic turtle, jellyfish, sea cucumber, and sea urchin and the roe of such animals) other than birds or mammals, and all mollusks, if such animal life is intended for human consumption.
 - b. **“Fish”** includes an edible human food product derived in whole or in part from fish, including fish that have been processed in any manner.
41. **“Food”** means a raw, cooked, or processed edible substance, ice, beverage, or ingredient used or intended for use or for sale in whole or in part for human consumption.
42. **“Foodborne Disease Outbreak”** means an incident in which:
- a. Two or more otherwise unrelated persons experience a similar illness after ingestion of a common food; and
 - b. Epidemiological analysis implicates the food as the source of the illness.
43. **“Foodborne Illness Risk Factor”** means the five most significant contributing factors, behaviors and practices, which have been determined to contribute directly to foodborne illness within retail food establishments by the Centers for Disease Control and Prevention. The five categories are:
- a. Food from unsafe sources
 - b. Inadequate cooking
 - c. Improper holding temperatures
 - d. Contaminated equipment
 - e. Poor personal hygiene
44. **“Food-Contact Surfaces”** means those surfaces of equipment and utensils with which food normally comes in contact, and those surfaces from which food may drain, drip, or splash back onto surfaces in contact with food. This excludes ventilation hoods.
45. **“Food Employee”** means an individual who works directly with unpackaged food, food equipment or utensils, or food-contact surfaces. A food employee does not include employees who are hostesses, servers and/or others who do not directly handle food or clean equipment and utensils.

46. **“Food Preparation”** means packaging, processing, assembling, portioning, or any operation that changes the form, flavor, or consistency of food, but does not include trimming of produce for display prior to sale.
47. **“Food Processing Establishment”** means an establishment in which food is processed, prepared, packaged, and distributed for human consumption and approved by the Department.
48. **“Game Animal”**
- a. **“Game Animal”** means an animal, the products of which are food, that is not classified as livestock, sheep, swine, goat, horse, mule, or other equine in 9 CFR 301.2 Definitions, or as poultry, or fish.
 - b. **“Game Animal”** includes mammals such as reindeer, elk, deer, antelope, water buffalo, bison, rabbit, squirrel, opossum, raccoon, nutria, or muskrat, and nonaquatic reptiles such as land snakes.
 - c. **“Game Animal”** does not include ratites such as emu, ostrich and rhea
49. **“Ground Beef”** means meat that is derived from the voluntary striated muscle of beef, with a maximum of thirty percent total fat by weight, with no water, phosphates, extenders, or binders added.
50. **“HACCP Plan”** means a written document that delineates the formal procedures for following the Hazard Analysis Critical Control Point principles.
51. **“Handwashing Sink”** means a lavatory, a basin or vessel for washing, a wash basin, or a plumbing fixture especially placed for use in personal hygiene and designed for the washing of the hands.
52. **“Hazard”** means a biological, chemical, or physical property that might cause an unacceptable consumer health risk.
53. **“Health Practitioner”** means a physician licensed to practice medicine, or if allowed by law, a nurse practitioner, physician assistant, or similar medical professional.
54. **“Hermetically Sealed Container”** means a container designed and intended to be secure against the entry of microorganisms and to maintain the commercial sterility of its content after processing.
55. **“Highly Susceptible Population”** means persons who are more likely than other people in the general population to experience foodborne disease because they are immunocompromised, preschool age children, or older adults; and they obtain food at a facility that provides services such as custodial care, health care, or assisted living, such as a child or adult day care center, kidney dialysis center, hospital or nursing home, or nutritional or socialization services such as a senior center.
56. **“Hygroscopic”** means readily taking up and retaining moisture.
57. **“Imminent Health Hazard”** means a significant threat or danger to health that is considered to exist when there is evidence sufficient to show that a product, practice, circumstance, or event creates a situation that requires immediate correction or cessation of operation to prevent injury or illness based on:
- a. The number of potential injuries or illnesses, and
 - b. The nature, severity, and duration of the anticipated injury or illness.

58. **“Injected”** means manipulating meat to which a solution has been introduced into its interior by processes that are referred to as "injecting," "pump marinating," or "stitch pumping".
59. **“Inspection”** means an inspection of a retail food establishment conducted by the department or a county or district board of health to ensure compliance by such establishment with these rules.
60. **“Juice”**
- a. **“Juice”** means the aqueous liquid expressed or extracted from one or more fruits or vegetables, purées of the edible portions of one or more fruits or vegetables, or any concentrates of such liquid or purée.
 - b. **“Juice”** does not include, for purposes of HACCP, liquids, purées, or concentrates that are not used as beverages or ingredients of beverages.
61. **“Kitchenware”** means all multi-use utensils other than tableware, used in the storage, preparation, transportation or serving of food.
62. **“Law”** means applicable local, state, and federal statutes, regulations, and ordinances.
63. **“License”** means a grant to a license to operate a retail food establishment.
64. **“Licensee”** means a person that is licensed or who holds a certificate of license and is responsible for the lawful operation of a retail food establishment.
65. **“Linens”** means fabric items such as cloth hampers, cloth napkins, tablecloths, wiping cloths, and work garments including cloth gloves.
66. **“Major Food Allergen”**
- a. **“Major Food Allergen”** means: Milk, egg, fish (such as bass, flounder, cod, and including crustacean shellfish such as crab, lobster, or shrimp), tree nuts (such as almonds, pecans, or walnuts), wheat, peanuts, and soybeans; or a food ingredient that contains protein derived from a food, as specified in this paragraph.
 - b. **“Major Food Allergen”** does not include: Any highly refined oil derived from a food specified in paragraph (a) of this definition and any ingredient derived from such highly refined oil; or any ingredient that is exempt under the petition or notification process specified in the Food Allergen Labeling and Consumer Protection Act of 2004 (Public Law 108-282).
67. **“Meat”** means the flesh of animals used as food including the dressed flesh of cattle, swine, sheep, or goats and other edible animals, except fish, poultry, and wild game animals.
68. **“Mechanically Tenderized”**
- a. **“Mechanically Tenderized”** means manipulating meat with deep penetration by processes which may be referred to as "blade tenderizing," "jaccarding," "pinning," "needling," or using blades, pins, needles or any mechanical device.
 - b. **“Mechanically Tenderized”** does not include processes by which solutions are injected into meat.
69. **“mg/L”** means milligrams per liter, which is the metric equivalent of parts per million (ppm).

70. **“Mobile Retail Food Establishment”** means a retail food establishment that is a wheeled vehicle or trailer that is readily moveable and designed for the service of food from the interior of the unit that is intended to physically report to and operate from a commissary for servicing, restocking, and maintenance each operating day.
71. **“Molluscan Shellfish”** means any edible species of fresh or frozen oysters, clams, mussels, and scallops or edible portions thereof, except when the scallop product consists only of the shucked adductor muscle.
72. **“New Retail Food Establishment”** means a facility that makes its initial application as a retail food establishment, a facility that changes its physical location, a newly constructed or extensively remodeled establishment, or when there is a change in the Department of Revenue Sales Tax ID Number.
73. **“Nonfood-Contact Surfaces”** means all surfaces other than food-contact surfaces.
74. **“Non-Continuous Cooking”**:
- a. Means the cooking of food in a food establishment using a process in which the initial heating of the food is intentionally halted so that it may be cooled and held for complete cooking at a later time prior to sale or service such as, but not limited to, the par cooking of bacon.
 - b. Does not include cooking procedures that only involve temporarily interrupting or slowing an otherwise continuous cooking process.
75. **“Non-Critical Item”**:
- a. Means a provision in this Code that is not designated as a critical item.
 - b. Does not include cooking procedures that only involve temporarily interrupting or slowing an otherwise continuous cooking process.
76. **“Packaged”**
- a. Means bottled, canned, cartoned, securely bagged, or securely wrapped, whether packaged in a food establishment or a food processing plant.
 - b. **“Packaged”** does not include a wrapper, carry-out box, or other nondurable container used to containerize food with the purpose of facilitating food protection during service and receipt of the food by the consumer.
77. **“Person”** means an association, a corporation, individual, partnership, other legal entity, government, or governmental subdivision or agency.
78. **“Person In Charge”** means the individual present at a retail food establishment who is responsible for the operation at the time of inspection. If no individual is responsible, then any employed person present is the person in charge.
79. **“Personal Care Items”** means items or substances that may be poisonous, toxic, or a source of contamination which are used to maintain or enhance a person's health, hygiene, or appearance, such as medicines, first aid supplies, cosmetics, toiletries such as lotion, toothpaste and mouthwash.
80. **“pH”** means the measure of the degree of acidity or alkalinity of a solution. pH between 0 and 7 indicate acidity and pH between 7 and 14 indicate alkalinity. The value for pure distilled water is 7, which is considered neutral.

81. **“Physical Facilities”** means the structure and interior surfaces of a retail food establishment including floors, walls, ceilings, lighting, and premises, including, but not limited to accessories such as soap and towel dispensers and attachments such as light fixtures and heating or air conditioning system vents.
82. **“Poisonous or Toxic Materials”** means substances not intended for ingestion and are included in four categories:
- Cleaners and sanitizers, which include cleaning and sanitizing agents and agents such as caustics, acids, drying agents, polishes, and other chemicals;
 - Pesticides, which include substances such as insecticides and rodenticides;
 - Substances necessary for the operation and maintenance of the establishment such as nonfood grade lubricants and personal care items that may be deleterious to health; and
 - Substances that are not necessary for the operation and maintenance of the establishment and are on the premises for retail sale, such as petroleum products and paints.
83. **“Potentially Hazardous Food (Time/Temperature Control for Safety Food)”**
- “Potentially Hazardous Food (time/temperature control for safety food)”** means a food that requires time/temperature control for safety (TCS) to limit pathogenic microorganism growth or toxin formation.
 - “Potentially Hazardous Food (time/temperature control for safety food)”** includes:
 - A food of animal origin that is raw or heat-treated; a food of plant origin that is heat-treated or consists of raw seed sprouts, cut melons, cut leafy greens, cut tomatoes or mixtures of cut tomatoes that are not modified in a way so that they are unable to support pathogenic microorganism growth or toxin formation, or garlic-in-oil mixtures that are not modified in a way so that they are unable to support pathogenic microorganism growth or toxin formation; and
 - Except as specified in Subparagraph (c)(4) of this definition, a food that because of the interaction of its a_w and pH values is designated as Product Assessment Required (PA) in Table A or B of this definition.

Table A. Interaction of pH and a_w for control of spores in food heat-treated to destroy vegetative cells and subsequently packaged			
a_w values	pH values		
	4.6 or less	> 4.6 - 5.6	> 5.6
≤ 0.92	non-PHF*/non-TCS food**	non-PHF/non-TCS food	non-PHF/non-TCS food
>0.92 - .95	non-PHF/non-TCS food	non-PHF/non-TCS food	PA***
>0.95	non-PHF/non-TCS food	PA	PA
* PHF means Potentially Hazardous Food ** TCS food means Time/Temperature Control for Safety food *** PA means Product Assessment required			

Table B. Interaction of pH and aw for control of vegetative cells and spores in food not heat-treated or heat-treated but not packaged				
aw values	pH values			
	<4.2	4.2 - 4.6	>4.6 - 5.0	>5.0
<0.88	non-PHF*/ non-TCS food**	non-PHF/ non-TCS food	non-PHF/ non-TCS food	non-PHF/ non-TCS food
0.88 - 0.90	non-PHF/ non-TCS food	non-PHF/ non-TCS food	non-PHF/ non-TCS food	PA***
>0.90 - 0.92	non-PHF/ non-TCS food	non-PHF/ non-TCS food	PA	PA
>0.92	non-PHF/ non-TCS food	PA	PA	PA

* PHF means Potentially Hazardous Food
** TCS food means Time/Temperature Control for Safety food
*** PA means Product Assessment required

c. **"Potentially Hazardous Food (time/temperature control for safety food)"** does not include:

- (1) An air-cooled hard-boiled egg with shell intact, or an egg with shell intact that is not hard-boiled, but has been pasteurized to destroy all viable salmonellae; and
- (2) A food in an unopened hermetically sealed container that is commercially processed to achieve and maintain commercial sterility under conditions of non-refrigerated storage and distribution.
- (3) A food that because of its pH or a_w value, or interaction of a_w and pH values, is designated as a non-PHF/non-TCS food in Table A or B of this definition;
- (4) A food that is designated as Product Assessment Required (PA) in Table A or B of this definition and has undergone a Product Assessment showing that the growth or toxin formation of pathogenic microorganisms that are reasonably likely to occur in that food is precluded due to:
 - (a) Intrinsic factors including added or natural characteristics of the food such as preservatives, antimicrobials, humectants, acidulants, or nutrients,
 - (b) Extrinsic factors including environmental or operational factors that affect the food such as packaging, modified atmosphere such as reduced oxygen packaging, shelf life and use, or temperature range of storage and use, of
 - (c) a combination of intrinsic and extrinsic factors; or

- (5) A food that does not support the growth or toxin formation of pathogenic microorganisms in accordance with one of the subparagraphs (c)(1)-(4) of this definition even though the food may contain a pathogenic microorganism or chemical or physical contaminant at a level sufficient to cause illness or injury.
84. **“Poultry”** means any domesticated bird such as chickens, turkeys, ducks, geese, or guineas or squabs and any migratory waterfowl, game bird, such as pheasant, partridge, quail, grouse, or pigeon.
85. **“Premises”** means the physical facility, its contents, and the contiguous land or property and its facilities and contents that may impact retail food establishment personnel, facilities, or operations.
86. **“Primal Meat Cuts”** means a basic major cut into which carcasses and sides of meat are separated, such as a beef round, pork loin, lamb flank, or veal breast.
87. **“Private Boarding Houses”** means a house at which meals, or meals and lodging, may be obtained for payment.”
- “Private Boarding Houses”** does not include:
- a. Hotels
 - b. Motels
 - c. Homeless shelters
 - d. Youth hostel
 - e. Other commercial facilities providing lodging and/or meals for the indigent population whether or not there is a charge for such food and/or lodging.
88. **“Pushcart”** means a retail food establishment that is a non-motorized, unit designed so foods are served from the exterior of the unit, and which is intended to physically report to and operate from a commissary for servicing, restocking and maintenance each operating day.
89. **“Ratite”** means a flightless bird such as an emu, ostrich, or rhea.
90. **“Ready-to-Eat Food”** means food that is edible without further washing, cooking, or additional preparation and that is reasonably expected to be consumed in that form. Ready-to-eat food does not include whole, raw fruits and vegetables that are intended for washing by the consumer before consumption
91. **“Reconstituted”** means dehydrated food products recombined with water or other liquids.
92. **“Reduced Oxygen Packaging”**
- a. **“Reduced Oxygen Packaging”** means:
 - (1) The reduction of the amount of oxygen in a package by removing oxygen; displacing oxygen and replacing it with another gas or combination of gases; or otherwise controlling the oxygen content to a level below that normally found in the atmosphere (approximately 21% at sea level); and

- (2) A process as specified in section (a)(1) of this definition that involves a food for which the hazards *Clostridium botulinum* or *Listeria monocytogenes* require control in the final packaged form.

b. **" Reduced Oxygen Packaging"** includes:

- (1) Vacuum packaging, in which air is removed from a package of food and the package is hermetically sealed so that a vacuum remains inside the package;
- (2) Modified atmosphere packaging, in which the atmosphere of a package of food is modified so that its composition is different from air but the atmosphere may change over time due to the permeability of the packaging material or the respiration of the food. Modified atmosphere packaging includes reduction in the proportion of oxygen, total replacement of oxygen, or an increase in the proportion of other gases such as carbon dioxide or nitrogen;
- (3) Controlled atmosphere packaging, in which the atmosphere of a package of food is modified so that until the package is opened, its composition is different from air, and continuous control of that atmosphere is maintained, such as by using oxygen scavengers or a combination of total replacement of oxygen, nonrespiring food, and impermeable packaging material;
- (4) Except as specified in section (c), Cook chill packaging, in which cooked food is hot filled into impermeable bags which have the air expelled and are then sealed or crimped closed, the bagged food is rapidly chilled and refrigerated at temperatures that inhibit the growth of psychrotrophic pathogens; or
- (5) Sous vide packaging, in which raw or partially cooked food is vacuum packaged in an impermeable bag, cooked, rapidly chilled, and refrigerated at temperatures that inhibit the growth of psychrotrophic pathogens.

c. **" Reduced Oxygen Packaging"** does not include:

- (1) Placing product in a bag and sealing it immediately prior to or after, cooking, cooling or reheating the product as long as the product is:
 - (a) Labeled with the time and date the product is placed in the bag; and
 - (b) Removed from the bag within 48 hours of the time the product is placed in the bag.

93. **"Refuse"** means solid waste not carried by water through the sewage system.
94. **"Re-service"** means the transfer of food that is unused and returned by a consumer after being served or sold and in the possession of the consumer, to another person.
95. **"Restrict"** means to limit the activities of a food employee so that there is no risk of transmitting a disease that is transmissible through food and the food employee does not work with exposed food, clean equipment, utensils, linens, or unwrapped single-service or single-use articles.

96. **“Retail Food Establishment”** means a retail operation that stores, prepares, or packages food for human consumption or serves or otherwise provides food for human consumption to consumers directly or indirectly through a delivery service, whether such food is consumed on or off the premises or whether there is a charge for such food.

“Retail Food Establishment” does not include:

- a. Any private home;
- b. Private boarding houses;
- c. Hospital and health facility patient feeding operations licensed by the Department;
- d. Child care centers and other child care facilities licensed by the Department of Human services;
- e. Hunting camps and other outdoor recreation locations where food is prepared in the field rather than at a fixed base of operation;
- f. Food or beverage wholesale manufacturing, processing, or packaging plants, or portions thereof, that are subject to regulatory controls under state or federal laws or regulations;
- g. Motor vehicles used only for the transport of food;
- h. Establishments preparing and serving only hot coffee, hot tea, instant hot beverages, and nonpotentially hazardous doughnuts or pastries obtained from sources complying with all laws related to food and food labeling;
- i. Establishments that handle only nonpotentially hazardous prepackaged food and operations serving only commercially prepared, prepackaged foods requiring no preparation other than the heating of food within its original container or package;
- j. Farmers markets and roadside markets that offer only uncut fresh fruit and vegetables for sale;
- k. Automated food merchandising enterprises that supply only prepackaged nonpotentially hazardous food or drink or food or drink in bottles, cans, or cartons only, and operations that dispense only chewing gum or salted nuts in their natural protective covering;
- l. The donation, preparation, sale, or service of food by a nonprofit or charitable organization in conjunction with an event or celebration if such donation, preparation, sale, or service of food;
 - (1) Does not exceed the duration of the event or celebration or a maximum of fifty-two days within a calendar year; and
 - (2) Takes place in the county in which such nonprofit or charitable organization resides or is principally located.

97. **“Risk”** means the likelihood that an adverse health effect will occur within a population as a result of a hazard in a food.

98. **“Safe Materials”** means articles manufactured from or composed of materials that may not reasonably be expected to result, directly or indirectly, in their becoming a component or otherwise affecting the characteristic of any food. If materials are food additives or color additives as defined in section 25-5-402(3) or (12), C.R.S., of the “Colorado Pure Food and Drug Law”, as used, they are “safe” only if they are used in conformity with all applicable regulations of the U.S. Food and Drug Administration.
99. **“Sanitization”** means the application of cumulative heat or chemicals on cleaned food-contact surfaces that, when evaluated for efficacy, is sufficient to yield a reduction of 5 logs, which is equal to a 99.999% reduction, of representative disease microorganisms of public health importance.
100. **“Sealed”** means free of cracks or other openings that allow the entry or passage of moisture or debris.
101. **“Self Contained Mobile Retail Food Establishment”** means a licensed mobile retail food establishment that is approved to operate without a commissary, and is not connected to fixed utilities such as water, sewer and electricity, and is required to report to an approved servicing location for sewage disposal and water.
102. **“Service Animal”** means any dog or miniature horse that is individually trained to do work or perform tasks for the benefit of an individual with a disability, including a physical, sensory, psychiatric, intellectual, or other mental disability. Other species of animals, whether wild or domestic, trained or untrained, are not service animals for the purposes of this definition. The work or tasks performed by a service animal must be directly related to the handler's disability. Examples of work or tasks include, but are not limited to, assisting individuals who are blind or have low vision with navigation and other tasks, alerting individuals who are deaf or hard of hearing to the presence of people or sounds, providing non-violent protection or rescue work, pulling a wheelchair, assisting an individual during a seizure, alerting individuals to the presence of allergens, retrieving items such as medicine or the telephone, providing physical support and assistance with balance and stability to individuals with mobility disabilities, and helping persons with psychiatric and neurological disabilities by preventing or interrupting impulsive or destructive behaviors. The crime deterrent effects of an animal's presence and the provision of emotional support, well-being, comfort, or companionship do not constitute work or tasks for the purposes of this definition.
103. **“Sewage”** means liquid waste containing animal or plant matter in suspension or solution and may include liquids containing chemicals in solution.
104. **“Shellstock”** means raw, in-shell, molluscan shellfish.
105. **“Shiga Toxin-Producing *Escherichia coli*”** (STEC) means any *E. coli* capable of producing Shiga toxins (also called verocytotoxins or "Shiga-like" toxins). Examples of serotypes of STEC include both O157 and non-O157 *E. coli*. *Also see* Enterohemorrhagic *Escherichia coli*.
106. **“Shucked Shellfish”** means molluscan shellfish that have one or both shells removed.
107. **“Single-Service Articles”** means cups, containers, lids, closures, plates, knives, forks, spoons, stirrers, paddles, straws, napkins, place mats, doilies, wrapping materials, toothpicks and similar articles intended for one-time, one consumer use and then discarded after use.

108. **“Single-Use Articles”**
- a. **“Single-Use Articles”** means utensils and bulk food containers designed and constructed to be used once and discarded;
 - b. **“Single-Use Articles”** includes items such as wax paper, butcher paper, plastic wrap, formed aluminum food containers, jars, plastic tubs or buckets, bread wrappers, pickle barrels, ketchup bottles, and number 10 cans which do not meet the materials, durability, strength, and cleanability specifications under 4-101, and 4-201 for multiuse utensils.
109. **“Slacking”** means the process of moderating the temperature of a food such as allowing a food to gradually increase from a temperature of -23°C (-10°F) to -4°C (25°F) in preparation for deep-fat frying or to facilitate even heat penetration during the cooking of previously block-frozen food such as shrimp.
110. **“Smooth”** means:
- a. A food-contact surface having a surface free of pits and inclusions with a cleanability equal to or exceeding that of (100 grit) number 3 stainless steel;
 - b. A nonfood-contact surface of equipment having a surface equal to that of commercial grade hot-rolled steel free of visible scale; and
 - c. A floor, wall, or ceiling having an even or level surface with no roughness, projections, perforations, pits, or inclusions that render it difficult to clean.
111. **“Tableware”** means eating, drinking, and serving utensils for table use, such as forks, knives, and spoons; including bowls, cups, serving dishes, tumblers and plates.
112. **“Temperature Measuring Device”** means a thermometer, thermocouple, thermistor, or other device that indicates the temperature of food, air, or water.
113. **“Temporary Event”** means a single community event or celebration that operates for a period of time of not more the fourteen (14) consecutive days and may include town celebrations, fairs, and festivals.
- Temporary events do not include:
- a. Regularly scheduled series of events at venues such as sporting arenas, concert halls, flea markets, or farmers’ markets;
 - b. Events serviced by licensed caterers are not considered temporary events.
 - c. Sporadic promotional events such as grand openings are not considered temporary events.
114. **“Temporary Retail Food Establishment”** means a food establishment that is limited to operating at temporary events only.
115. **“USDA”** means the U.S. Department of Agriculture.
116. **“Utensil”** means a food contact implement or container used in the storage, preparation, transportation, dispensing, sale or service of food, such as kitchenware or tableware that is multiuse, single-service, or single-use.
117. **“Variance”** means a written document issued by the Colorado Department of Public Health and Environment (CDPHE) that authorizes a modification or waiver of one or more requirements of this Code if, in the opinion of CDPHE, a health hazard or nuisance will not result from the modification or waiver.

118. **“Warewashing”** means the cleaning and sanitizing of utensils and food-contact surfaces of equipment.
119. **“Water Activity” (a_w)** see A_w definition in section 1-201(7).
120. **“Whole-Muscle, Intact Beef”** means whole muscle beef that is not injected, mechanically tenderized, reconstructed, or scored and marinated, from which beef steaks may be cut.

CHAPTER 2

MANAGEMENT AND PERSONNEL

2-1 SUPERVISION

2-101 Responsibilities

The operator shall be the person in charge or shall designate a person in charge and shall ensure that a person in charge is present at the retail food establishment during all hours of operation.

*2-102 Demonstration

Based on the risks of foodborne illness inherent to the food operation, during inspections and upon request the person in charge shall demonstrate to the Department knowledge of foodborne disease prevention, application of the Hazard Analysis Critical Control Point principles, and the requirements of these rules and regulations. The person in charge shall demonstrate this knowledge by:

- A. Complying with these rules and regulations by having no violations of critical items during the current inspection; or
- B. Being a certified food protection manager who has shown proficiency of required information through passing a test that is part of an accredited program; or
- C. Responding correctly to the inspector's questions as they relate to the specific food operation. The areas of knowledge include:
 1. Describing the relationship between the prevention of foodborne disease and the personal hygiene of a food employee;
 2. Explaining the responsibility of the person in charge for preventing the transmission of foodborne disease by a food employee who has a disease or medical condition that may cause foodborne disease;
 3. Describing the symptoms associated with the diseases that are transmissible through food;
 4. Explaining the hazards involved in the consumption of raw or undercooked meat, poultry, eggs and fish;
 5. Stating the required temperatures and times for the safe cooking, refrigerated storage, hot holding, cooling, and reheating of potentially hazardous food (time/temperature control for safety food);
 6. Describing the relationship between the prevention of foodborne illness and the management and control of the following:
 - a. Cross contamination,
 - b. Hand contact with ready-to-eat foods,
 - c. Handwashing, and
 - d. Maintaining the food establishment in a clean condition and in good repair;

7. Explaining the relationship between food safety and providing equipment that is:
 - a. Sufficient in number and capacity, and
 - b. Properly designed, constructed, located, installed, operated, maintained, and cleaned;
8. Explaining correct procedures for cleaning and sanitizing utensils and food-contact surfaces of equipment;
9. Identifying the source of water used and measures taken to ensure that it remains protected from contamination such as providing protection from backflow and precluding the creation of cross connections;
10. Identifying poisonous or toxic materials in the food establishment and the procedures necessary to ensure that they are safely stored, dispensed, used, and disposed of according to law;
11. Explaining the relationship between maintaining the time and temperature of potentially hazardous food (time/temperature control for safety food);
12. Identifying critical control points in the operation from purchasing through sale or service that when not controlled may contribute to the transmission of foodborne illness and explaining steps taken to ensure that the points are controlled in accordance with the requirements of these rules and regulations.
13. Explaining the details of how the establishment, person in charge and food employees complies with conditions of any approved variance or any Department approved time as a public health control plan for potentially hazardous food (time/temperature control for safety food) and with any HACCP plan required by the Department.
14. Explaining the responsibilities, rights, and authorities assigned by these rules and regulations to the:
 - a. Food employee
 - b. Conditional employee
 - c. Person in charge, and
 - d. Department
15. Explaining how the person in charge, food employees, and conditional employees comply with reporting responsibilities and exclusion or restriction of food employees.
16. Describing foods identified as major food allergens and the symptoms that a major food allergen could cause in a sensitive individual who has an allergic reaction.

***2-103 Person in Charge**

The person in charge shall educate and monitor employees to ensure that:

- A. Employees are effectively cleaning their hands, by routinely monitoring the employees' handwashing;
- B. Employees are visibly observing foods as they are received to determine that they are from approved sources, delivered at the required temperatures, protected from

- contamination, unadulterated, and accurately presented, by routinely monitoring the employees' observations and periodically evaluating foods upon their receipt;
- C. Employees are properly cooking potentially hazardous food (time/temperature control for safety food), being particularly careful in cooking those foods known to cause severe foodborne illness and death, such as eggs and comminuted meats, through daily oversight of the employees' routine monitoring of the cooking temperatures using appropriate temperature measuring devices properly scaled and calibrated as specified in section 4-401 of these rules and regulations;
 - D. Employees are using proper methods to rapidly cool potentially hazardous foods (time/temperature control for safety foods) that are not held hot or are not for consumption within 4 hours, through daily oversight of the employees' routine monitoring of food temperatures during cooling;
 - E. Employees are properly sanitizing cleaned multiuse equipment and utensils before they are reused, through routine monitoring of solution temperature and exposure time for hot water sanitizing, and chemical concentration, pH, temperature, and exposure time for chemical sanitizing;
 - F. Consumers are notified that clean tableware is to be used when they return to self-service areas such as salad bars and buffets as specified in section 3-411(A);
 - G. Employees prevent bare hand contact with ready-to-eat food by properly using suitable utensils such as deli tissue, spatulas, tongs, single-use gloves, or dispensing equipment;
 - H. Employees are properly trained in food safety as it relates to their assigned duties;
 - I. Food employees and conditional employees are informed of their responsibilities to report their illnesses and infections transmissible through food to the person in charge, so that the person in charge may exclude or restrict any employees who are ill, have a boil or wound, and when to notify the department of illnesses;
 - J. Employees and other persons such as delivery and maintenance persons and pesticide applicators entering the food preparation food storage, and warewashing areas comply with this code; and
 - K. Consumers who order raw or partially cooked ready-to-eat foods of animal origin are informed as specified in section 3-801 of these rules and regulations that the food is not cooked sufficiently to ensure its safety.

2-2 EMPLOYEE HEALTH

***2-201 Responsibility of Licensee, Person in Charge, and Employees**

- A. The licensee shall require food employees and conditional employees to report to the person in charge information about their health and activities as they relate to diseases that are transmissible through food. A food employee or conditional employee shall report pertinent information in a manner that allows the person in charge to reduce the risk of foodborne disease transmission, if the food employee or conditional employee:
 - 1. Has any of the following symptoms:
 - a. Vomiting;
 - b. Diarrhea;
 - c. Jaundice;

- d. Sore throat with fever; or
 - e. A lesion containing pus such as a boil or infected wound that is open and/or draining and is:
 - (1) On the hands or wrists, unless an impermeable cover such as a finger cot or stall protects the lesion and a single-use glove is worn over the impermeable cover;
 - (2) On exposed portions of the arms, unless the lesion is protected by an impermeable cover; or
 - (3) On other parts of the body, unless the lesion is covered by a dry, durable, tight-fitting bandage.
 - 2. Has an illness diagnosed by a health practitioner due to:
 - a. Norovirus;
 - b. Hepatitis A virus;
 - c. Shigella spp.;
 - d. Enterohemorrhagic or Shiga Toxin-Producing Escherichia coli;
 - e. Salmonella Typhi; or
 - f. Other enteric bacterial pathogen such as Salmonella or Campylobacter.
 - 3. Had a previous illness, diagnosed by a health practitioner, within the past three (3) months due to Salmonella Typhi, as determined by a health practitioner.
- B. The person in charge shall notify the Department when a food employee is:
- 1. Jaundiced; or
 - 2. Diagnosed with an illness due to a pathogen as specified in Subparagraphs (A)(2) and (A)(3) of this section.
- C. The person in charge shall ensure that a conditional employee who exhibits or reports a symptom, or who reports a diagnosed illness as specified in Subparagraphs (A)(1)-(3) of this section, is prohibited from becoming a food employee until the conditional employee meets the criteria for the specific symptoms or diagnosed illness as specified section 2-203.
- D. The person in charge shall ensure that a food employee who exhibits or reports a symptom, or who reports a diagnosed illness as specified in subparagraphs (A)(1)-(3) of this section is:
- 1. Excluded as specified in 2-202 (A)-(D)(1), (E)(1), (F), (G)(1), and in compliance with the provisions specified under 2-203(A) - (F); or
 - 2. Restricted as specified in subparagraphs 2-202 (D)(2), (E)(2), (F), (G)(2), (H), and in compliance with the provisions specified under 2-203 (A)-(F).
- E. A food employee or conditional employee shall report to the person in charge the information as specified in (A) of this section.
- F. A food employee shall:
- 1. Comply with an exclusion as specified in 2-202 (A)-(D)(1), (E)(1), (F), (G)(1); or

2. Comply with a restriction as specified in subparagraphs 2-202 (D)(2), (E)(2), (F), (G)(2), (H), and in compliance with the provisions specified under 2-203 (A)-(F).

***2-202 Exclusions and Restrictions**

The person in charge shall exclude or restrict a food employee from a food establishment in accordance with the following:

- A. Except when the symptom is from a noninfectious condition, exclude a food employee if the food employee is:
 1. Symptomatic with vomiting or diarrhea; or
 2. Symptomatic with vomiting or diarrhea and diagnosed with an infection from Norovirus, Shigella spp., or Enterohemorrhagic or Shiga toxin-producing E. coli.
- B. Exclude a food employee who is:
 1. Jaundiced and the onset of jaundice occurred within the last seven (7) calendar days, unless the food employee provides to the person in charge written medical documentation from a health practitioner specifying that the jaundice is not caused by hepatitis A virus or other fecal-orally transmitted infection;
 2. Diagnosed with an infection from hepatitis A virus within fourteen (14) calendar days from the onset of any illness symptoms, or within seven (7) calendar days of the onset of jaundice; or
 3. Diagnosed with an infection from hepatitis A virus without developing symptoms.
- C. Exclude a food employee who is diagnosed with an infection from Salmonella Typhi, or reports a previous infection with Salmonella Typhi within the past three (3) months as specified under Subparagraph 2-201(A)(3).
- D. If a food employee is diagnosed with an infection from Shigella spp. and is asymptomatic:
 1. Exclude the food employee who works in a food establishment serving a highly susceptible population; or
 2. Restrict the food employee who works in a food establishment not serving a highly susceptible population.
- E. If a food employee is diagnosed with an infection from Enterohemorrhagic or Shiga toxin-producing E. coli, and is asymptomatic:
 1. Exclude the food employee who works in a food establishment serving a highly susceptible population; or
 2. Restrict the food employee who works in a food establishment not serving a highly susceptible population.
- F. If a food employee is diagnosed with another bacterial enteric pathogen and is asymptomatic consult with the Department to determine the need for exclusion or restriction.
- G. If a food employee is ill with symptoms of acute onset of sore throat with fever:

1. Exclude the food employee who works in a food establishment serving a highly susceptible population; or
 2. Restrict the food employee who works in a food establishment not serving a highly susceptible population.
- H. If a food employee is infected with a skin lesion containing pus such as a boil or infected wound that is open or draining and not properly covered as specified in section 2-201(A)(1)(e), restrict the food employee.

***2-203 Removal, Adjustment, or Retention of Exclusions and Restrictions**

The person in charge shall adhere to the following conditions when removing, adjusting, or retaining the exclusion or restriction of a food employee:

- A. Reinstate a food employee who was excluded as specified in section 2-202(A)(1) if the employee:
1. Is asymptomatic for at least 24 hours; or
 2. Provides to the person in charge written medical documentation from a health practitioner that states the symptom is from a noninfectious condition.
 3. If a food employee was diagnosed with an infection from Norovirus and excluded as specified in section 2-202(A)(2) , the food employee should not be reinstated until the employee has been asymptomatic for at least 48 hours and the person in charge obtains approval from the Department.
 4. If a food employee was diagnosed with an infection from Shigella spp. and excluded as specified in section 2-202(A)(2) , the food employee should not be reinstated until the employee has met parameters listed in the Colorado Communicable Disease Manual and the person in charge obtains approval from the Department.
 5. If a food employee was diagnosed with an infection from Enterohemorrhagic or Shiga toxin-producing Escherichia coli and excluded as specified in section 2-202(A)(2), the food employee should not be reinstated until the employee has met parameters listed in the Colorado Communicable Disease Manual and the person in charge obtains approval from the Department.
- B. Reinstate a food employee who was excluded as specified under Subparagraphs 2-202(B) if the employee has met parameters listed in the Colorado Communicable Disease Manual and the person in charge obtains approval from the Department.
- C. Reinstate a food employee who was excluded as specified in 2-202(C). If the employee has met parameters listed in the Colorado Communicable Disease Manual and the person in charge obtains approval from the Department.
- D. Reinstate a food employee who was restricted as specified in 2-202(H) if the skin, infected wound, cut, or pustular boil is properly covered with one of the following:
1. An impermeable cover such as a finger cot or stall and a single-use glove over the impermeable cover if the infected wound or pustular boil is on the hand, finger, or wrist;
 2. An impermeable cover on the arm if the infected wound or pustular boil is on the arm; or

3. A dry, durable, tight-fitting bandage if the infected wound or pustular boil is on another part of the body.
- E. Reinstatement a food employee who was excluded as specified under subparagraphs 2-202(D)(1) or who was restricted under Subparagraph 2-202(D)(2). The food employee should not be reinstated until the employee has been asymptomatic for at least 48 hours and the person in charge obtains approval from the Department.
- F. Reinstatement a food employee who was excluded or restricted as specified in Subparagraphs 2-202(H)(1) or (2) if the food employee provides to the person in charge written medical documentation from a health practitioner stating that the food employee meets one of the following conditions:
1. Has received antibiotic therapy for Streptococcus pyogenes infection for more than 24 hours;
 2. Has at least one negative throat specimen culture for Streptococcus pyogenes infection; or
 3. Is otherwise determined by a health practitioner to be free of a Streptococcus pyogenes infection.

2-204 Discharges from the Eyes, Nose and Mouth

Food employees experiencing persistent sneezing, coughing, or a runny nose that causes discharges from the eyes, nose or mouth may not work with exposed food, clean equipment, utensils, and linens, or unwrapped single-service or single-use articles.

2-3 AUTHORIZED PERSONNEL

Only persons necessary to the operation and maintenance of the retail food establishment shall be allowed in food preparation, food storage, food equipment storage, and warewashing areas.

2-4 PERSONAL CLEANLINESS

***2-401** Food employees shall keep their hands and exposed portions of their arms clean.

***2-402 Cleaning Procedure**

- A. Food employees shall clean their hands and exposed portions of their arms including surrogate prosthetic devices for hands or arms with soap and water for at least 20 seconds and shall use the following cleaning procedure:
1. Vigorous friction on the surfaces of the lathered fingers, finger tips, areas between the fingers, hands and arms for at least 15 seconds, followed by;
 2. Thorough rinsing under clean, running warm water; and
 3. Immediately follow the cleaning procedure with thorough drying of cleaned hands and arms with disposable or single use towels or a mechanical hand drying device.
- B. Food employees shall pay particular attention to removing soil underneath the fingernails during the cleaning procedure.

- C. If approved and capable of removing the types of soils encountered in the food operations involved, an automatic handwashing facility installed and operated as per section 5-208(I) may be used by food employees to clean their hands.

***2-403 When to Wash**

Food employees shall clean their hands and exposed portions of their arms immediately before engaging in food preparation including working with exposed food, clean equipment and utensils, and unwrapped single-service and single-use articles and:

- A. Before leaving the restroom, and after returning to food and beverage preparation, food storage, equipment storage and warewashing areas from using the restroom;
- B. After coughing, sneezing, using a handkerchief or disposable tissue, using tobacco, eating, or drinking;
- C. When switching between working with raw foods of animal origin and working with ready-to-eat foods;
- D. After touching bare human body parts other than clean hands and clean, exposed portions of arms;
- E. During food preparation, as often as necessary to remove soil and contamination and to prevent cross-contamination when changing tasks;
- F. Before handling or putting on single-use gloves for working with food, and between removing soiled gloves and putting on clean gloves;
- G. After handling soiled equipment or utensils;
- H. After caring for or handling any animals;
- I. After engaging in any activities that contaminate the hands; and
- J. After handling fish in aquariums, shellfish, or crustacea in display tanks.

***2-404 Hand Antiseptics**

Hand antiseptics may be used in addition to but not in place of proper handwashing.

***2-405 Where to Wash**

Food employees shall clean their hands in a handsink or approved automatic handwashing facility and may not clean their hands in a sink used for food preparation or warewashing, in a dump sink, or in a utility sink or a curbed cleaning facility used for the disposal of mop water and similar liquid waste.

***2-406 Fingernail Care**

- A. Food employees shall keep their fingernails clean, trimmed, filed and maintained so the edges and surfaces are cleanable and not rough.
- B. Unless wearing intact gloves in good repair, a food employee may not wear fingernail polish or artificial fingernails when working with exposed food.

2-407 Clothing

Employees shall wear clean outer clothing to prevent cross-contamination.

2-408 Jewelry

Except for a plain ring such as a wedding band, while preparing food, food employees may not wear jewelry, watches, or medical information bracelets on their wrists and hands or any other area of the arm that may interfere with proper handwashing or result in contamination of food.

2-5 HYGIENIC PRACTICES

***2-501 General**

Employees shall maintain a high degree of personal cleanliness and shall conform to good hygienic practices during all working periods. Proper hygienic practices must be followed by retail food employees in performing assigned duties to ensure the safety of the food, prevent the introduction of foreign objects into the food, and minimize the possibility of transmitting disease through food.

***2-502 Eating, Drinking, or Using Tobacco**

- A. Except as specified in paragraph B, employees shall consume food, drink or use tobacco only in designated areas. Such designated areas must be located so that eating or tobacco use by an employee does not result in contamination of food, equipment, utensils, or other items needing protection.
- B. An employee may drink from a closed beverage container such as pop top sport bottles when teeth or mouth are used to open the top, cups with a lid and a straw, and cups with snap-on lids with a hole in the top if:
 - 1. The container is clean;
 - 2. It does not contaminate the employee's hands; and
 - 3. It is stored to prevent the contamination of exposed food, clean equipment, utensils, linens, unwrapped single-service and single-use articles.

2-503 Hair Restraints

- A. Except as provided under paragraph B of this section, food employees engaged in food preparation shall wear hair restraints, such as hats, hair coverings, hair or beard nets, or other effective means, to effectively keep hair from contacting exposed food, clean equipment, utensils, and linens, and unwrapped single-service or single-use articles.
- B. This section does not apply to employees such as counter staff who serve only beverages and wrapped or packaged foods, or hosts, bartenders, and wait staff who present a minimal risk of contaminating exposed foods, clean equipment, utensils, and linens, and unwrapped single-service and single-use articles.

CHAPTER 3

FOOD

3-1 CHARACTERISTICS

*3-101 General

Food shall be safe and unadulterated. Food shall be in sound condition, free from spoilage or contamination and shall be safe for human consumption. Food shall not contain unsafe or unapproved food or color additives per 21 CFR 170-186. Food shall be obtained from approved sources that comply with the applicable laws relating to food and food labeling. Food prepared or stored in a private home shall not be used, distributed, or offered for sale.

3-2 SOURCES AND SPECIFICATIONS

3-201 Shellfish and Fish

*A. Molluscan Shellfish

Molluscan Shellfish shall be obtained from sources according to law and the requirements specified in the U.S. Department of Health and Human Services, Public Health Service, Food and Drug Administration, National Shellfish Sanitation Program Guide for the Control of Molluscan Shellfish.

B. Maintaining Shellstock Identification

*1. Fresh and frozen shucked molluscan shellfish (oysters, clams, mussels or scallops) shall be received and/or repacked in non-returnable packages identified with the name and address of the original shellstock processor, shucker-packer, or repacker, and the state shellstock certification number issued according to law. Shucked molluscan shellfish shall be kept in the container in which they were received until used or sold.

Each original container of unshucked molluscan shellfish shall be identified by an attached tag, to be retained for a period of 90 days after the container is emptied. The tag shall be marked with the empty date and, the name and address of the original shellfish processor, the kind and quantity of shellfish, and the certification number issued by the State or foreign shellfish control agency, where applicable. Tags shall be stored in chronological order from the empty date.

Shellstock from one tagged or labeled container shall not be commingled with shellstock from another container before being ordered by the consumer.

*2. When received by a food establishment, unshucked shellstock shall be reasonably free of mud, dead shellfish, and shellfish with broken shells. Dead shellfish or shellstock with badly broken shells shall be discarded.

*C. Molluscan shellfish that are recreationally caught may not be received for sale or service.

*D. Fish that are received for sale or service shall be:

1. Commercially and legally caught or harvested; or
2. Approved for sale or service.

- *E. Raw shucked shellfish shall be obtained in nonreturnable packages which bear a legible label that identifies the:
 1. Name, address, and certification number of the shucker, packer or repacker of the molluscan shellfish; and
 2. The "sell by" or "best if used by" date for packages with a capacity of less than 1.89 L (one-half gallon) or the date shucked for packages with a capacity of 1.89 L (one-half gallon) or more.
- F. Molluscan Shellfish, Original Container.
 1. Except as specified in (G) - (H) of this section, molluscan shellfish may not be removed from the container in which they are received other than immediately before sale or preparation for service.
- G. For display purposes, shellstock may be removed from the container in which they are received, displayed on drained ice, or held in a display container, and a quantity specified by a consumer may be removed from the display or display container and provided to the consumer if:
 1. The source of the shellstock on display is identified as specified in section 3-201(A); and
 2. The shellstock are protected from contamination.
- H. Shucked shellfish may be removed from the container in which they were received and held in a display container from which individual servings are dispensed upon a consumer's request if:
 1. The labeling information for the shellfish on display as specified in section 3-201(E) is retained and correlated to the date when, or dates during which, the shellfish are sold or served; and
 2. The shellfish are protected from contamination.

3-202 Parasite Destruction

- *A. Except as specified in (B) of this section, before service or sale in ready-to-eat form, raw, raw-marinated, partially cooked, or marinated-partially cooked fish shall be:
 1. Frozen and stored at a temperature of -4°F (-20°C) or below for a minimum of 168 hours (7 days) in a freezer;
 2. Frozen at -31°F (-35°C) or below until solid and stored at -31°F (-35°C) or below for a minimum of 15 hours; or
 3. Frozen at -31°F (-35°C) or below until solid and stored at -4°F (-20°C) or below for a minimum of 24 hours.

The freezing temperature and time to which the fish are subjected shall be recorded, retained and made readily available upon request at the food establishment for 90 calendar days after the time of service or sale of the fish.

If the fish are frozen by the retail food establishment and/or supplier, a written agreement or statement from the supplier stipulating that the fish supplied are frozen to the proper temperature and for a time specified in this section may substitute for the records required.

- B. Paragraph (A) of this section does not apply to:
1. Molluscan shellfish;
 2. Tuna of the species *Thunnus alalunga*, *Thunnus albacares* (Yellowfin tuna), *Thunnus atlanticus*, *Thunnus maccoyii* (Bluefin tuna, Southern), *Thunnus obesus* (Bigeye tuna), or *Thunnus thynnus* (Bluefin tuna, Northern); or
 3. Aquacultured fish, such as salmon, that:
 - a. If raised in open water, are raised in net-pens, or
 - b. Are raised in land-based operations such as ponds or tanks, and
 - c. Are fed formulated feed, such as pellets, that contains no live parasites infective to the aquacultured fish.
 - d. If raw, raw-marinated, partially cooked, or marinated-partially cooked fish are served or sold in ready-to-eat form, and the fish are raised and fed as specified in section 3-202(B)(3)(a)-(c), a written agreement or statement from the supplier or aquaculturist stipulating that the fish were raised and fed as specified in section 3-202(B)(3)(a)-(c) shall be obtained by the person in charge and retained in the records of the food establishment for 90 calendar days beyond the time of service or sale of the fish.
 4. Fish eggs that have been removed from the skein and rinsed.

3-3 SOURCES AND SPECIFICATIONS

***3-301 Package Integrity**

Food packages shall be in good condition and protect the integrity of the contents so that the food is not exposed to adulteration or potential contaminants.

***3-302 Hermetically Sealed Food**

- A. The use, distribution, or sale of food from hermetically sealed containers that was not prepared in an approved food processing establishment or retail food establishment that is approved for this type of processing, is prohibited.
- B. Hermetically sealed packages shall be handled so as to maintain product and container integrity. The “Guide to Can Defects and Basic Components of Double Seam Containers”, November 2011, published by the Association of Food and Drug Officials, shall be used to determine container integrity. Food items that are spoiled or that are in damaged containers that may affect the product and those food items that have been returned to, or are being detained by, the retail food establishment because of spoilage, container damage, or other public health considerations shall be segregated and held in designated areas pending proper disposition unless disposed of under the supervision of the Department.

***3-303 Dry Milk and Dry Milk Products**

Dry milk and milk products used, served or offered for sale shall be made from pasteurized milk and milk products.

***3-304 Reconstitution of Dry Milk, Dry Milk Products and Non-Dairy Products**

Dry milk, dry milk products and non-dairy creaming, whitening, or whipping agents may be reconstituted with potable water on the premises only when they will be stored in sanitized, covered containers and cooled to 41°F (7°C) or below within four hours after preparation.

Reconstituted dry milk cannot be substituted for use as a Grade A fluid milk product in its final form (e.g. for drinking, over cereal, etc.).

***3-305 Fluid Milk, Fluid Milk Products, and Frozen Dessert Mix**

- A. Fluid milk and fluid milk products used, served or offered for sale shall comply with the Colorado Grade A Pasteurized Fluid Milk and Milk Products Regulation.
- B. Only pasteurized mix from an approved licensed dairy plant may be mixed and/or frozen by a counter freezer.
- C. Raw milk supplied to and held by retail food establishments for distribution to shareholders shall meet the requirements of section 25-5.5-117 et. seq., C.R.S.
 - 1. Only farms or dairies that are properly registered with the Department may distribute raw milk.
 - 2. Only an owner or shareholder of a cow, goat or dairy herd may distribute raw milk from a retail food establishment. Distribution of raw milk by management or employees of a retail food establishment that are not owners or shareholder of a cow, goat or dairy herd is prohibited.
 - 3. Only an owner or shareholder of a cow, goat or dairy herd shall receive raw milk from the farm or dairy where the cow or goat is located or from a shareholder of the same cow, goat or dairy herd.
 - 4. Containers used to hold raw milk shall have a prominent warning statement that the milk is not pasteurized, is delivered to the shareholder with the milk or is displayed on a label affixed to the milk container.
 - 5. Storage of raw milk with other food is prohibited. Raw milk must be stored in a separate refrigerator or cooler that is used only for raw milk and must be stored in a manner where it cannot be mistaken for pasteurized milk. Display or access of raw milk to the public is prohibited.

***3-306 Wild Mushrooms**

- A. Except as specified in paragraph B of this section, mushroom species picked in the wild shall be obtained from sources where each mushroom is individually inspected and found to be safe by a mushroom identification expert approved by the Department. To be approved by the department an individual must:
 - 1. Identify which county(ies) and retail food establishments they will supply wild mushrooms;
 - 2. Provide the genus and species of the wild mushrooms that will be supplied;
 - 3. Provide written verification detailing their qualifications that demonstrate their ability to identify and pick wild mushrooms that are safe for human consumption such as educational degrees, years of experience, membership to any professional organizations;

4. Provide a written letter of reference from a separate individual who can verify the picker has the expertise. The person supplying the letter of reference must be a recognized mycologist who can attest the picker has the ability to identify the genus and species of wild mushrooms they intend to pick;
 5. Maintain records for at least two (2) years identifying the buyers, the type of mushroom(s) received and the quantity received, and;
 6. Supply an invoice to the buyer with each shipment that identifies:
 - a. The variety of mushroom by common name and genus and species;
 - b. The quantity;
 - c. The suppliers name, address, and date of packing.
- B. This section does not apply to:
1. Cultivated wild mushroom species that are grown, harvested, and processed in an operation that is regulated by the regulatory agency that has jurisdiction over the operation; or
 2. Wild mushroom species if they are in packaged form and are the product of a food processing plant that is regulated by the food regulatory agency that has jurisdiction over the plant.

***3-307 Meat, Poultry, Game Animals and Exotic Species**

Game animals and exotic species may be received for sale or service provided they are slaughtered and processed according to laws governing meat and poultry as determined by the agency that has animal health jurisdiction and the agency that conducts the inspection program.

- A. Meat and poultry are required to come from a USDA FSIS inspected facility.
 1. Meats listed in the Federal Meat Inspection Act that require mandatory USDA inspection include cattle, swine, sheep, goats, horse, mule, other equine, and any others as determined by the USDA.
 2. Poultry listed in the Poultry Products Inspection Act that require Mandatory USDA Inspection include chicken, geese, duck, turkey, guineas, emu, ratite, ostrich, squab (pigeon), and any others as determined by the USDA.
- B. Game animals indigenous to North America such as reindeer, elk, deer, antelope, water buffalo, bison, rabbit, squirrel, opossum, raccoon, nutria, or muskrat, and any others as determined by the USDA shall go through the USDA Voluntary Meat Inspection Program in order to be considered an approved source.
- C. Poultry products that are game animals are required to be inspected under the USDA Voluntary Poultry Inspection Program. Species include Quail, pheasant, dove, other game birds and any others as determined by the USDA.
- D. Any other game animal that is obtained from a retail food establishment would fall under FDA inspection authority. This would include rattlesnake, bear, alligator, and any others as determined by the USDA.
- E. Game animals obtained from States that have contracts with the FDA or USDA to conduct inspections of game animal food processing establishments are recognized by the Department as being an approved regulatory authority and food products received from these states are considered an approved source.

For additional guidance, refer to the Colorado Department of Public Health and Environment issued interpretative memo titled “Determining Approved Source for Meat, Poultry, Game Animals, and Exotic Animal Species.”

***3-308 Eggs**

- A. Only clean intact, approved shell eggs meeting applicable grade standards or pasteurized shell, liquid, frozen or dry eggs, or pasteurized dry egg products shall be used or offered for sale.
- B. The egg carton must be new, clean and properly labeled to include the supplier’s name and address, egg grade, size and pack date. *FDA Safe Handling Instructions* on the carton are required.
- C. Eggs can be offered for sale loose or in a basket, but must have an accompanying card or sign that contains the required labeling information including the wash and process date versus a pack date as indicated on a carton.
- D. Pooling of raw shell eggs is allowed only if the eggs are 41°F (5°C) or below when they are cracked and maintained at 41°F (5°C) or below until cooked.

3-309 Ice

- *A. Only ice which has been manufactured from drinking water and handled in a sanitary manner shall be used or offered for sale. Ice offered for sale shall be packaged and properly labeled.
- B. Ice for human consumption shall be drained.

***3-310 Ice Used as Exterior Coolant, Prohibited as Ingredient**

Ice used as a cooling medium for food storage, beverage containers, food containers or food utensils shall not be used or sold for human consumption.

3-311 Storage or Display of Food in Contact With Water or Ice

- A. Packaged food may be stored in direct contact with drinking water if the packaging, wrapping, or container is not subject to entry of water.
- B. Except as specified in C and D of this section, unpackaged food may not be stored in direct contact with undrained ice.
- C. Whole raw fruits and whole or cut raw vegetables, such as celery or carrot sticks or cut potatoes; and tofu may be immersed in ice made with drinking water.
- D. Raw chicken and raw fish that are received immersed in ice made with drinking water in shipping containers may remain in that condition while in storage awaiting preparation, display, service, or sale.

***3-312 Juice**

- A. Pre-packaged juice shall be obtained pasteurized; in a sterile shelf-stable form in a hermetically sealed container; or otherwise treated under an approved HACCP plan as specified in 21 CFR section 120.24, (2003) to attain a 5-log reduction of the most resistant microorganism of public health significance.

- B. Juice packaged in a retail establishment and sold exclusively and directly to its consumers does not have to be processed in conformance with an approved HACCP plan, but if packaged shall bear the phrase: **“WARNING: This product has not been pasteurized and, therefore, may contain harmful bacteria that can cause serious illness in children, the elderly, and persons with weakened immune systems”** and meet the requirements of the Federal Fair Packaging and Labeling Act.

***3-313 Whole-Muscle, Intact Beef Steaks**

Whole-muscle, intact beef steaks that are intended for consumption in an undercooked form without a consumer advisory as specified in section 3-801 shall be:

- A. Obtained from a food processing plant that, upon requested by the purchaser, packages the steaks and labels them, to indicate that the steaks meet the definition of whole-muscle, intact beef, or
- B. Deemed acceptable by the Department based on other evidence, such as written buyer specifications or invoices, that indicates that the steaks meet the definition of whole-muscle, intact beef; and
- C. If individually cut in a food establishment:
 - 1. Cut from a whole-muscle intact beef that is labeled by a food processing plant as specified in part (A) of this section or identified as specified in part (B) of this section;
 - 2. Prepared so they remain intact; and
 - 3. If packaged for undercooking in a food establishment, labeled as specified in part (A) of this section or as identified in part (B) of this section.

3-4 PROTECTION FROM CONTAMINATION AFTER RECEIVING

***3-401 Preventing Contamination from Hands**

- A. Food employees shall wash their hands as specified in section 2-402 of these rules and regulations.
- B. Food employees shall minimize bare hand and arm contact with exposed food that is not in a ready-to-eat form.
- C. Except when washing fruits and vegetables as specified in section 3-408(A) of these rules and regulations or except as specified in (D) of this section, food employees may not contact exposed, ready-to-eat food including fruits and vegetables with their bare hands and shall use suitable utensils such as deli tissue, spatulas, tongs, single-use gloves, or dispensing equipment.
- D. Food employees not serving a highly susceptible population may contact exposed, ready-to-eat food with their bare hands if:
 - 1. Written procedures are maintained in the food establishment and made available to the Department upon request that include:
 - a. A listing of the ready-to-eat food categories that are touched by bare hands;

- b. Handwashing facilities are, equipped, maintained, are easily accessible and in close proximity to the work station(s) where the bare hand contact procedure is conducted as specified in section 5-208 (B) – (J) of these rules and regulations;
 - c. A written employee health policy that details how the food establishment will comply with sections 2-201, 2-202, 2-203, and 2-204 of these rules and regulations, including health conditions upon which the food employee will not be allowed to work and acknowledgement of their responsibilities as specified in sections 2-201 and 2-202;
 - d. An employee training program that documents completion of the following training areas:
 - (1) The risks of contacting the ready-to-eat foods with bare hands;
 - (2) Proper handwashing as specified in section 2-401 and 2-402;
 - (3) When to wash their hands as specified in section 2-403;
 - (4) Where to wash their hands as specified in section 2-405;
 - (5) Proper fingernail maintenance as specified in section 2-406 (A);
 - (6) Prohibition of jewelry as specified in section 2-408; and
 - (7) Good hygienic practices as related to section 2-501 and section 2-502.
2. Hands are washed prior to food preparation and as necessary to prevent cross contamination as specified in section 2-401, 2-402, 2-403 and 2-405 by food employees during all hours of operation when the specific ready-to-eat foods are prepared.
3. In addition to the requirements specified in section 2-403 “When to Wash”, food employees contacting ready-to-eat foods with bare hands utilize two or more of the following control measures to provide additional safeguards to hazards associated with bare hand contact:
- a. Double handwashing;
 - b. Nail brushes;
 - c. A hand antiseptic after handwashing as specified in section 2-404;
 - d. Incentive programs that encourage food employees not to work when they are ill with a communicable disease that can be transmitted by foods as specified in section 2-201; or
 - e. Other control measures approved by the Department.
4. Corrective actions are immediately taken when subparagraphs D (1) - (3) of this section are not followed. Accompanying monitoring, corrective actions, and appropriate documentation are required.
- E. If a food establishment is found to be in non-compliance with the requirements listed in subparagraphs D (1) - (4) and a civil penalty has been issued in accordance with C.R.S., §25-4-1611, as a result of this non-compliance, or if a confirmed foodborne illness is associated with bare hand contact and ill employees, the Department may suspend or

revoke the food establishment's allowance for food employees to contact ready-to-eat foods with their bare hands.

- F. If the allowance for a food establishment to contact ready-to-eat foods with bare hands is voluntarily discontinued by the food establishment, suspended or revoked as provided for in subparagraph E, a food establishment may not reinstate bare hand contact with ready-to-eat foods without prior written approval from the Department.

3-402 Glove Use

- *A. If used, single-use gloves shall be used for only one task, such as working with ready-to-eat food, or with raw animal food. Single-use gloves shall be used for no other purpose, and discarded when damaged, when interruptions occur in the operation, or when the task is completed.
- B. Except as specified in (C) slash-resistant gloves that are used to protect the hands during operations requiring cutting shall be used in direct contact only with food that is subsequently cooked as specified in part 3-5 such as frozen food or a primal cut of meat.
- C. Slash-resistant gloves may be used with ready-to-eat food that will not be subsequently cooked if the slash-resistant gloves have a smooth, durable, and nonabsorbent outer surface; or if the slash-resistant gloves are covered with a smooth, durable, nonabsorbent glove, or a single-use glove.
- D. Cloth gloves may not be used in direct contact with food unless the food is subsequently cooked as required under section 3-5 such as frozen food or a primal cut of meat.

***3-403 Preventing Contamination When Tasting**

A food employee may not use a utensil more than once to taste food that is to be sold or served.

***3-404 General**

At all times, including while being stored, prepared, displayed, dispensed, packaged, or transported, food shall be protected from cross-contamination between foods and from potential contamination by insects, insecticides, rodents, rodenticides, other toxins, probe-type price tags or probe-type identification tags, unclean equipment and utensils, unnecessary handling, flooding, draining, overhead leakage or condensation, or other agents of public health significance. Hanging primal cuts and quarters or sides of meat, and uncut raw fruits and vegetables do not need to be over wrapped or covered. Foods in original individual packages must be over wrapped or covered if the package has been torn or broken. During transportation, including transportation to another location for service or catering operations, food shall meet the requirements of these rules and regulations relating to food protection, food storage and temperature maintenance of potentially hazardous foods (time/temperature control for safety foods).

***3-405 Cross-Contamination Control**

Each time there is a change in processing between raw beef, raw pork, other raw meats, raw poultry, raw fish and molluscan shellfish or from raw to ready-to-eat foods, food-contact surfaces and utensils shall be cleaned and sanitized as specified in 4-403 and 4-404. Salads and other ready-to-eat foods may also be prepared simultaneously in areas that are separated by a barrier or open space from areas used for processing potentially hazardous raw products.

3-406 Packaged and Unpackaged Food - Separation, Packaging, and Segregation

- A. Food shall be protected from cross contamination by separating raw animal foods during storage, preparation, holding, and display from:
 - *1. Raw ready-to-eat food including other raw animal food such as fish for sushi or molluscan shellfish, or other raw ready-to-eat food such as fruits and vegetables; and
 - *2. Cooked ready-to-eat food;
- B. Frozen, commercially processed and packaged raw animal food may be stored or displayed with or above frozen, commercially processed and packaged, ready-to-eat food.

***3-407 Pasteurized Eggs, Substitute for Shell Eggs for Certain Recipes**

Pasteurized eggs or egg products shall be substituted for raw eggs in the preparation of foods such as Caesar salad, hollandaise or Béarnaise sauce, mayonnaise, meringue, eggnog, ice cream, and egg-fortified beverages that are not cooked as specified in section 3-502 (D). This section does not apply if there is a Consumer Advisory in place as specified in Section 3-801 excepts as prohibited by Section 3-702(C).

3-408 Washing Fruits and Vegetables/Additives/Sulfites

- A. Except as specified in (B)-(D) of this section and except for whole, raw fruits and vegetables that are intended for washing by the consumer before consumption, raw fruits and vegetables shall be thoroughly washed in running drinking water to remove soil and other contaminants before being cut, combined with other ingredients, cooked, served, or offered for human consumption in ready-to-eat form. Commercially, prewashed raw fruits and vegetables that are prepackaged to prevent contamination do not require further washing prior to use.
- B. Fruits and vegetables from which rinds, peels, husks, or shells are not removed before preparation require washing.
- C. Chemicals for washing fruits and vegetables, criteria.
 - *1. Chemicals used to wash or peel raw, whole fruits and vegetables shall meet the requirements specified in 21 CFR 173.315, "Chemicals used in washing or to assist in the peeling of fruits and vegetables".
 - 2. Ozone as an antimicrobial agent used in the treatment, storage, and processing of fruits and vegetables in a food establishment shall meet the requirements specified in 21 CFR 173.368.
- *D. Application of sulfiting agents to fresh fruits and vegetables intended for raw consumption or to a food considered to be a good source of vitamin B₁, such as poultry, crab meat (except canned), mixed nuts, whole grains, whole grain flours, enriched bakery products is prohibited.
- E. New or extensively remodeled establishments with food items that require washing shall have a food preparation sink. The food preparation sink must be supplied with both hot and cold running water, must be indirectly drained to sewer and must be equipped with an approved eighteen inch (18") [(46 centimeters (cm))] drain board or an alternate drain table or work space approved by the Department. If a garbage disposal is to be installed at the food preparation sink, it shall be located in the drain board of the sink and must be plumbed in accordance with section 5-205.

- F. In establishments licensed prior to the effective date of these regulations, where vegetable preparation is limited to a few items and in limited quantity, and either single-service tableware or a mechanical dishwasher is used, the three- compartment warewashing sink may be used for food preparation if the sink is indirectly drained and the sink and drain boards are cleaned and sanitized between changes in use.
- G. A food preparation sink may only be used for washing food, cooling, thawing and other food preparation activities.

3-409 In-Use Utensils, Between Use Storage

- A. To avoid unnecessary manual contact with the food, suitable dispensing utensils and single-service articles shall be used by employees and consumers. Consumer display and self-service of bulk food shall meet the requirements of section 25-4-1301 et seq., C.R.S., (See Appendix H). Except as specified in 5 and 6, dispensing utensils shall be:
 - 1. Stored in the food with the dispensing utensil handle extended out of the food; or
 - 2. Stored on a clean and sanitized surface, if washed and sanitized in accordance with section 4-407(C); or
 - 3. Stored in continuously flowing drinking water such as in a dipper well; or
 - 4. Stored at temperatures of 135°F (57°C) and above, or 41°F (5°C) and below.
 - 5. Utensils may not be stored in cracks and crevices between equipment.
 - 6. In-use utensils may not be stored in sanitizing or cleaning solutions.
- B. Ice for human consumption shall be dispensed only by employees with scoops, tongs, or other ice dispensing utensils, or through automatic self-service, ice dispensing equipment. Ice dispensing utensils shall be stored on a clean surface or in the ice with the dispensing utensil's handle extended out of the ice. Between uses, ice transfer receptacles shall be stored in a way that protects them from contamination.

3-410 Wiping Cloths

- A. Cloths used for wiping food spills on food-contact surfaces shall be cleaned and rinsed frequently in one of the sanitizing solutions permitted in Appendix F of these rules and regulations and used for no other purpose. These cloths shall be held between uses in a clean, chemical sanitizer solution at the proper concentration.
- B. Cloths used for cleaning nonfood-contact surfaces shall be clean and rinsed as specified in paragraph A of this section and used for no other purpose. These cloths shall be held between uses in a clean, chemical sanitizer solution at the proper concentration.
- C. Cloths that are used with raw foods of animal origin shall be kept separate from cloths used for other purposes. Cloths used with raw foods of animal origin shall be kept in a separate sanitizing solution.
- D. Dry, single-use disposable towels are permitted for wiping food spills in lieu of wiping cloths if discarded after each use.
- E. Cloths used for wiping food spills on tableware, such as plates and bowls being served to the consumer, shall be clean, dry, and used for no other purpose.
- F. Sponges shall not be used in contact with food-contact surfaces.
- G. Wet wiping cloths shall be laundered daily.

- H. Dry wiping cloths shall be laundered as necessary to prevent contamination of food and clean serving utensils.

3-411 Re-Use of Tableware

- A. Except as specified in B, re-use of soiled tableware is prohibited.
- B. Beverage cups and glasses may be refilled where filling equipment is designed to prevent cross-contamination provided that the actuating lever or mechanism and filling device of beverage dispensing equipment is designed to prevent contact with the lip-contact surface of glasses or cups that are being refilled.

3-412 Refilling Returnables

- A. A take-home or personal food container shall not be refilled at a retail food establishment with a potentially hazardous food (time/temperature control for safety food).
- B. Returnables refilled with food that is not potentially hazardous shall be clean.
- C. Personal take-out beverage containers, such as thermally insulated bottles, nonspill coffee cups, and promotional beverage glasses, may be refilled by employees or the consumer if refilling is a contamination-free process.

3-413 Food Storage

- A. Containers of food shall be stored a minimum of six inches (6") [15 centimeters (cm)] above the floor or stored on dollies, skids, racks, or open-ended pallets, provided such equipment is easily movable, either by hand or with the use of pallet-moving equipment that is on the premises and used. Such storage areas shall be kept clean.
- B. Pressurized beverage containers, cased food in waterproof containers such as bottles or cans, milk containers in plastic crates, and waterproof, easily moveable, covered containers may be stored on a floor that is clean and not exposed to floor moisture.
- C. Packaged food, once the container is opened in the retail food establishment prior to use or retail sale, shall be kept covered. Food, whether raw or prepared, if removed from the container in which it was originally packaged, shall be stored in a clean, covered container, except during necessary periods of preparation or cooling. Foods uncovered during preparation or cooling must be protected from contamination.

Primal cuts, quarters or sides of meat, or processed meats, such as country hams, slab bacon, and smoked or cured sausages, may be hung uncovered or placed on clean, sanitized metal racks in such a manner as to preclude contamination of any food products in storage.

3-414 Food Storage, Prohibited Areas

Food may not be stored:

- A. In locker areas unless the food is completely packaged;
- B. In toilet rooms and their vestibules;
- C. In dressing rooms;
- D. In rooms designated for garbage, recycling or composting collection;
- E. In mechanical rooms;

- F. Under sewer lines that are not shielded to intercept potential drips;
- G. Under leaking water lines, including leaking automatic fire sprinkler heads, or under lines on which water has condensed;
- H. Under open stairwells;
- I. Under other sources of contamination; or
- J. In a private home.

3-415 Food Display

- A. Except for nuts in the shell and whole, raw fruits and vegetables that are intended for hulling, peeling, or washing by the consumer before consumption, food on display shall be protected from contamination by the use of packaging; food shields at counters, service lines, or salad bars; display cases; or other effective means of protection.
- B. French style, hearth baked or hard-crustured loaves and rolls may be considered properly wrapped if contained in an open-end bag of sufficient size to enclose the loaves or rolls.
- C. Bulk food that is available for consumer self-dispensing shall meet the requirements of section 25-4-1301 et seq., C.R.S., (See Appendix H).

3-416 Condiments, Protection

- A. Condiments shall be protected from contamination by being kept in protective dispensers, in food displays that meet the requirements of section 3-311 (A) and are provided with the proper utensils, in original containers that are designed for dispensing, or in individual packages or portions.
- B. Adding additional product before the container is emptied, cleaned and sanitized is prohibited.

***3-417 Consumer Self-Service Operations**

- A. Unpackaged or unwrapped raw animal food, such as beef, lamb, pork, poultry and fish shall not be offered for consumer self-service. This does not apply to consumer self-service of ready-to-eat foods at buffets or salad bars that serve foods such as sushi or raw shellfish, or to ready-to-cook individual portions for immediate cooking and consumption on the premises such as consumer-cooked meats or consumer-selected ingredients for Mongolian barbecue.
- B. Consumer self-service operations such as buffets and salad bars shall be monitored by food employees trained in safe operating procedures.

***3-418 Reservice**

Once served to a consumer, portions of leftover food shall not be served again except that packaged food, other than potentially hazardous food (time/temperature control for safety food), that is still in an unopened package and is still in sound condition, may be re-served.

3-5 DESTRUCTION OF ORGANISMS OF PUBLIC HEALTH CONCERN

***3-501 Temperature**

- A. The temperature of potentially hazardous foods (time/temperature control for safety foods) shall be 41°F (5°C) or below or 135°F (57°C) or above, at all times, except during necessary periods of preparation or as otherwise provided in this code.
- B. Equipment for cooling, heating and holding food, cold and hot, shall be sufficient in number and capacity to provide required food temperatures.
- C. Fluid milk and milk products, molluscan shellstock, and shell eggs may be received at their respective temperatures according to laws governing their distribution.
- D. A food that is labeled frozen and shipped frozen by a food processing plant shall be received and stored frozen.
- E. Upon receipt, potentially hazardous food (time/temperature control for safety food) shall be free of evidence of previous temperature abuse.

***3-502 Cooking Potentially Hazardous Foods (Time/Temperature Control For Safety Foods)**

Potentially hazardous foods (time/temperature control for safety foods) processed within the retail food establishment shall be cooked to a uniform internal temperature of 135°F (57°C), except that:

- A. Poultry, stuffed ratite, stuffed fish, stuffed meat, stuffed pasta, stuffed poultry, or stuffing containing fish, meat or poultry shall be cooked to a minimum internal temperature of at least 165°F (74°C) for 15 seconds.
- B. Whole meat roasts including beef, corned beef, lamb, pork, and cured pork roasts such as ham shall be cooked:
 - 1. In an oven that is preheated to the temperature specified for the roast's weight in the following chart and that is held at that temperature:

OVEN TYPE	OVEN TEMPERATURE BASED ON ROAST WEIGHT	
	LESS THAN 10 LBS (4.5 KG)	10 LBS(4.5 KG) OR MORE
STILL DRY	350°F (177°C) OR MORE	250°F (121°C) OR MORE
CONVECTION	325°F (163°C) OR MORE	250°F (121°C) OR MORE
HIGH HUMIDITY ¹	250°F (121°C) OR LESS	250°F (121°C) OR LESS

¹ RELATIVE HUMIDITY GREATER THAN 90% FOR AT LEAST 1 HOUR AS MEASURED IN THE COOKING CHAMBER OR EXIT OF THE OVEN; OR IN A MOISTURE-IMPERMEABLE BAG THAT PROVIDES 100% HUMIDITY.

and

2. As specified in the following chart, to heat all parts of the food to a temperature and for the holding time that corresponds to that temperature:

TEMPERATURE °F °C	TIME ¹ IN MINUTES	TEMPERATURE °F °C	TIME ¹ IN SECONDS
130°F (54.4°C)	112	147°F (63.9°C)	134
131°F (55.0°C)	89	149°F (65.0°C)	85
133°F (56.1°C)	56	151°F (66.1°C)	54
135 (57.2°C)	36	153°F (67.2°C)	34
136°F (57.8°C)	28	155°F (68.3°C)	22
138°F (58.9°C)	18	157°F (69.4°C)	14
140°F (60.0°C)	12	158°F (70.0°C)	0
142°F (61.1°C)	8		
144°F (62.2°C)	5		
145°F (62.8°C)	4		
¹ <i>HOLDING TIME MAY INCLUDE POST OVEN HEAT RISE.</i>			

- C. A raw or undercooked whole-muscle, intact beef steak may be served or offered for sale in a ready-to-eat form if:
1. The food establishment serves a population that is not a highly susceptible population;
 2. The steak is labeled to indicate that it meets the definition of "whole-muscle, intact beef"; and
 3. The steak is cooked on both the top and bottom to a surface temperature of 145°F (63°C) or above and a cooked color change is achieved on all external surfaces.
- D. Eggs, pork, lamb, fish and other meats as defined in section 1-202 (35) shall be cooked to a minimum internal temperature of 145°F (63°C) for 15 seconds.
- E. Eggs that are not prepared in response to a consumer's order or for immediate service shall be cooked to 155°F (68°C).
- F. Ground beef and ratites shall be cooked to a minimum internal temperature of 155°F (68°C) for 15 seconds, or to 145°F (63°C) for 3 minutes, or 150°F (66°C) for 1 minute, or 158°F (70°C) for less than one second.
- G. Game animals shall be cooked to a minimum internal temperature of 145°F (63°C) for 15 seconds except as specified in section 3-502 (K) of these rules and regulations.
- H. Comminuted fish, meat and game animals and beef including mechanically tenderized or injected meats other than whole muscle intact beef steak, shall be cooked to a minimum internal temperature of 155°F (68°C) for 15 seconds.
- I. Raw animal foods cooked in a microwave oven shall be:
1. Rotated or stirred throughout or midway during cooking to compensate for uneven distribution of heat
 2. Covered to retain surface moisture

3. Heated to a temperature of at least 165°F (74°C) in all parts of the food; and
 4. Allowed to stand covered for 2 minutes after cooking to obtain temperature equilibrium.
- J. Fruits and vegetables that are cooked for hot holding shall be cooked to a temperature of 135°F (57°C).
- K. Unless otherwise ordered by the immediate consumer and the consumer is informed as specified in sections 1(a)-(c) below:
1. A raw animal food such as raw egg, raw fish, raw-marinated fish, raw molluscan shellfish, or steak tartare; or a partially cooked food such as lightly cooked fish, soft cooked eggs, or rare meat other than whole-muscle, intact beef steaks as specified in (c) of this section, may be served or offered for sale upon consumer request or selection in a ready-to-eat form if:
 - a. As specified in section 3-702(A)-(C) of these rules and regulations, the food establishment serves a population that is not a highly susceptible population;
 - b. The food, if served or offered for service by consumer selection from a children's menu, does not contain comminuted meat; and
 - c. The consumer is informed as specified in part 3-8 "Consumer Advisory" that to ensure its safety, the food should be cooked as specified in section 3-502(A)-(K) of this section.

***3-503 Non-Continuous Cooking of Raw Animal Foods**

- A. Raw animal foods that are cooked using a non-continuous cooking process shall be:
1. Subject to an initial heating process that is no longer than sixty minutes in duration;
 2. Immediately after initial heating, cooled according to the time and temperature parameters specified for cooked potentially hazardous food (time /temperature control for safety food) in section 3-603(A) of these rules and regulations;
 3. After cooling, held frozen or cold, as specified for potentially hazardous food (time/temperature control for safety food) in section 3-501(A) of these rules and regulations;
 4. Prior to sale or service, cooked using a process that heats all parts of the food to a temperature of at least 165°F (74°C) for 15 seconds;
 5. Cooled according to the time and temperature parameters specified for cooked potentially hazardous food (time /temperature control for safety food) in section 3-603(A)-(C) if not either hot held as specified in section 3-501(A), served immediately, or held using time as a public health control as specified in section 3-605(A)-(B) after complete cooking; and
 6. Prepared and stored according to written procedures approved by the Department that:
 - a. Are maintained in the food establishment and are available to the Department upon request;

- b. Describe how the requirements specified in (1)-(5) of this Section are to be monitored and documented by the licensee and the corrective actions to be taken if the requirements are not met;
- c. Describe how the foods, after initial heating, but prior to complete cooking, are to be marked or otherwise identified as foods that must be cooked as specified in (4) of this section prior to being offered for sale or service; and
- d. Describe how the foods, after initial heating but prior to cooking as specified in section (4) of this section, are to be separated from ready-to-eat foods as specified in section 3-406.

***3-504 Reheating**

- A. Except as specified in paragraphs (B) and (C) of this section, potentially hazardous foods (time/temperature control for safety foods) that have been cooked and then refrigerated shall be rapidly reheated within two hours to a uniform internal temperature of 165°F (74°C) or higher before being placed in hot food storage holding units which shall maintain product temperature at 135°F (57°C) or above at all times. Food warmers and other hot food holding units shall not be used to reheat potentially hazardous foods (time/temperature control for safety foods) unless the equipment is specifically designed for that purpose.
- B. Except as specified in paragraph (C) of this section, food reheated in a microwave oven shall be heated to a uniform internal temperature of at least 165°F (74°C) and the food is rotated or stirred, covered, and allowed to stand covered for 2 minutes after reheating.
- C. Ready-to-eat food taken from a commercially processed, hermetically sealed container, or from an intact package from a food processing plant that is inspected by the food Department that has jurisdiction over the plant, shall be heated within two hours to a uniform internal temperature of at least 135°F (60°C) for hot holding.

***3-505 Preparation for Immediate Service**

Cooked and refrigerated food that is prepared for immediate service in response to an individual consumer order, such as a roast beef sandwich au jus, may be served at any temperature.

3-6 LIMITATION OF GROWTH OF ORGANISMS OF PUBLIC HEALTH CONCERN

3-601 Thawing

Except as specified in subparagraph (D) of this section, potentially hazardous foods (time/temperature control for safety foods) shall be thawed:

- *A. Under refrigeration that maintain the food temperature at 41°F (5°C) or less; or
- B. Completely submerged and with packaging removed under running water:
 - 1. At a water temperature of 70°F (21°C) or below,
 - 2. With sufficient water velocity to agitate and float off loose particles in an overflow, and
 - *3. For a period of time that does not allow thawed portions of ready-to-eat food to rise above 41°F (5°C), or

- *4. For a period of time that does not allow thawed portions of a raw animal food requiring cooking as specified in section 3-502 to be above 41°F (5°C), for more than 4 hours including:
 - a. The time the food is exposed to the running water and the time needed for preparation for cooking, or
 - b. The time it takes under refrigeration to lower the food temperature to 41°F (5°C);
- C. As part of a cooking process if the food that is frozen is:
 - 1. Cooked as specified in section 3-502, or
 - 2. Thawed in a microwave oven and immediately transferred to conventional cooking equipment, with no interruption in the process; or
- D. Using any procedure if a portion of frozen ready-to-eat food is thawed and prepared for immediate service in response to an individual consumer's order.

3-602 Slacking

- A. Frozen potentially hazardous food (time/temperature control for safety food) that is slacked to moderate the temperature shall be held:
 - *1. Under refrigeration that maintains the food temperature at 41°F (5°C) or less, or
 - 2. At any temperature if the food remains frozen.

***3-603 Cooling**

- A. Cooked potentially hazardous foods (time/temperature control for safety foods) shall be cooled from 135°F (57°C) to 41°F (5°C), or below, in 6 hours, provided that the food is cooled from 135°F (57°C) to 70°F (21°C) within the first 2 hours.
- B. Potentially hazardous foods (time/temperature control for safety foods) that has been prepared from ingredients at ambient temperature, such as reconstituted milk and canned products, shall be cooled to 41°F (5°C), or below, within 4 hours.
- C. Fluid milk and milk products, shell eggs, and molluscan shellstock received in compliance with laws regulating the respective food during shipment from the supplier shall be cooled to 41°F (5°C) or below within 4 hours.

3-604 Cooling Methods

- A. Cooling shall be accomplished as required in section 3-603, by using one or more of the following methods based on the type of food being cooled:
 - 1. Placing the food in shallow pans;
 - 2. Separating the food into smaller or thinner portions;
 - 3. Using rapid cooling equipment;
 - 4. Stirring the food in a container placed in an ice water bath;
 - 5. Using containers that facilitate heat transfer;
 - 6. Adding ice as an ingredient; or

7. Other effective methods that meet the requirements of section 3-603 of these rules and regulations.
- B. When using food containers to cool food, food shall be:
1. Arranged in the container to provide maximum heat transfer through the container walls; and
 2. Loosely covered, or uncovered if protected from overhead contamination during the cooling period to facilitate heat transfer from the surface of the food.

3-605 Time as a Public Health Control

- *A. Except as specified in paragraph (D) of this section, if time without temperature control is used as the public health control for a working supply of potentially hazardous food (time/temperature control for safety food) before cooking, or for ready-to-eat potentially hazardous food (time/temperature control for safety food) that is displayed or held for sale or service:
1. Written procedures shall be prepared in advance, maintained in the food establishment and made available to the Department upon request that specify:
 - a. Methods of compliance with subparagraphs (B)(1)-(3) or (C)(1)-(5) of this section; and
 - b. Methods of compliance in section 3-501 of these rules and regulations for food that is prepared, cooked, and refrigerated before time is used as a public health control.
- *B. If time temperature control is used as the public health control up to a maximum of 4 hours:
1. The food shall have an initial temperature of 41°F (5°C) or less when removed from cold holding temperature control, or 135°F (57°C) or greater when removed from hot holding temperature control;
 2. The food shall be marked or otherwise identified to indicate the time that is 4 hours past the point in time when the food is removed from temperature control;
 3. The food shall be cooked and served, served at any temperature if ready-to-eat, or discarded, within 4 hours from the point in time when the food is removed from temperature control; and
 4. The food in unmarked containers or packages, or marked to exceed a 4-hour limit shall be discarded.
- *C. If time without temperature control is used as the public health control up to a maximum of 6 hours:
1. The food shall have an initial temperature of 41°F (5°C) or less when removed from temperature control and the food temperature may not exceed 70°F (21°C) within a maximum time period of 6 hours;
 2. The food shall be monitored to ensure the warmest portion of the food does not exceed 70°F (21°C) during the 6-hour period, unless an ambient air temperature is maintained that ensures the food does not exceed 70°F (21°C) during the 6-hour holding period;
 3. The food shall be marked or otherwise identified to indicate:

- a. The time when the food is removed from 41°F (5°C) or less cold holding temperature control, and
 - b. The time that is 6 hours past the point in time when the food is removed from cold holding temperature control;
- 4. The food shall be:
 - a. Discarded if the temperature of the food exceeds 70°F (21°C), or
 - b. Cooked and served, served at any temperature if ready-to-eat, or discarded within a maximum of 6 hours from the point in time when the food is removed from 41°F (5°C) or less cold holding temperature control; and
- 5. The food in unmarked containers or packages, or marked with a time that exceeds the 6-hour limit shall be discarded.
- D. A food establishment that serves a highly susceptible population may not use time as specified in section (A), (B) or (C) of this section as the public health control for raw eggs.

***3-606 Specialized Processing Methods**

- A. Unless otherwise approved by the Department, a retail food establishment shall develop a HACCP plan and except in (4) of this section, obtain written approval from the Department prior to engaging in any of the following:
 - 1. Smoking food as a method of food preservation rather than as a method of flavor enhancement;
 - 2. Curing food;
 - 3. Using food additives or adding components to alter the pH or Water Activity:
 - a. As a method of food preservation rather than as a method of flavor enhancement, or
 - b. To render a food so that it is not potentially hazardous.
 - 4. Packaging food using a reduced oxygen packaging method except as specified in section 3-607 where a barrier to clostridium botulinum in addition to refrigeration exists;
 - 5. Operating a molluscan shellfish life-support system display tank used to store or display shellfish that are offered for human consumption;
 - 6. Custom processing animals that are for personal use as food and not for sale or service in a food establishment;
 - 7. Sprouting seeds or beans;
 - 8. Other specialized processing methods.

***3-607 Reduced Oxygen Packaging**

- A. A retail food establishment that packages potentially hazardous food (time/temperature control for safety food) using a reduced oxygen packaging method shall control the growth and toxin formation of *Clostridium botulinum* and the growth of *Listeria monocytogenes* and have a HACCP plan that contains the information specified under Appendix G and that:
1. Identifies the food to be packaged;
 2. Except as specified in (B) - (D) of this section, requires that the packaged food shall be maintained at 41°F (5°C) or less and meet at least one of the following criteria:
 - a. Has an a_w of 0.91 or less,
 - b. Has a pH of 4.6 or less,
 - c. Is a meat or poultry product cured at a food processing plant regulated by the U.S. Department of Agriculture (USDA) using substances specified in 9 CFR 424.21, use of food ingredients and sources of radiation, and is received in an intact package; or
 - d. Is a food with a high level of competing organisms such as raw meat or raw poultry or raw vegetables.
 3. Describes how the package shall be prominently and conspicuously labeled on the principal display panel in bold type on a contrasting background, with instructions to:
 - a. Maintain the food at 41°F (5°C) or below, and
 - b. Discard the food if within fourteen (14) calendar days of its packaging it is not served for on-premises consumption, or consumed if served or sold for off-premises consumption;
 4. Limits the refrigerated shelf life to no more than fourteen (14) calendar days from packaging to consumption, except the time the product is maintained frozen, or the original manufacturer's "sell by" or "use by" date, whichever occurs first;
 5. Includes operational procedures that:
 - a. Prohibit contacting ready-to-eat food with bare hands as specified in section 3-302 of these rules and regulations,
 - b. Identify a designated work area and the method by which:
 - (1) Physical barriers or methods of separation of raw foods and ready-to-eat foods minimize cross contamination, and
 - (2) Access to the processing equipment is limited to responsible trained personnel familiar with the potential hazards of the operation, and
 - c. Delineate cleaning and sanitization procedures for food-contact surfaces; and

6. Describes the training program that ensures that the individual responsible for the reduced oxygen packaging operation understands the:
 - a. Concepts required for a safe operation,
 - b. Equipment and facilities, and
 - c. Procedures specified under Subparagraph (A)(5) of this section and Appendix G.
- B. Except for fish that is frozen before, during, and after packaging, a food establishment may not package fish using a reduced oxygen packaging method.
- C. Except as specified in (B) of this section, a food establishment that packages potentially hazardous food (time/temperature control for safety food) food using a cook-chill or sous vide process shall:
 1. Implement a HACCP plan that contains the information as specified in Appendix G;
 2. Ensure the food is:
 - a. Prepared and consumed on the premises, or prepared and consumed off the premises but within the same business entity with no distribution or sale of the packaged product to another business entity or the consumer,
 - b. Cooked to heat all parts of the food to a temperature and for a time as specified in section 3-502,
 - c. Protected from contamination before and after cooking as specified in section 3-401 through 3-406,
 - d. Placed in a package with an oxygen barrier and sealed before cooking, or placed in a package and sealed immediately after cooking and before reaching a temperature below 57°C (135°F),
 - e. Cooled to 41°F (5°C) in the sealed package or bag as specified in section 3-503 and:
 - (1) Cooled to 34°F(1°C) within 48 hours of reaching 41°F (5°C) and held at that temperature until consumed or discarded within thirty (30) days after the date of packaging;
 - (2) Held at 41°F (5°C) or less for no more than 7 days, at which time the food must be consumed or discarded; or
 - (3) Held frozen with no shelf life restriction while frozen until consumed or used.
 - f. Held in a refrigeration unit that is equipped with an electronic system that continuously monitors time and temperature and is visually examined for proper operation twice daily,
 - g. If transported off-site to a satellite location of the same business entity, equipped with verifiable electronic monitoring devices to ensure that times and temperatures are monitored during transportation; and
 - h. Labeled with the product name and the date packaged; and

3. Maintain the records required to confirm that cooling and cold holding refrigeration time/temperature parameters are met as part of the HACCP plan and:
 - a. Make such records available to the Department upon request, and
 - b. Hold such records for at least 6 months; and
 4. Implement written operational procedures as specified in (A)(5) of this section and a training program as specified in (A)(6) of this section.
- D. A food establishment that packages cheese using a reduced oxygen packaging method shall:
1. Limit the cheeses packaged to those that are commercially manufactured in a food processing plant with no ingredients added in the food establishment and that meet the Standards of Identity as specified in 21 CFR 133.150 Hard cheeses, 21 CFR 133.169 Pasteurized process cheese or 21 CFR 133.187 Semisoft cheeses;
 2. Have a HACCP plan that contains the information specified under appendix G and as specified in (A)(1), (A)(3)(a), (A)(5) and (A)(6) of this section;
 3. Labels the package on the principal display panel with a "use by" date that does not exceed thirty (30) days from its packaging or the original manufacturer's "sell by" or "use by" date, whichever occurs first; and
 4. Discards the reduced oxygen packaged cheese if it is not sold for off-premises consumption or consumed within thirty (30) calendar days of its packaging.
- E. When applying a reduced oxygen packaging process, retail food establishments shall notify the Department in advance and indicate the method proposed (i.e. cook-chill, sous vide).

3-608 Breeding Mixtures

- A. Containers of dry breeding mixtures (containing flour, cornmeal, spices, etc.) into which raw animal foods such as poultry and fish are repeatedly dipped, may be used for a total period of up to 7 days and stored at room temperature, provided that:
 1. Containers are stored covered in a clean dry area overnight and/or when not in use as specified in sections 3-311 and 3-312;
 2. The breeding mixture is sifted at a minimum of every 4 hours to remove excess moisture and doughballs while in use; and
 3. Containers are completely emptied, cleaned and sanitized, and the breeding mixtures discarded at intervals of no greater than 7 days.
- B. If this procedure is used, the person in charge must have a system in place to indicate the date the breeding must be discarded.

3-7 ON-PREMISES LABELING

3-701 Labeling

- A. When voluntary code date information appears on a retail food establishment or manufacturers' label, it shall not be concealed or altered.
- B. Bulk food available for consumer self-dispensing shall be prominently labeled according to section 25-4-1301 et seq., C.R.S., (See Appendix H).
- C. If an unpackaged non-bulk food product is manufactured on site and sold at the site where it was manufactured or sold over the counter at a different site, no labeling is required. However, an ingredient label shall be made available upon request.

If a packed food product is manufactured and sold on or off site for customer self service, it must be labeled in accordance with section 25-5-401 et seq., C.R.S. and all labeling regulations authorized therein.

- D. A food ingredient, such as flour, sugar, salt, spices, dried herbs, potato flakes, baking powder, cooking oil or vinegar, that is not stored in the original package and is not readily identifiable on sight, shall be stored in a container identifying it by a common name.

3-702 Special Requirements for Highly Susceptible Populations

- A. Ready-to-Eat, Potentially Hazardous Food (Time/Temperature Control for Safety Food) served in facilities providing food to highly susceptible populations shall adhere to the following date marking requirements:
 - *1. Except when packaging food using a reduced oxygen packaging method as specified in section 3-607 of these rules and regulations, and except as specified in (4) and (5) of this section, refrigerated, ready-to-eat, potentially hazardous food (time/temperature control for safety food) prepared and held in a food establishment for more than 24 hours shall be clearly marked to indicate the date or day by which the food shall be consumed on the premises, sold, or discarded when held at a temperature of 41°F (5°C) or less for a maximum of 7 days.
 - *2. Except as specified in (4)-(6) of this section, refrigerated, ready-to-eat, potentially hazardous food (time/temperature control for safety food) prepared and packaged by a food processing plant shall be clearly marked, at the time the original container is opened in a food establishment and if the food is held for more than 24 hours, to indicate the date or day by which the food shall be consumed on the premises, sold, or discarded, based on the temperature and time combinations specified in (1) of this section and:
 - a. The day the original container is opened in the food establishment shall be counted as Day 1; and
 - b. The day or date marked by the food establishment may not exceed a manufacturer's use-by date if the manufacturer determined the use-by date based on food safety.
 - *3. A refrigerated, ready-to-eat, potentially hazardous food (time/temperature control for safety food) ingredient or a portion of a refrigerated, ready-to-eat, potentially hazardous food (time/temperature control for safety food) that is subsequently

combined with additional ingredients or portions of food shall retain the date marking of the earliest-prepared or first-prepared ingredient.

4. A date marking system that meets the criteria stated in (1) and (2) of this section may include:
 - a. Using a method approved by the Department for refrigerated, ready-to-eat potentially hazardous food (time/temperature control for safety food) that is frequently rewrapped, such as lunchmeat or a roast, or for which date marking is impractical, such as soft serve mix or milk in a dispensing machine
 - b. Marking the date or day of preparation, with a procedure to discard the food on or before the last date or day by which the food must be consumed on the premises, sold, or discarded as specified in (a) of this section;
 - c. Marking the date or day the original container is opened in a food establishment, with a procedure to discard the food on or before the last date or day by which the food must be consumed on the premises, sold, or discarded as specified in (b) of this section; or
 - d. Using calendar dates, days of the week, color-coded marks, or other effective marking methods, provided that the marking system is disclosed to the Department upon request.
5. Paragraphs (1) and (2) of this section do not apply to individual meal portions served or repackaged for sale from a bulk container upon a consumer's request.
6. Paragraph (2) of this section does not apply to the following foods prepared and packaged by a food processing plant inspected by a Department:
 - a. Deli salads, such as ham salad, seafood salad, chicken salad, egg salad, pasta salad, potato salad, and macaroni salad, manufactured in accordance with 21 CFR 110 Current good manufacturing practice in manufacturing, packing, or holding human food;
 - b. Hard cheeses containing not more than 39% moisture as defined in 21 CFR 133 Cheeses and related cheese products, such as cheddar, gruyere, parmesan and reggiano, and romano;
 - c. Semi-soft cheeses containing more than 39% moisture, but not more than 50% moisture, as defined in 21 CFR 133 Cheeses and related cheese products, such as blue, edam, gorgonzola, gouda, and monterey jack;
 - d. Cultured dairy products as defined in 21 CFR 131 Milk and cream, such as yogurt, sour cream, and buttermilk;
 - e. Preserved fish products, such as pickled herring and dried or salted cod, and other acidified fish products defined in 21 CFR 114 Acidified foods;
 - f. Shelf stable, dry fermented sausages, such as pepperoni and Genoa salami that are not labeled "Keep Refrigerated" as specified in 9 CFR 317 Labeling, marking devices, and containers, and which retain the original casing on the product; and

- g. Shelf stable salt-cured products such as prosciutto and Parma (ham) that are not labeled "Keep Refrigerated" as specified in 9 CFR 317 Labeling, marking devices, and containers.
- *B. A food establishment that packages potentially hazardous food (time/temperature control for safety food) that will be served in facilities providing food to highly susceptible populations using a reduced oxygen packaging method as specified in section 3-607 shall have a HACCP plan that contains the information specified under appendix G and that is provided to the Department for review and approval prior to implementation.
- *C. The following foods may not be served or offered for sale in a ready-to-eat form to persons in a highly susceptible population:
 1. Raw animal foods such as raw fish, raw-marinated fish, raw molluscan shellfish, and steak tartare;
 2. A partially cooked animal food such as lightly cooked fish, rare meat, soft cooked eggs that are made from raw shell eggs and meringue;
 3. Raw seed sprouts;
 4. Juice that is not pasteurized or treated under an HACCP plan as specified in Appendix G of these rules and regulations, or contains a warning label as specified in Section 3-312(B) of these rules and regulations;
- *D. Food may not be re-served to or from highly susceptible populations under the following conditions:
 1. Any food served to patients or clients who are under contact precautions in medical isolation or quarantine, or protective environment isolation may not be re-served to others outside.
 2. Packages of Food from any patients, clients, or other consumers should not be re-served to persons in protective environment isolation.

3-8 CONSUMER ADVISORY (Section Effective July 1, 2013)

***3-801 Consumption of Animal Foods That Are Raw, Undercooked, or Not Otherwise Processed to Eliminate Pathogens**

- A. Except as specified in 3-502(C) and Subparagraph 3-502(K)(1) and in 3-702(A)-(D), if an animal food such as beef, eggs, fish, lamb, milk, pork, poultry, or shellfish is served or sold raw, undercooked, or without otherwise being processed to eliminate pathogens, either in ready-to-eat form or as an ingredient in another ready-to-eat food, the licensee shall inform consumers of the significantly increased risk of consuming such foods by way of a disclosure and reminder, as specified in (B) and (C) of this section using brochures, deli case or menu advisories, label statements, table tents, placards, or other effective written means.
- B. Disclosure shall include:
 1. A description of the animal-derived foods, such as “oysters on the half shell (raw oysters),” “undercooked eggs,” and “hamburgers (can be cooked to order);” or

2. Identification of the animal-derived foods by asterisking them to a footnote that states that the items are served raw or undercooked, or contain (or may contain) raw or undercooked ingredients.
- C. Reminder shall include asterisking the animal-derived foods requiring disclosure to a footnote that states:
1. Regarding the safety of these items, written information is available upon request;
 2. Consuming raw or undercooked meats, poultry, seafood, shellfish, or eggs may increase your risk of foodborne illness; or
 3. Consuming raw or undercooked meats, poultry, seafood, shellfish, or eggs may increase your risk of foodborne illness, especially if you have certain medical conditions.

CHAPTER 4

WAREWASHING, EQUIPMENT, UTENSILS, AND LINENS

4-1 MATERIALS FOR CONSTRUCTION AND REPAIR

4-101 General

All equipment, utensils and single-service articles shall be fabricated with safe materials; be of commercial design, that is certified or classified for sanitation by an American National Standards Institute (ANSI) accredited certification program or a design approved by the Department (see Appendix I); fabricated for durability under conditions of normal use; and resistant to denting, buckling, pitting, chipping, and crazing. Equipment, utensils, and single-service articles shall not impart odor, color, or taste, nor in any manner contribute to the contamination of food. Equipment and utensils shall be repaired with safe materials and maintained in good repair to comply with the requirements of this code.

4-102 Equipment Requirements

All retail food establishments shall have at a minimum:

- A. Equipment and utensil washing facilities installed and operated in accordance with section 4-403 except retail food establishments that do not prepare food, package food, or dispense unpackaged food other than whole, uncut raw fruits and vegetables, and whole nuts in the shell;
- B. At least one manual handsink accessible to employees involved in food preparation and equipment and utensil washing in accordance with section 5-208; and
- C. A utility facility in accordance with section 5-210.

4-2 DESIGN AND CONSTRUCTION

4-201 Food Contact Surfaces

Multi-use food-contact surfaces shall be:

- A. Smooth;
- B. Free of breaks, open seams, cracks, chips, pits, and similar imperfections;
- C. Free of sharp internal angles, corners, and crevices;
- D. Finished to have smooth welds and joints; and
- E. Accessible for cleaning and inspection by one of the following methods:
 - 1. Without being disassembled,
 - 2. By disassembly without the use of tools, or
 - 3. By easy disassembly with the use of only simple tools, such as mallets, screw drivers, or wrenches, that are kept in a readily accessible location near the equipment.

4-202 Use Limitations

- A. Cast iron may only be used as a cooking surface which can include use in the service of food when used in an uninterrupted process from cooking through service.
- *B. Ceramic, china, crystal utensils, and decorative utensils, such as hand-painted ceramic or china, that are used in contact with food shall be lead-free or contain levels of lead not exceeding the limits of the following utensil categories:

UTENSIL CATEGORY	DESCRIPTION	MAXIMUM LEAD mg/L
Beverage Mugs, Cups, Pitchers	Coffee Mugs	0.5
Large Hollowware (excluding pitchers)	Bowls \geq 1.1 L (1.16 QT)	1
Small Hollowware (excluding cups and mugs)	Bowls $<$ 1.1 L (1.16 QT)	2.0
Flat Tableware	Plates, Saucers	3.0

- *C. Copper and copper alloys, such as brass, may not be used in contact with food that has a pH below 6 (e.g. vinegar, fruit juice, wine, carbonated beverage, etc.).
Copper and copper alloys may be used in contact with beer brewing ingredients that have a pH below 6 in the prefermentation and fermentation steps of a beer brewing operation such as a brewpub or microbrewery.
- D. Enamelware shall not be used for storage or preparation of acidic foods (e.g. vinegar, tomato based sauces, juices, etc.).
- *E. Galvanized metal may not be used to fabricate food-contact surfaces of equipment that is used for beverages, moist food, or hygroscopic food.
- F. Linens and napkins may not be used in contact with food unless they are used to line a container for the service of foods and the linens and napkins are replaced each time the container is refilled for a new consumer.
- G. Clean cloth gloves may be used in direct contact with food that will be subsequently cooked as required as specified in part 3-5 of these rules and regulations, such as frozen food or a primal cut of meat.
- H. Pewter alloys containing lead in excess of 0.05% may not be used as a food-contact surface.
- I. Solder and flux containing lead in excess of 0.2%, and cadmium, antimony, bismuth, or other toxic chemicals may not be used on surfaces that contact food.
- J. Except as specified in paragraphs 1, 2, and 3 of this section, wood and wicker may not be used as a food-contact surface.
 - 1. Hard maple or an equivalently hard, close-grained, nonabsorbent wood, provided it is not cracked, pitted or uncleanable, may be used for:

- a. Cutting boards, cutting blocks, bakers' tables, bagel boards, and utensils such as rolling pins, doughnut dowels, salad bowls, pizza paddles, and chopsticks; and
 - b. Wooden paddles used in confectionery operations for pressure scraping kettles when manually preparing confections at a temperature of 230°F (110°C) or above.
- 2. Whole, uncut, raw fruits and vegetables, and nuts in the shell may be kept in the original wood or wicker containers until the fruits, vegetables, or nuts are used.
- 3. If the nature of the food requires removal of rinds, peels, husks, or shells before consumption, the whole, uncut, raw food may be kept in:
 - a. Untreated wood or wicker containers; or
 - b. Treated wood containers if the containers are treated with a preservative that meets the requirements specified by the Department in Preservatives for Wood, 21 CFR section 178.3800, (2008).
- K. Cutting surfaces that are scratched and scored must be resurfaced so as to be easily cleaned, or be discarded when these surfaces can no longer be effectively cleaned and sanitized.
- L. Wrapping of utensils or equipment handles with absorbent or difficult-to-clean material, such as string, wire or tape shall not be allowed.
- M. Newspaper, cloth, paper, oil cloth, cardboard, towels and other nonfood grade surfaces, such as grocery bags or retail store bags, are not approved food contact surfaces. This does not preclude the use of grocery bags for retail customers.

4-203 Nonfood-Contact Surfaces

Nonfood-contact surfaces shall be constructed of approved materials, in good repair, and be easily maintained in a clean and sanitary condition.

- A. In new or extensively remodeled retail food establishments, wood interior construction in walk-in cooler and freezer units shall be prohibited.
- B. Unfinished wood is not acceptable in food preparation, equipment or warewashing, or food storage areas other than those areas used solely as dry food storage areas.
- C. Surfaces of equipment or other areas, which are exposed to splash, food debris or which otherwise require frequent cleaning, shall be designed and fabricated to be smooth, durable, nonabsorbent, washable, free of unnecessary ledges, projections, or crevices, and readily accessible for cleaning.
- D. Wicker and wicker-like materials, in good repair can be used for service and display of prepackaged food. Service of bread or rolls in wicker or wicker-like materials is permissible if lined with dry linens or napkins, which are replaced each time the container is refilled for a new customer.
- E. Newspapers, cloth, paper, cardboard, towels, contact paper, foil, oil cloth, or similar materials shall not be used as liners for shelves, drawers, or drain boards.

4-204 Clean In Place (CIP) Equipment

- A. CIP equipment shall meet the characteristics of food-contact surfaces and shall be designed and constructed so that:

- *1. Cleaning and sanitizing solutions circulate throughout a fixed system and contact all interior food-contact surfaces; and
 - 2. The system is self-draining or capable of being completely drained of cleaning and sanitizing solutions.
- B. CIP equipment that is not designed to be disassembled for cleaning shall be designed with inspection access points to ensure that all interior food-contact surfaces throughout the fixed system are being effectively cleaned.

4-205 “V” Threads, Use Limitation

“V” type threads may not be used on food-contact surfaces, except for hot-oil cooking or filtering equipment.

4-206 Hot-Oil Filtering Equipment

Hot-oil filtering equipment shall meet the characteristics specified under food-contact surfaces as specified in section 4-201 or CIP equipment as specified in section 4-204 and shall be readily accessible for filter replacement and cleaning of the filter.

4-207 Bearings and Gear Boxes, Leakproof

Equipment containing bearings and gears requiring lubricants not made of safe materials shall be designed, constructed and maintained to ensure that the lubricant cannot leak, drip, or be forced into food or onto food-contact surfaces. Equipment designed to receive lubrication of bearings and gears on or within food-contact surfaces shall be lubricated with materials meeting the requirements of Lubricants, 21 CFR section 178.3570, (2008). (see Appendix E)

4-208 Beverage Tubing, Separation

Beverage tubing and cold-plate beverage cooling devices shall not be installed in contact with stored ice. This section does not apply to cold plates that are constructed integrally with an ice storage bin.

4-209 Ice Units, Separation of Drains

Liquid waste drain lines may not pass through an ice machine or ice storage bin.

4-210 Condenser Unit, Separation

If a condenser unit is an integral component of equipment, the condenser unit shall be separated from the food and food storage space by a dustproof barrier.

***4-211 Molluscan Shellfish Tanks**

- A. Except as specified in B of this section, molluscan shellfish life support system display tanks may not be used to store or display shellfish that are offered for human consumption and shall be conspicuously marked so that it is obvious to the consumer that the shellfish are for display only.
- B. Molluscan shellfish life-support system display tanks that are used to store or display shellfish that are offered for human consumption shall be operated and maintained in accordance with an approval granted by the department or an approved HACCP plan that:
 - 1. Is submitted by the licensee and approved as specified in section 11-403; and

2. Ensures that:
 - a. Water used with fish other than molluscan shellfish does not flow into the molluscan tank,
 - b. The safety and quality of the shellfish as they were received are not compromised by the use of the tank, and
 - c. The identity of the source of the shell stock is retained as specified in section 3-201(B).

4-212 Ventilation and Ventilation Hood Systems

All rooms shall have sufficient ventilation to keep them free of excessive heat, steam, condensation, vapors, obnoxious odors, smoke, and fumes. Ventilation systems shall comply with applicable building department and fire prevention bureau requirements, and when vented to the outside shall not create an unsightly, harmful, or unlawful discharge. Ventilation systems shall comply with 2006 International Mechanical Code (IMC). When local building and/or fire departments have adopted codes equivalent or more stringent than the above, those codes shall apply.

- A. Ventilation Hood Systems. Ventilation systems shall be sufficient in number, capacity, and designed and constructed according to 2006 International Mechanical Code, chapter 5, sections 507 and 508. Ventilation systems and devices shall be designed to prevent grease or condensation from collecting on walls and ceilings, and from dripping into food or onto food-contact surfaces. Hood filters or other grease extracting equipment shall be easily removable for cleaning and replacement when not designed for in place cleaning. Hood filters shall remain in place whenever the system is in operation.
- B. Equipment from which aerosols, obnoxious odors, noxious fumes, or vapors may originate shall be effectively vented to the outside air or vented through an approved ventilation system.
 1. Type I hoods shall be installed where cooking appliances produce grease or smoke such as occurs with grills, fryers, broilers, ranges and woks.
 2. Type II hoods shall be installed where cooking or dish washing appliances produce heat, steam or products of combustion but do not produce grease or smoke. This includes steamers, pasta cookers and high temperature sanitizing dish washing machines. This does not apply to under-counter-type commercial dishwashing machines.
 3. Intake and exhaust ducts shall be maintained to prevent the entrance of dust, dirt, and other contaminating materials.
 4. In new or extensively remodeled retail food establishments, restrooms shall be mechanically vented to the outside.
- C. Except for mobile retail food establishments, make up air must be filtered and mechanically introduced into the establishment at a volume equal to or greater than what is exhausted.
- D. Fire prevention, extinguishing equipment and lighting systems shall be installed in a ventilation system or hood so as to not create a cleaning problem.

4-3 LOCATION AND INSTALLATION

4-301 Equipment, and Storage Cabinets, Contamination Prevention.

- A. The storage of cleaned and sanitized equipment, utensils, laundered linens, laundered clothing and single-service and single-use articles may not be located:
1. In locker areas;
 2. In toilet rooms and their vestibules;
 3. In dressing rooms;
 4. In garbage, recycling, or composting rooms;
 5. In mechanical rooms;
 6. Under water and sewer lines that are not shielded to intercept potential drips;
 7. Under leaking automatic fire sprinkler heads, or under lines on which water has condensed;
 8. In a private home;
 9. Under open stairwells; or
 10. Under other sources of contamination.
- B. A storage cabinet used for linens or completely packaged single-service or single-use articles may be stored in a locker area.

4-302 Fixed Equipment, Spacing or Sealing

Equipment, including ice makers and ice storage equipment, shall not be located under sewer lines that are not shielded to intercept potential drips or under leaking water lines, including leaking automatic fire sprinkler heads, or under lines on which water has condensed.

A. Table-Mounted Equipment

1. Table-mounted equipment shall be installed to facilitate the cleaning of the equipment and the adjacent areas.
2. Equipment that is mounted on tables or counters, unless portable, shall be sealed to the table or counter, or elevated on legs to provide at least a 4-inch (10 cm) clearance between the table or counter, except that if no part of the table under the equipment is more than 18 inches (46 cm) from cleaning access, the clearance space shall be three (3) inches (8 cm) or more; or if no part of the table under the equipment is more than three (3) inches (8 cm) from cleaning access, the clearance space shall be two (2) inches (5 cm) or more.
3. Equipment is portable within the meaning of this section if:
 - a. It is small and light enough to be moved easily by one person; or
 - b. Is equipped with a mechanical means of safely tilting the unit for cleaning; and
 - c. It is table-mounted, such as powered mixers, grinders, slicers, tenderizers, and similar equipment; and

- d. It has no utility connection, has a utility connection that disconnects quickly, or has a flexible utility connection line of sufficient length to permit the equipment to be moved for easy cleaning.

B. Floor-Mounted Equipment

- 1. Floor-mounted equipment, unless easily moveable, shall be:
 - a. Sealed to the floor; or
 - b. Elevated on sanitary legs to provide at least a 6-inch (15 cm) clearance between the floor and equipment, except that equipment may be elevated to provide at least a 4-inch (10 cm) clearance between the floor and equipment if the floor under the equipment is no more than six (6) inches (15 cm) from cleaning access;
 - c. Display shelving units, display refrigeration units, and display freezer units are exempt from the provisions of Paragraph 1, a and b of this section if they are installed so that the floor beneath the units can be cleaned.
- 2. Equipment is easily moveable if:
 - a. It is mounted on commercially designed wheels or casters; and
 - b. It has no utility connection, or has a utility connection that disconnects quickly, or has a flexible utility line of sufficient length to permit the equipment to be moved for cleaning.
- 3. Grease-Use Equipment. Grease-use equipment, in which fats and oils are utilized as the heat transfer agent or which is used in preparation of foods that produce grease, shall be installed to facilitate cleaning around and beneath the equipment by means of:
 - a. Rollers or casters with a utility connection that disconnects quickly, or has a flexible utility line of sufficient design and length to permit the equipment to be moved for easy cleaning; or
 - b. Mounted on 6 inch (15.24 cm) sanitary legs; or
 - c. Cantilever mounted to the wall at least 6 inches (15.24 cm) above the floor.

C. Space Between Adjoining Units

- 1. The space between adjoining units, and between or above a unit and the adjacent wall or ceiling, shall be closed unless exposed to seepage, in which event it shall be sealed; or sufficient space shall be provided to facilitate easy cleaning between, behind, and beside or above all such equipment. (See Figure 1 and Figure 2)
- 2. Space required between or behind walls or equipment shall be based on the following distances: (See Figure 1 and Figure 2)
 - a. When distance “A” is 2 feet (0.61 M) or less, distance “B” must be at least 6 inches (15 cm).
 - b. When distance “A” is over 2 feet (0.61 M) but less than 6 feet (1.8 M), distance “B” must be at least 12 inches (30 cm).

- c. When distance “A” is 6 feet (1.8 M) or more, then distance “B” must be at least 18 inches (46 cm).
- 3. When rollers or casters are installed on equipment, the space requirements between adjoining units may not apply.

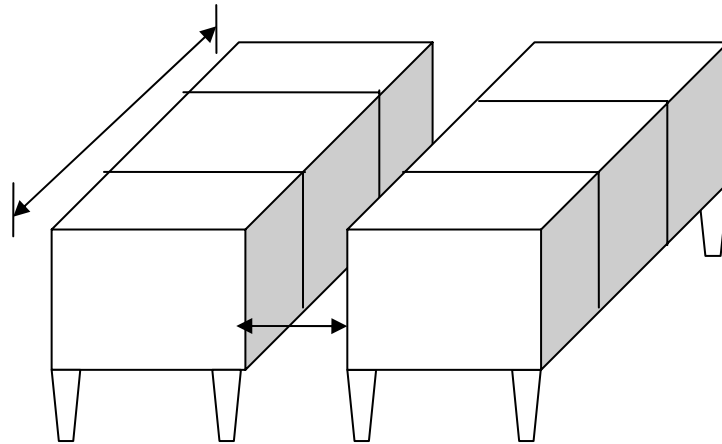

FIGURE 1

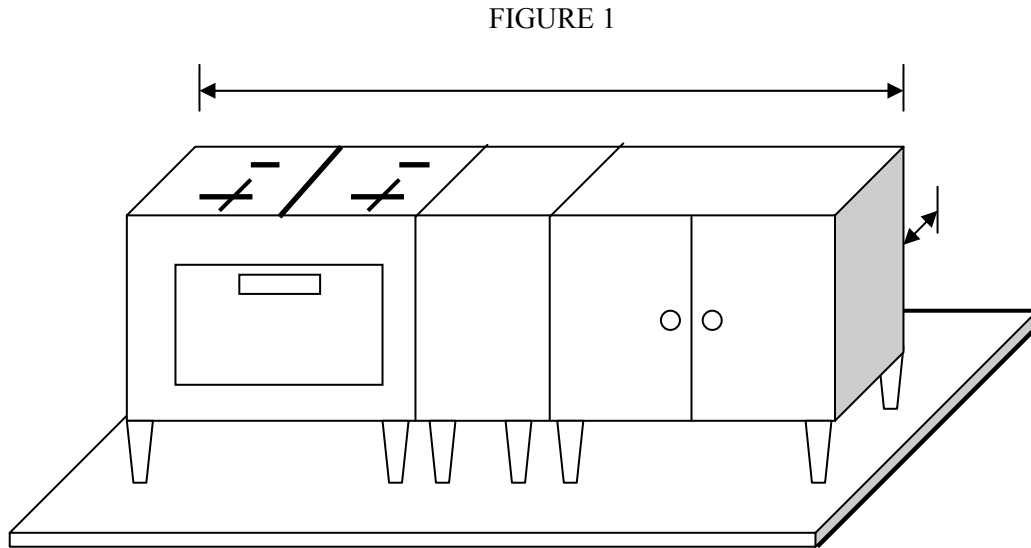

FIGURE 2

- D. Aisles and Working Spaces. Aisles and working spaces between units of equipment and between equipment and walls shall be unobstructed and of sufficient width to permit employees to perform their duties readily without contamination of food or food-contact surfaces by clothing or personal contact. All easily moveable storage equipment such as dollies, skids, racks, and open-ended pallets shall be positioned to provide accessibility to working areas.

- E. Kick Plates, Removable. Kick plates shall be designed so that the areas behind them are accessible for inspection and cleaning by being:
 - 1. Removable by one of the methods specified in section 4-201(E)(1-3) of these rules and regulations or capable of being rotated open; and
 - 2. Removable or capable of being rotated open without unlocking equipment doors.

4-4 EQUIPMENT AND UTENSIL CLEANING AND SANITIZATION - TESTING DEVICES

4-401 Temperature Measuring Devices

Temperature measuring devices shall be provided and used. Surfaces of food temperature measuring devices that come in contact with food shall be cleaned and sanitized before use or storage.

- *A. Temperature measuring devices shall be available, used, capable of reading both hot and cold temperatures, and shall have a numerical scale that includes the range of (0°-220°F), printed record, or digital readout in increments no greater than 2°F (1°C). Temperature measuring devices shall be used to determine required food temperature(s) and shall be accurate to $\pm 2^{\circ}\text{F}$ (1°C).
- *B. A temperature measuring device with a suitable small diameter probe that is capable of measuring the temperature of thin masses shall be provided and readily accessible to accurately measure the temperature in thin foods such as meat patties and fish fillets, if this type of food is prepared.
- C. Ambient air and warewashing temperature measuring devices shall have a numerical scale, printed record, or digital readout in increments no greater than 2°F or 1°C and shall be accurate to $\pm 3^{\circ}\text{F}$ (2°C).
- D. Each mechanically refrigerated and each hot food storage unit storing potentially hazardous food (time/temperature control for safety food) shall be provided with a numerically scaled indicating temperature measuring device. Temperature measuring devices used to measure the air temperature of cold holding units shall be conspicuously located in the upper one-third of the unit. Temperature measuring devices used to measure the air temperature of hot food storage units shall be conspicuously located in the lower one-third of the unit.
- E. Temperature measuring devices shall be checked and calibrated as necessary to ensure their accuracy.
- F. Where it is impractical to install temperature measuring devices on equipment, such as heat lamps, calrod units, or insulated food transport carriers, a temperature measuring device, as required in part A of this section, shall be available and used to check internal food temperature.

4-402 Testing Devices

- A. An appropriate test kit or other device designed to accurately measure the concentration in parts per million (mg/L) of the sanitizing solution shall be available and used.
- B. Where chemicals are used to wash fruits and vegetables in the establishment, the chemicals shall be prepared and used in accordance with the manufacture's labeled instructions.

- C. Where heat sanitization is used in mechanical warewashing machines, an accurate machine or water line mounted temperature gauge must be present. In the event a mounted temperature gauge is not present, an appropriate irreversible registering temperature indicator, such as a maximum read temperature, measuring device or heat sensitive tape shall be available and used to verify proper sanitization.

4-403 Manual Cleaning and Sanitization

In new or extensively remodeled retail food establishments, equipment and utensil washing facilities in accordance with section (A) of this section shall be provided for washing, rinsing, and sanitizing equipment and utensils.

- A. Except as specified in paragraph (C) of this section, a sink with at least three compartments shall be provided for manually washing, rinsing, and sanitizing equipment and utensils. Each compartment of the sink shall be supplied with hot and cold drinking running water.
- B. Sink compartments shall be self-draining and large enough to accommodate immersion of the largest equipment and utensils. If equipment or utensils are too large for the sink compartments, a warewashing machine or alternative equipment as specified in paragraph (C) of this section shall be used.
- C. Alternative manual warewashing equipment may be used when there are special cleaning needs or constraints and the Department has approved the use of the alternative equipment. Alternative manual warewashing equipment may include:
 - 1. High-pressure detergent sprayers;
 - 2. Low- or line-pressure spray detergent foamers;
 - 3. Other task-specific cleaning equipment;
 - 4. Brushes or other implements;
 - 5. Two-compartment sinks as specified in paragraph D of this section.
 - 6. Mechanical cleaning and sanitization as specified in Sections 4-404, 4-405 and 4-406.
- D. A two-compartment sink may be used in an existing retail food establishment only if:
 - 1. The Department has approved its use; and
 - 2. The nature of warewashing is limited to batch operations such as between cutting one type of raw meat and another or cleanup at the end of a shift, where the number of items cleaned is limited, and where the cleaning and sanitizing solutions are made up immediately before use and drained immediately after use. *If a detergent-sanitizer is used to sanitize in a cleaning and sanitizing procedure where there is not a distinct water rinse between the washing and sanitizing steps, then the detergent-sanitizer shall be approved and used according to the manufacturer's specifications.
 - 3. A two-compartment sink may not be used for warewashing operations such as where cleaning and sanitizing solutions are used for a continuous or intermittent flow of kitchenware or tableware in an ongoing warewashing process.
- E. In manual warewashing operations, a temperature measuring device shall be provided and readily accessible for frequently measuring the washing and sanitizing temperatures. The temperature of the wash solution shall be maintained at not less than 110°F (43°C)

unless a different temperature is specified on the cleaning agent manufacturer's label instructions.

- F. Equipment and utensils shall be pre-flushed or pre-scraped, and when necessary, pre-soaked to remove gross food particles and soil.
- G. When a three-compartment sink is utilized for warewashing or when equipment such as slicers, grinders, kettles, and mixers are cleaned and sanitized in place, the operation shall be conducted in the following sequence:
 - 1. The sinks or equipment used for warewashing shall be cleaned and sanitized before use; and
 - 2. Equipment and utensils shall be thoroughly cleaned in the first compartment with a clean detergent solution that is mixed in accordance with the manufacturer's label and a temperature of at least 110°F (43°F).
 - 3. Equipment and utensils shall be rinsed free of detergent and abrasive with clean water in the second compartment; and
 - *4. Equipment and utensils shall be sanitized in the third compartment according to one of the methods included in section 4-403 (I)(1-4).
- *H. When pressure spray methods are utilized for cleaning and sanitizing, the equipment and utensils shall be thoroughly flushed with a detergent-sanitizer solution until the article is free of food particles and soil. The detergent-sanitizer shall be used in accordance with the manufacturer's instructions and shall be of the type that does not require a potable water rinse when used according to those instructions.
- *I. The food-contact surfaces of all equipment and utensils shall be sanitized by:
 - 1. Immersion for at least ½ minute in clean, hot water of a temperature of at least 170°F (77°C); or
 - 2. Immersion for at least 1 minute in a clean solution containing a minimum of 50 parts per million (mg/L) and no more than 200 parts per million (mg/L) of available chlorine as a hypochlorite and having a temperature of at least 75°F (24°C); or
 - 3. Immersion for at least 1 minute in a clean solution containing at least 12.5 parts per million (mg/L) of available iodine, having a pH range not higher than 5.0, unless otherwise certified to be effective by the manufacturer, and at a temperature of at least 68°F (20°C); or
 - 4. Immersion in a clean solution containing a quaternary ammonia product at a minimum of 75°F (24°C) or any other chemical sanitizing agent allowed under Sanitizers, 40 CFR 180.940 (2005).
 - 5. Treatment with steam that is free from materials or additives other than those specified in 21 CFR section 173.310, (2003) in the case of equipment too large to sanitize by immersion, but in which steam can be confined; or
 - 6. Rinsing, spraying, or swabbing with a chemical sanitizing solution containing at least the strength required for that particular sanitizing solution in section 4-403(I)(2-4) for equipment too large to sanitize by immersion.
 - 7. If a chemical not specified in paragraphs (2)-(4) of this section is used, the licensee shall demonstrate to the Department that the solution achieves sanitization and the use of the solution shall be approved; or

8. If a chemical sanitizer other than chlorine, iodine, or a quaternary ammonium compound is used, it shall be registered with EPA and applied in accordance with the EPA registered label use instructions.
- *J. When hot water is used for sanitizing, the following equipment shall be provided and used:
1. An integral heating device or fixture installed in, on, or under the sanitizing compartment of the sink which is capable of maintaining the water at a temperature of at least 170°F (77°C); and
 2. A numerically-scaled indicating temperature measuring device, accurate to $\pm 3^{\circ}\text{F}$ ($\pm 2^{\circ}\text{C}$), located convenient to the sink for frequent checks of water temperature; and
 3. Utensil racks, baskets, or other appropriate means to permit complete immersion of utensils and equipment in the hot water.
- *K. Chemicals used for sanitization, shall not have concentrations higher than the maximum permitted under Sanitizers, 40 CFR 180.940 (2005).

4-404 Mechanical Cleaning and Sanitization

- A. Cleaning and sanitizing may be done by spray-type, immersion warewashing, or by any other type of machine or device if it is demonstrated that it thoroughly cleans and sanitizes equipment and utensils. These machines and devices shall be properly installed and maintained in good repair. Machines and devices shall be operated in accordance with manufacturer's instructions. Utensils and equipment placed in the machine shall be exposed to all warewashing cycles. Automatic detergent dispensers, wetting agent dispensers, and liquid sanitizer injectors shall be properly installed and maintained.
- B. The pressure of final rinse water supplied to spray-type warewashing machines shall not be less than 15 pounds per square inch (1.05 kg per sq cm) nor more than 25 pounds per square inch (1.76 kg per sq cm) measured in the water line immediately upstream from the final rinse control valve. A 1/4 inch (6.4 millimeters) Iron Pipe Size (IPS) valve shall be provided immediately upstream from the final control valve to permit checking the flow pressure of the final rinse water. In all new installations, a pressure gauge shall be provided for use with the IPS valve. This section does not apply to a machine that uses only a pumped sanitizing rinse.
- C. Machine or water-line mounted numerically-scaled indicating temperature monitoring device, accurate to $\pm 3^{\circ}\text{F}$ ($\pm 2^{\circ}\text{C}$), shall be provided to indicate the temperature of the water in each tank of the machine and the temperature of the final rinse water as it enters the manifold.
- D. Rinse water tanks shall be protected by baffles, curtains, or other effective means to minimize the entry of wash water into the rinse water. Conveyors in warewashing machines shall be accurately timed to ensure proper exposure times in wash and rinse cycles in accordance with manufacturer's specifications attached to the machines.
- E. Equipment and utensils shall be flushed or scraped and, when necessary, soaked to remove gross food particles and soil prior to being washed in a warewashing machine unless a pre-wash cycle is a part of the warewashing machine operation. Equipment and utensils shall be placed in racks, trays, or baskets, or on conveyors, in a way that exposes food-contact surfaces to the unobstructed application of detergent wash and clean rinse waters, and that permits free draining.

- F. Chemical sanitizing warewashing machines (single-tank, stationary-tank, door-type machines, and spray-type glass washers) may be used provided that:
1. The temperature of the wash water shall not be less than 120°F (49°C);
 2. The wash water shall be kept clean; and
 3. Chemicals added for washing and sanitization purposes shall be automatically dispensed; and
 - *4. Utensils and equipment shall be exposed to the final chemical sanitizing rinse in accordance with the manufacturer's specifications for time and concentration; and
 - *5. The chemical sanitizing rinse water temperature shall not be less than 75°F (24°C) nor less than the temperature specified by the machine's manufacturer; and
 - *6. Chemical sanitizers shall meet the requirements specified 40 CFR 180.940 (2005) and be applied in accordance with the EPA registered label use instructions.
- *G. Hot water sanitizing warewashing machines may be used, provided that wash water and pumped rinse water is kept clean and the wash solution temperature is maintained at not less than the temperatures stated in this section 4-404(G)(1-5).
- Achieving a utensil and/or equipment surface temperature of 160°F (71°C) is an acceptable means of testing the sanitization process of a hot water sanitizing warewashing machine.
1. Single-tank, stationary-rack, dual-temperature machines:
Wash temperature 150°F (66°C)
 2. Single-tank, stationary-rack, single-temperature machine:
Wash temperature 165°F (74°C)
 3. Single-tank, conveyor machine:
Wash temperature 160°F (72°C)
 4. Multi-tank, conveyor machine:
Wash temperature 150°F (66°C)
Pumped rinse temperature 160°F (72°C)
 5. Single-tank, pot, pan, and utensil washer (either stationary or moving rack):
Wash temperature 140°F (60°C)
- *H. Mechanical Warewashing Equipment, Hot Water Sanitization Temperatures
- In mechanical warewashing machines the temperature of the fresh hot water sanitizing rinse as it enters the manifold may not be more than 194°F (90°C), or less than:
1. For a stationary rack, single temperature machine, 165°F (74°C); or
 2. For all other machines 180°F (82°C).
- I. All warewashing machines shall be thoroughly cleaned daily and as needed to maintain them in a satisfactory operating condition.

- J. A warewashing machine shall be provided with an easily accessible and readable data plate affixed to the machine which includes:
 - 1. Temperatures required for washing, rinsing, and sanitizing;
 - 2. Pressure required for the fresh water sanitizing rinse unless the machine is designed to use only a pumped sanitizing rinse;
 - 3. Conveyor speed required for conveyor machines or cycle time required for stationary-rack machines; and
 - 4. Required type and concentration of sanitizing solutions.
- K. After being cleaned and sanitized, equipment and utensils shall not be rinsed before air drying or use unless:
 - 1. The rinse is applied directly from a drinking water supply by a warewashing machine that is maintained and operated as specified in sections 4-404; and
 - 2. The rinse is applied only after the equipment and utensils have been sanitized by the application of hot water or by the application of a chemical sanitizer solution whose EPA registered label use instructions call for rinsing off the sanitizer after it is applied in a commercial warewashing machine.

4-405 Drainboard and Dishtable Requirements

- A. Drainboards and dishtables shall be self draining and shall have a minimum pitch of 1/8 inch (3.2mm) per foot (304.8mm). Drainage shall be directed to warewashing sink bowls, pre-rinse sinks, scuppers or warewashing machines.
- B. Drainboards and dishtables shall be supported as needed to prevent sagging and shall have edges turned up at least ½ inch (12.7 mm).
- C. When provided on warewashing sinks, drainboards shall be integrally welded to the sink bowl(s).
- D. Drainboards and dishtables shall be large enough to accommodate for the staging of soiled equipment, dishes, glasses, mugs, kitchenware, tableware and utensils so they may be adequately pre-scraped and pre-flushed prior to warewashing and large enough to accommodate the air drying of sanitized items that may accumulate during hours of operation. Drainboard and dishtable’s length shall be measured from right to left.
 - 1. Drainboards and dishtables installed on the establishment’s primary means for warewashing shall be sized in accordance with the following:

FACILITY TYPE	SOILED DRAINBOARDS	CLEAN DRAINBOARDS
Single Service	Twenty-four (24) Inches (64 cm)	Twenty-four (24) Inches (64 cm)
Multi-use Service With Manual Warewashing	Thirty-six (36) Inches (91 cm)	Thirty-six (36) Inches (91 cm)
Multi-use Service With Mechanical Warewashing	Forty-eight (48) Inches (122 cm)	Forty-eight (48) Inches (122 cm)

2. Bar sinks shall be equipped with an eighteen (18") inch (46 cm) drainboard for staging soiled tableware, utensils, glasses and mugs and an eighteen (18") inch (46 cm) drainboard for air drying sanitized items.
 3. Under counter warewashing machines shall be provided with drainboards or dishtables that are large enough to accommodate staging of soiled equipment, dishes, glasses, mugs, kitchenware, tableware and utensils and large enough for air drying of sanitized items. A common drainboard, dishtable or the open door of the warewashing machine may be utilized.
 4. Multi-tank conveyor warewashing machines equipped with both, a powered pre-wash unit and a powered blower-dryer unit shall be equipped with dishtables sized in accordance with the warewashing machine's manufacture.
 5. Alternate equipment or methods, such as wall mounted drainboards, wire shelving or bus carts, may be provided for staging of soiled equipment, dishes, glasses, mugs, and utensils for pre-scraping and pre-flushing prior to warewashing and to accommodate air drying of sanitized items may be utilized if approved by the Department. Alternate equipment shall not be located or constructed in a manner that interferes with the proper use of the warewashing facilities.
- E. Except for under counter warewashing machines, prerinse sprayers or other approved means shall be provided and used for pre-scraping and pre-flushing of soiled equipment, dishes and utensils when a warewashing machine is installed.
- F. Scuppers when installed shall transverse the entire flat section of the drainboard or dishtable to prevent soiled water and debris from draining into the warewashing sink bowl or warewashing machine. Scuppers shall be equipped with a readily removable strainers or strainer baskets.

4-406 Drying

Unless used immediately after sanitization, all equipment and utensils shall be air-dried. Towel drying shall not be permitted. Utensils that have been air-dried may be polished with cloths which are maintained clean and dry.

4-407 Food-Contact Surfaces of Equipment and Utensils

- A. Equipment food-contact surfaces and utensils shall be clean to sight and touch.
- *B. Utensils and food-contact surfaces of equipment shall be cleaned and sanitized:
1. Before each use with a different type of raw animal food, such as beef, fish, lamb, pork, or poultry;
 2. Each time there is a change from working with raw animal foods to working with ready-to-eat foods;
 3. Between uses with raw fruits or vegetables and with potentially hazardous food (time/temperature control for safety food);
 4. At any time during the operation when contamination may have occurred; and
 5. After final use each working day.
- *C. Where equipment and utensils are used for the preparation of potentially hazardous food (time/temperature control for safety food) on a continuous or production-line basis,

utensils and the food-contact surfaces of equipment shall be cleaned and sanitized at intervals not to exceed four (4) hours.

- D. Surfaces of utensils and equipment contacting potentially hazardous food (time/temperature control for safety food) may be cleaned less frequently than every 4 hours if:
1. Utensils and equipment such as skillets, omelet pans and woks used on a production line basis in continuous use for the heating/cooking of potentially hazardous foods (time/temperature control for safety foods) shall be cleaned and sanitized after final use each working day and at least every 24 hours;
 2. Containers in serving situations such as salad bars, delis, and cafeteria lines holding ready to eat potentially hazardous food (time/temperature control for safety food) that is maintained at the temperature specified in chapter 3 and are intermittently combined with the additional supplies of the same food that is at the required temperature, and the containers are cleaned and sanitized at least every 24 hours;
 3. Utensils and equipment used to prepare food in a refrigerated room or area that is maintained at one of the temperatures in Figure 3 shall be cleaned and sanitized at the frequency that corresponds to the ambient temperatures:

<u>Temperature</u>	<u>Cleaning Frequency</u>
41°F (5.0°C) or less	24 hours
>41°F - 45°F (>5.0°C - 7.2°C)	20 hours
>45°F - 50°F (>7.2°C - 10.0°C)	16 hours
>50°F - 55°F (>10.0°C - 12.8°C)	10 hours

FIGURE 3

4. The food-contact surfaces of cooking and baking utensils and equipment, such as grills, woks, hot sandwich presses, waffle irons, as well as baking equipment and the cavities and door seals of microwave ovens shall be cleaned at least every 24 hours and shall be kept free of encrusted grease deposits and other accumulated soil. This shall not apply to hot-oil cooking equipment and hot-oil filtering systems.

4-408 Nonfood-Contact Surfaces

Nonfood-contact surfaces of equipment, including transport vehicles, shall be cleaned as often as necessary to keep the equipment free from the accumulation of dust, dirt, food particles, and other debris.

4-409 Dry Equipment Cleaning Methods

Dry equipment cleaning methods, such as brushing, scraping, and vacuuming shall contact only surfaces that are soiled with dry food residues that are not potentially hazardous; this cleaning equipment shall not be used for any other purpose.

4-5 LAUNDRY FACILITIES

4-501 Laundry Facilities

- A. If provided, laundry facilities shall be restricted to the washing and drying of linens and work clothes used in the operation. If such items are laundered on the premises, an electric or gas clothes dryer shall be provided and used, except that it is not necessary to provide a clothes dryer provided that:
 - 1. On-premise laundering is limited to wiping cloths intended to be used moist, and
 - 2. The laundered wiping cloths are stored in an approved sanitizing solution; or
 - 3. The laundered wiping cloths are air-dried in a laundry room or other approved locations.
- B. Laundry facilities shall not be located in food preparation areas. If located in food storage areas, it shall be operated in a manner that prevents the contamination of food, equipment, utensils, linens, single-service and single-use articles and wiping cloths.
- C. Soiled linens shall be kept in clean, nonabsorbent receptacles or clean, washable laundry bags. Soiled linens shall be stored and transported to prevent contamination of food, clean equipment, clean utensils, single-service and single-use articles.

4-6 EQUIPMENT AND UTENSIL HANDLING AND STORAGE

4-601 Equipment and Utensil Storage

- A. Cleaned and sanitized equipment and utensils shall be handled in a way that protects them from contamination. Spoons, knives, and forks shall be touched only by their handles. Cups, glasses, bowls, plates, and similar items shall be handled without contact with inside surfaces or surfaces that contact the user's mouth.
- B. Cleaned and sanitized utensils and equipment shall be stored at least 6 inches (15.24 cm) above the floor in a clean, dry location in a way that protects them from contamination by splash, dust, and other means. The food-contact surfaces of fixed equipment shall also be protected from contamination. Equipment and utensils shall not be placed under sewer lines or water lines that are not protected to intercept potential drips, including leaking automatic fire protection sprinkler heads, or under lines on which water has condensed.
- C. Utensils shall be air-dried, in accordance with section 4-406, before being stored or shall be stored in a self-draining position.
- D. Glasses and cups shall be stored inverted. Other stored tableware shall be covered or inverted, wherever practical. Facilities for the storage of knives, forks and spoons shall be designed and used to present the handle to the employee or consumer. Unless pre-wrapped, holders for knives, forks and spoons at self-service locations shall protect these articles from contamination and present the handle of the utensil to the consumer.

4-602 Single-Service and Single-Use Articles

- A. Single-service articles shall be stored at least 6 inches (15.24 cm) above the floor in closed cartons or containers which protect them from contamination. They shall not be placed under exposed sewer lines or water lines, except for automatic fire protection sprinkler heads that may be required by law.

- B. Single-service articles shall be handled and dispensed in a manner that prevents contamination of surfaces which may come in contact with food or with the mouth of the user.
- C. Single-service knives, forks, and spoons packaged in bulk shall be inserted into holders or be wrapped prior to dispensing by employees who have washed their hands immediately prior to sorting or wrapping the utensils. Holders shall be provided to protect these items from contamination and present the handle of the utensil to the consumer.
- D. Single-service and single-use articles may not be reused.
- E. Mollusk and crustacea shells may not be used more than once as serving containers.

4-603 Preset Tableware

Tableware may be preset if:

- A. Except as specified in paragraph (B) of this section, tableware that is preset shall be protected from contamination by being wrapped, covered or inverted;
- B. Preset tableware may be exposed if unused settings are removed when a consumer is seated and cleaned and sanitized before further use.

CHAPTER 5

WATER, PLUMBING, AND WASTE

5-1 WATER SUPPLY

*5-101 General

- A. Adequate, uncontaminated, safe drinking water for the needs of the retail food establishment shall be provided from a source constructed, maintained, and operated according to the *Colorado Primary Drinking Water Regulations* and regulations adopted pursuant to Title 25-1.5-203 C.R.S., or
1. If the retail food establishment does not meet the definition of a public water system pursuant to the *Colorado Primary Drinking Water Regulations*, promulgated pursuant to 25-1.5-101, and 25-1.5-203, C.R.S., the retail food establishment shall provide:
 - a. Adequate treatment on a continuous basis; and
 - b. Bacteriological samples at a minimum of once per quarter or at a frequency determined by the department; and
 - c. A DPD colorimetric drinking water test kit capable of testing free chlorine at an accuracy of 0.1 mg/liter; and
 - d. Free chlorine shall range from a trace amount to 4 mg/liter (0.2 to 1.2 mg/liter recommended) at any fixture; and
 - e. Most recent required water sample reports shall be retained on file at the retail food establishment and shall be available for review by the department when requested; and
 2. Retail food establishments with water supplies determined to be surface water or determined to be under the direct influence of surface water shall be required to filter their water to 1 μ m (micron) absolute using National Sanitation Foundation approved equipment and maintain a residual disinfectant concentration to ensure inactivation and/or removal of giardia and other parasitic cysts and viruses.

*5-102 System Flushing and Disinfection

A drinking water system shall be flushed and disinfected before being placed in service after construction, repair, or modification and after an emergency situation, such as a flood, that may introduce contaminants to the system.

*5-103 Bottled Drinking Water

Bottled drinking water used or sold in a retail food establishment shall be obtained from approved sources in accordance with Processing and Bottling of Bottled Drinking Water, 21 CFR section 129, (2009).

***5-104 Transportation**

All drinking water not provided directly by pipe to the retail food establishment from the source shall be transported in a bulk water transport system and shall be delivered to a closed-water system. Both of these systems shall be constructed and operated according to law and operated as approved by the Department.

***5-105 Emergency Alternative Water Supply**

- A. Establishments intending to operate when there is a temporary interruption of water service or an upset in the supply of treated drinking water, with approval by the Department prior to implementation, the establishment may continue operation if the temporary water supply meets the requirements of sections 5-101, 5-102, 5-103, 5-104 and 5-105 and drinking water is made available through:
1. A supply of commercially bottled drinking water;
 2. One or more closed portable water containers;
 3. An enclosed vehicular drinking water tank;
 4. An on-premises drinking water storage tank; or
 5. Piping, tubing, or hoses connected to an adjacent approved source.

***5-106 Non-Drinking Water**

A non-drinking water system is permitted for air conditioning, non-food equipment cooling, landscape irrigation and fire protection, and shall be installed according to law. Non-drinking water shall not directly or indirectly contact food or equipment or utensils that contact food. The piping of any non-drinking water system shall be identified so that it is readily distinguishable from piping that carries drinking water.

***5-107 Pressure and Temperature**

- A. Water under pressure of at least 15 pounds per square inch (psi) (1.05 kg per sq. cm) at the required temperature shall be provided to all fixtures and equipment that use water.
- B. Hot and cold water shall be provided to all sinks.

***5-108 Hot Water**

Hot water generation and distribution systems shall be sufficient to meet the peak hot water demands throughout the retail food establishment. (see Appendix C)

***5-108 Steam**

Steam used in contact with food or food-contact surfaces shall be free from any unsafe materials or additives not listed in Specific Usage Additives, 21 CFR section 173.310, (2003). (see Appendix D)

5-2 PLUMBING SYSTEM

5-201 General

Plumbing shall be sized, installed, and maintained in accordance with applicable state and local plumbing codes, ordinances, regulations, and standards. Plumbing shall be designed and constructed according to the 2009 International Plumbing Code. Where local building departments have adopted codes equivalent to or more stringent than the above, those codes shall apply. The Department shall work in collaboration with the local building and/or fire department with regard to enforcement and compliance activities. Plumbing fixtures shall be easily cleanable and kept clean.

*5-202 Backflow

*A. General

The drinking water system shall be constructed to prevent backflow. There shall be no unprotected cross-connections between the drinking water supply and any non-drinking water supply, or any sources of contamination. Devices or assemblies installed shall meet the appropriate application for the hazard of the cross connection to prevent backflow of a solid, liquid or gas contaminant into the drinking water supply system at each point of use within the retail food establishment.

*B. Backflow prevention devices and installation requirements

1. An air gap between the water supply inlet and the flood level rim of the plumbing fixture, equipment, or nonfood equipment shall be at least twice the diameter of the water supply inlet and may not be less than one (1) inch (25 mm).
2. An atmospheric vacuum breaker shall be located on the discharge side of the last valve and not less than six (6) inches (154.4 mm) above the flood rim of plumbing fixture or equipment. A shutoff valve downstream of the atmospheric vacuum breaker is prohibited.
3. Backsiphonage and backflow prevention devices shall meet American Society of Sanitary Engineering (A.S.S.E.) standards for construction, installation, maintenance, inspection and testing for that specific application and type of device.

C. Applications

- *1. Inlets to tanks, vats, garbage disposals, troughs, fixtures, warewashing machines and other equipment with submerged inlets shall be protected by an approved backflow prevention device or with an approved air gap at the inlet.

- *2. Carbonated Beverage Dispensers

The drinking water supply connection to carbonated beverage dispensers shall be protected against backflow by at least one of the following:

- a. An approved air gap; or
- b. A dual check valve constructed of a material not affected by carbon dioxide with an intermediate vent installed upstream of the carbonator and downstream of any copper and copper alloy piping or fixture; or
- c. A reduced pressure zone backflow prevention assembly constructed of material impervious to attack by carbon dioxide, and installed upstream

of the carbonator and downstream of any copper and copper alloy piping or fixture.

3. Non-Carbonated Beverage Dispensers

The drinking water supply connection to non-carbonated beverage dispensers shall be protected against backflow by at least one of the following:

- a. An approved air gap; or
- b. A dual check valve constructed of a material not affected by carbon dioxide with an intermediate vent installed downstream of any copper and copper alloy piping or fixture.

*4. Hose bibs, sillcocks, and threaded faucets where a hose can be attached shall be equipped with a proper backflow prevention device in accordance with 5-202 (B) (2) and (3). This paragraph shall not apply to water heater and boiler drain valves that are provided with hose connection threads and that are intended only for tank or vessel draining, or to water supply valves intended for connection of clothes washing machines where backflow prevention is otherwise provided or is integral with the machine.

5. In all new or extensively remodeled facilities, a dedicated hot and cold water supply shall be provided for chemical dispensing towers.

5-203 Conditioning Device, Design

Water filters, screens, and other water conditioning devices installed on water lines shall be made of safe materials and designed and located to facilitate disassembly for periodic servicing and cleaning. A water filter element shall be of the replaceable type.

5-204 Grease Trap / Grease Interceptor

If required by the local building, water or sanitation authority, when possible, a grease trap, grease interceptor, or solids interceptor should be located outside the establishment. When installed inside the establishment, a grease trap, grease interceptor, or solids interceptor shall be located away from the food preparation area and be easily accessible for cleaning.

5-205 Food Waste Grinders/Garbage Disposals

A. In new or extensively remodeled retail food establishments, food waste grinders or garbage disposals, if provided, shall be installed in the soiled drainboard of the warewashing sink, food preparation sink, or warewashing machine. The installation will be approved under the following conditions:

1. The disposal shall be directly connected to the sanitary sewer unless otherwise required by law; or
2. When installed in the drainboard of a food preparation sink, the drainboard shall be equipped with an indirectly drained scupper/scrap basket or similar device to prevent contamination of food-contact surfaces. A second approved eighteen inch (18") (46 cm) self-draining drain board or alternate approved methods shall be provided to prevent contamination of food.

B. Food waste grinders or garbage disposals may be installed in the basin of the sink if the sink is used solely for the disposal of food wastes.

***5-206 Drainage Of Equipment.**

- A. Warewashing machines, refrigerators, walk-in refrigerators, freezers, walk-in freezers, warewashing sinks, food/vegetable preparation sinks, steam kettles, potato peelers, ice bins, containers of ice for use in food and beverages, ice machines, and similar types of equipment in which food, portable equipment or utensils are placed shall be indirectly connected to the waste line and shall drain into an approved receptor of such size, shape, and capacity to prevent splashing or flooding. The receptor shall be readily accessible for cleaning and inspection.
- B. Warewashing sinks and dishmachines installed prior to the effective date of these Regulations may be directly connected to the plumbing waste system provided there is a floor drain or floor sink installed within five (5) feet (1.5 M) immediately downstream of the sink waste line, and the fixture shall be connected on the sewer side of the floor drain or floor sink, and no other fixtures are connected to the waste line. The fixture and floor drain shall be trapped and vented as required by the 2009 International Plumbing Code or where local building departments have adopted codes equivalent or more stringent than the above, those codes shall apply (see Figure 4).
- C. In new or extensively remodeled retail food establishments, each walk-in refrigerator used for iced products, hanging meats or which requires flushing shall either be equipped with a floor drain installed only with indirect waste and discharged through an air gap into an approved receptor or constructed so all parts of the floor of such walk-in refrigerator shall be graded to drain to the outside of the refrigerator through a waste pipe, doorway or other opening.

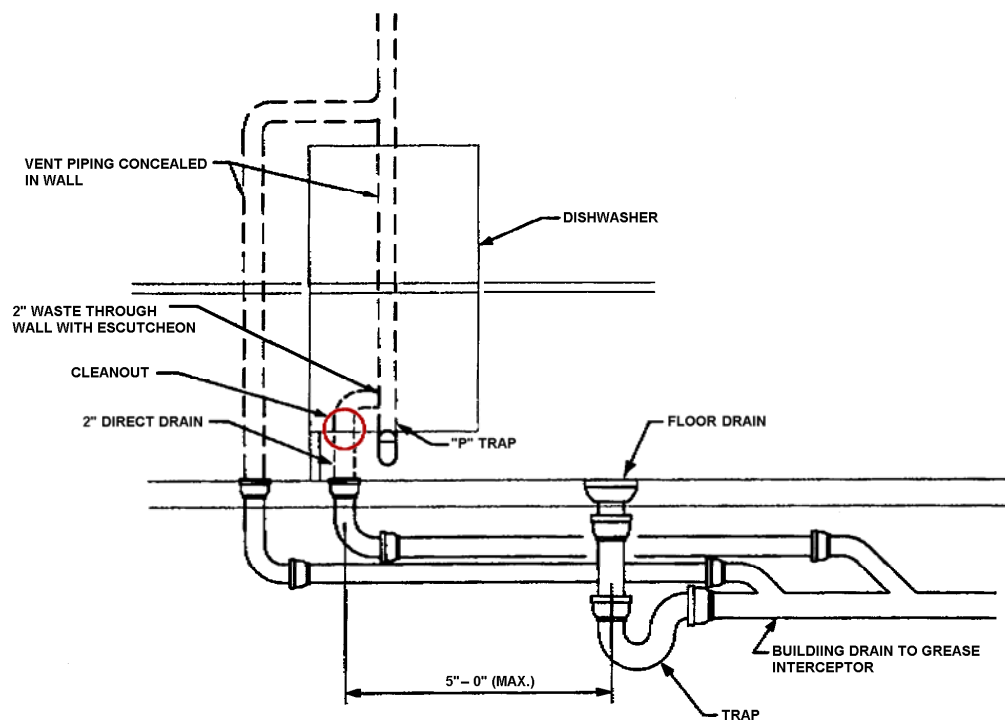

FIGURE 4

5-207 Drainage System Installation

Drain lines from equipment shall not discharge liquid waste in a manner that permits the flooding of floors, or the flowing of water across working or walking areas, or into difficult-to-clean areas that create a nuisance.

5-208 Handwashing Lavatory, Water Temperature, and Flow

- *A. The number of fixtures shall comply with the requirements of the plumbing code adopted by the respective local jurisdiction, or in the absence of such local requirements with the minimum plumbing fixtures listed in the 2009 International Plumbing Code.
- *B. Handsinks shall be conveniently located to employees involved in food preparation, food dispensing, warewashing and utensil handling. Handsinks shall be unobstructed and accessible to employees at all times and used only for handwashing. Sinks used for food preparation or for washing equipment shall not be used for handwashing. Handsinks used for toilet rooms shall be located in the toilet rooms.
- *C. Handwashing sink water temperatures. Each handsink shall be provided with water at least 100°F (38°C) by means of a mixing valve or combination faucet. Any self-closing, slow-closing, or metering faucet used shall be designed to provide a flow of water for at least 15 seconds without the need to reactivate the faucet.
- *D. A supply of hand-cleansing soap or detergent shall be available at each handsink or group of two (2) adjacent handwashing sinks. A continuous cloth towel system that supplies the user with a clean towel, individual disposable towels, or a hand-drying device providing heated or high velocity pressurized air shall be conveniently located near each handsink or group of adjacent handwashing sinks.
- *E. Common towels are prohibited for the drying of hands.
- F. Hand towels shall be stored to protect unused towels from becoming contaminated.
- G. If disposable towels are used, an easily cleanable waste receptacle shall be conveniently located near the handsink.
- H. Handsinks, soap dispensers, hand-drying devices and all related fixtures shall be kept clean and in good repair.
- I. Automatic Handwashing Facilities:
 - 1. If the model, installation, location, and conditions of use are approved, and the unit is capable of removing the types of soils encountered in the food operations involved, automatic handwashing facilities may be substituted for handwashing sinks in a food establishment that has at least one additional handwashing sink that is easily accessible.
 - 2. An automatic handwashing facility shall be installed and used in accordance with manufacturer's instructions.
- J. Handwashing Sink Specifications for New or Extensively Remodeled Establishments
 - 1. The height of the sink's flood rim shall be between 30 inches (76cm) and 48 inches (122 cm) above the floor.
 - 2. The diameter of the handwashing sink basin shall be a minimum of 10 inches (25 cm) in any direction.

3. When installed in a counter top, handwashing sink faucets shall be within 24 inches (61cm) of the front edge of the counter top.
4. The clearance between the flood rim of handwashing sink and the base or underside of any overhead cabinets, shelves, or other equipment shall be a minimum of 24 inches (61cm).
5. Handwashing sink faucets shall be installed on the side of the sink basin directly opposite the user.

5-209 Toilets and Urinals

- *A. Toilet facilities shall be installed according to law, shall be the number required by law, shall be conveniently located, and shall be accessible to employees and patrons.
- B. Separate toilet facilities shall be required for each sex in establishments with seating capacity in excess of 20 patrons or more than 20 employees. In all new or extensively remodeled retail food establishments, these facilities shall be installed to comply with the requirements of the Plumbing Code adopted by the respective local jurisdictions, or in the absence of such local requirements, with the minimum numbers of plumbing fixtures listed in the 2009 International Plumbing Code.
- C. Separate toilet facilities are not required for each sex in places of 15 or fewer seating capacity for patrons, or 20 or fewer employees where there is no seating capacity, provided the toilet is a single occupancy facility and the door can be secured from the inside.
- D. Retail food establishments with no space on the premises for consumption of food by patrons are required to provide toilet facilities only for employees. Patron facilities shall be available where parking is provided primarily for consumption of food on the premise. In all new or extensively remodeled retail food establishments where parking is provided primarily for consumption of food on the premise, the number of necessary fixtures shall comply with the minimum plumbing fixtures required by the Plumbing Code or Building Code adopted by the respective local jurisdiction, or in the absence of such local requirements, with the numbers listed in 2009 International Plumbing Code, table 403.1.
- E. Employees and patrons may use the same toilet facility provided that patrons have access to them without entering the food preparation, food storage, or warewashing or utensil storage areas of the establishment.
- F. Public toilets in multiple activity areas such as shopping centers, sports centers, etc., may suffice for the use of retail food establishment patrons and employees, if fixtures are provided in adequate numbers conveniently located to the retail food establishment and available at all times the retail food establishment is in operation.
- G. Except where a toilet room is located outside a food establishment and does not open directly into the food establishment such as a toilet room that is provided by the management of a shopping mall, a toilet room located on the premises shall be completely enclosed and provided with a tight-fitting and self-closing door.
- H. Toilet facilities, including toilet fixtures and any related vestibules, shall be kept clean and in good repair. A supply of toilet tissue in a permanently mounted dispenser shall be provided at each toilet at all times.
- I. Easily cleanable trash receptacles shall be provided. A toilet room used by females shall be provided with a covered trash receptacle for sanitary products. Trash receptacles shall

be emptied at least once a day, and more frequently when necessary to prevent excessive accumulation of refuse.

5-210 Utility Facility

- A. In new or extensively remodeled retail food establishments, at least one conveniently located utility sink or curbed cleaning facility with a floor drain and hot and cold water shall be provided and used for the cleaning of mops or similar wet floor cleaning tools and for the disposal of mop water or similar liquid wastes.
- B. Suitable cleaning equipment and supplies, such as high pressure pumps, hot water, steam, and detergent, shall be provided as necessary for effective cleaning of equipment and receptacles for refuse, recyclables, and returnables. If approved by the Department, off-premise cleaning services may be used.
- *C. A utility sink cannot be used for food preparation or warewashing.
- D. **Dump Sinks**
In new or extensively remodeled establishments, bars, juice bars, coffee bars, drink stations, wait stations or other areas where soiled drinking glasses and mugs are emptied and staged for warewashing, a dump sink shall be provided and used for the sanitary disposal of liquid drink waste, ice and/or collection of debris emptied from glasses and mugs.
 - 1. Dump sinks shall be fitted with a removable strainer basket, and shall be plumbed with hot and cold running water.
 - 2. Blender station sinks and food preparation sinks shall not be utilized as dump sinks.
 - 3. Other methods may be used if approved by the Department.

***5-211 Sewage**

All sewage shall be disposed of by a sewage disposal system constructed, maintained and operated according to law.

***5-212 Water Reservoir of Fogging Devices, Cleaning**

- A. A reservoir used to supply water to a device, such as a produce fogger shall be:
 - 1. Installed and maintained in accordance with manufacturer's specifications; and
 - 2. Cleaned in accordance with manufacturer's specifications or according to the procedures specified in paragraph B of this section, whichever is more stringent.
- B. Cleaning procedures shall include at least the following steps and shall be conducted at least once a week:
 - 1. Draining and complete disassembly of the water and aerosol contact parts;
 - 2. Brush-cleaning the reservoir, aerosol tubing, and discharge nozzles with a suitable detergent solution;
 - 3. Flushing the complete system with water to remove the detergent solution and particulate accumulation; and
 - 4. Rinsing by immersing, spraying, or swabbing the reservoir, aerosol tubing, and discharge nozzles with at least 50 ppm (mg/L) hypochlorite solution.

5-3 REFUSE, RECYCLABLES, AND RETURNABLES

5-301 Containers

- A. Garbage, refuse, compost, and recyclables shall be held in durable, easily cleanable containers that do not leak and do not absorb liquids. Plastic bags and/or wet strength paper bags shall be used to line these containers. Such bags and durable plastic garbage and refuse containers shall be used for storage inside the food establishment.
- B. Containers stored in food preparation and utensil washing areas shall be emptied when full.
- C. Containers stored outside the food establishment, including dumpsters, compactors, and compactor systems, shall be easily cleanable, shall be insect and rodent-proof, shall be provided with tight-fitting lids, doors, or covers, and shall be kept covered when not in actual use. Drains in receptacles and waste handling units for refuse, recyclables and returnables shall have drain plugs in place.
- D. There shall be a sufficient number of containers to hold all the garbage, refuse, compost and recyclables that accumulate.
- E. Soiled containers, including dumpsters, compactors, and compactor systems, shall be cleaned at a frequency to prevent insect and rodent attraction. Each container shall be thoroughly cleaned on the inside and outside in a way that does not contaminate food, equipment, utensils, or food preparation areas. Suitable facilities, detergent, and hot water or steam, shall be provided and used for cleaning containers. Liquid waste from compacting or cleaning operations shall be disposed of as sewage.

5-302 Storage

- A. Garbage, refuse, compost and recyclables, on the premises, shall be stored in a manner to be inaccessible to insects and rodents. Cardboard or other packaging material not containing garbage or food wastes need not be stored in covered containers provided such materials do not create a nuisance.
- B. Indoor garbage or refuse storage rooms, compost and recycling areas if provided, shall be constructed of easily cleanable, nonabsorbent, washable materials, shall be kept clean, and shall be insect and rodent resistant. These areas shall be large enough to store all garbage and refuse containers.
- C. Outside storage areas or enclosures, if provided, shall be kept clean and shall be large enough to store all the garbage and refuse containers. Garbage, refuse, compost, recycling containers, dumpsters, and compactor systems located outside, shall be stored on a smooth surface of nonabsorbent material, such as concrete or machine-laid asphalt, that is kept clean and maintained in good repair.

5-303 Disposal

- A. Garbage, refuse, compost and recyclable materials shall be removed often enough to prevent the development of objectionable odors and the attraction of insects and rodents.
- B. Where garbage or refuse is burned on the premises, it shall be done by controlled incineration in accordance with the law. Areas around incineration units shall be kept clean and orderly.

5-304 Storage Areas, Redeeming Machines, Equipment, and Receptacles, Location

- A. An area designated for refuse, recyclables, compost, returnables and, a redeeming machine for recyclables or returnables, except as specified in paragraph B of this section, shall be located separate from food, equipment, utensils, linens, and single-service and single-use articles, and a public health nuisance is not created.
- B. A redeeming machine may be located in the packaged food storage area or consumer area of a retail food establishment if food, equipment, utensils, linens, and single-service and single-use articles are not subject to contamination from the machines and a public health nuisance is not created.
- C. The location of equipment and receptacles for refuse, recyclables, compost and returnables may not create a public health nuisance or interfere with the cleaning of adjacent space.

CHAPTER 6

PHYSICAL FACILITIES

6-1 FLOORS

6-101 Floor Construction

- A. Floors and floor coverings in all food preparation, food storage, warewashing areas, walk-in refrigeration units, dressing rooms, locker rooms, utility sink areas, toilet rooms, garbage rooms, and around permanently installed buffets, salad bars and soft drink dispensers shall be constructed of smooth, durable, nonabsorbent and easily cleanable material and shall be maintained in good repair. Areas subject to spilling or dripping of grease or fatty substances shall be of grease-resistant material. Nothing in this section shall prohibit the use of anti-slip floor coverings in areas where necessary for safety reasons.
- B. Floors which are water flushed or which receive discharges of water or other fluid wastes or are in areas where pressure spray methods for cleaning are used, shall be provided with properly installed trapped drains and graded to drain. In all new establishments, floor drains and floor sinks shall be installed to be accessible for cleaning.

6-102 Floor Carpeting

Carpeting, if used as a floor covering, shall be of closely-woven construction, properly installed, easily cleanable, and maintained in good repair. Carpeting shall not be used in food preparation, warewashing, food storage, utility sink areas, or in toilet room areas where urinals or fixtures are located. Carpeting is permitted in the retail sales area provided it is maintained in good repair and kept clean.

6-103 Utility Line Installation

Exposed utility service lines and pipes shall be installed in a way that does not obstruct or prevent cleaning of the floor. In all new or extensively remodeled food establishments, installation of exposed horizontal utility service lines and pipes on the floor is prohibited.

6-104 Floor Junctures

All floors installed in food preparation, food storage and warewashing areas, and in walk-in refrigerators, dressing or locker rooms, utility sink areas, and toilet rooms, shall provide a coved juncture between the floor and wall. In all cases, the juncture between the floor and wall shall be closed and sealed.

6-105 Prohibited Floor Covering

Cardboard, newspapers, sawdust, wood shavings, granular salt, baked clay, diatomaceous earth, or similar materials shall not be used as floor coverings; however, these materials may be used in amounts necessary for immediate spot clean-up of spills or drippage on floors.

6-106 Mats and Duckboards

Mats and duckboards shall be designed to be removable, easily cleanable, and be maintained clean and in good repair.

6-2 WALLS AND CEILINGS

6-201 Construction

- A. Walls, wall coverings, and ceilings shall be designed, constructed and installed to be smooth, durable and easily cleanable.
- B. Except for in dry storage units, walls, including non-supporting partitions, wall coverings and ceilings of walk-in refrigerating units, food preparation areas, food storage areas, equipment-washing and warewashing areas shall be smooth, nonabsorbent, easily cleanable, and maintained in good repair. Concrete or pumice blocks used for interior wall construction in these locations shall be finished and sealed to provide an easily cleanable surface. Acoustical material, free of porous perforations, smooth and durable enough to be washed with a cloth or sponge, may be used. Walls, including non-supporting partitions and wall coverings in toilet rooms shall be smooth, nonabsorbent, and easily cleanable. Porous acoustical ceilings are permitted in toilet rooms and their vestibules.

6-202 Attachments, Exposed Construction

- A. Except as specified in paragraph C of this section, attachments to walls and ceilings such as light fixtures, mechanical room ventilation system components, vent covers, wall-mounted fans, decorative items, and other attachments shall be easily cleanable.
- B. Studs, joists, and rafters shall not be exposed in those areas listed in section 6-201(B) of these rules and regulations. If exposed in other rooms or areas, they shall be kept clean.
- C. In consumer and backbar areas limited to beverage service and the heating of pre-prepared foods for immediate service, wall and ceiling surfaces and decorative items and attachments that are provided for ambiance need not meet this requirement if they are kept clean.
- D. Exposed utility service lines and pipes shall not obstruct or prevent cleaning of walls and ceilings. Utility service lines or pipes shall not be unnecessarily exposed on walls or ceilings in those areas listed in section 6-201(B) of these rules and regulations.

6-3 LIGHTING

6-301 Light Intensity

- A. Permanently fixed artificial light sources shall be installed to provide at least 50 foot candles (540 lux) of light on all food preparation surfaces and at warewashing work levels.
- B. Permanently fixed artificial light sources shall be installed to provide, at a distance of 30 inches (76 cm) from the floor:
 - 1. At least 20 foot candles (215 lux) of light in sales areas, at consumer service areas such as buffets and salad bars, utensil and equipment storage areas, and in lavatory and toilet areas; and
 - 2. At least 10 foot candles (108 lux) of light throughout walk-in refrigeration and freezer units, dry food storage areas, and in all other areas.

6-302 Light Bulbs, Protective Shielding

- A. Except as specified in paragraph B of this section, light bulbs shall be shielded, coated, or otherwise shatter-resistant in areas where there is exposed food, clean equipment, utensils, linens, or unwrapped single-service and single-use articles.
- B. Shielded, coated or otherwise shatter-resistant bulbs are not required in areas used only for storing food in unopened packages if:
 - 1. The integrity of the packages cannot be affected by broken glass falling onto them; and
 - 2. The packages are capable of being cleaned of debris from broken bulbs before the packages are opened.
- C. An infrared or other heat lamp shall be protected against breakage by a shield surrounding and extending beyond the bulb so that only the face of the bulb is exposed.

6-4 OPERATION AND MAINTENANCE

6-401 Cleaning Physical Facilities

- A. Cleaning of floors, walls, and ceilings shall be done as needed, preferably during periods when the least amount of food is exposed, such as after closing.
- B. Only dustless methods for cleaning floors, walls, and ceilings shall be used, such as vacuum cleaning, wet cleaning, treated dust mops, or the use of dust-arresting sweeping compounds with brooms.
- C. Floors, mats, duckboards, walls, ceilings, and attachments (e.g., light fixtures, vent covers, wall and ceiling mounted fans, and similar equipment), and decorative materials (e.g., signs and advertising materials), shall be kept clean.
- D. Mop water shall be changed as needed to prevent the recontamination of cleaned surfaces.

6-402 Cleaning Equipment Storage.

Maintenance and cleaning tools, such as brooms, mops, vacuum cleaners, and similar equipment, shall be maintained in good repair and stored in a way that does not contaminate food, utensils, equipment, or linens. Maintenance and cleaning tools shall be stored in an orderly manner to facilitate the cleaning of the storage area. After use, mops shall be placed in a position that allows them to air-dry without soiling walls, equipment, or supplies.

6-5 PREMISES

6-501 General

- A. Retail food establishments and all parts of the property used in connection with operations of the retail food establishment shall be kept free of litter, maintained clean and in good repair, and shall comply with local ordinances.
- B. The outdoor walking and driving areas shall be surfaced with concrete, asphalt, gravel or other materials that have been effectively treated to minimize dust, facilitate maintenance, and minimize muddy conditions. These surfaces shall be graded to drain

and kept free of litter. Exterior surfaces of buildings shall be of weather-resistant materials and shall comply with law.

- C. Only articles necessary to the operation and maintenance of the retail food establishment shall be stored on the premises.

6-502 Living Areas

No retail food establishment operation shall be conducted in any area used as living or sleeping quarters. A retail food establishment operation shall be separated from any living or sleeping quarters by complete partitioning and solid, self-closing doors, and shall comply with local requirements.

6-503 Dressing Rooms and Locker Areas

- A. Dressing rooms or dressing areas shall be designated if employees routinely change their clothes in the establishment.
- B. Designated areas or other suitable facilities shall be provided for the orderly storage of employees' clothing and other possessions.
- C. If the retail food establishment provides a storage area for any food belonging to employees it shall be inside a covered, leakproof container designated for the storage of employee food and maintained by the facility.

CHAPTER 7

POISONOUS OR TOXIC MATERIALS

7-1 LABELING AND IDENTIFICATION

*7-101 Identifying Information, Prominence

Containers of poisonous or toxic materials and personal care items shall bear a legible manufacturer's label.

*7-102 Working Containers

Working containers used for storing poisonous or toxic material, such as cleaners and sanitizers taken from bulk supplies, shall be clearly and individually identified with at least the name of the material.

*7-103 Separation

Poisonous or toxic materials shall be stored so they do not contaminate food, equipment, utensils, linens, or single-service and single-use articles by:

- A. Separating the poisonous or toxic materials by spacing or partitioning; and
- B. Locating the poisonous or toxic materials in an area that is not above food, equipment, utensils, linens, and single-service or single-use articles. Except that equipment and utensil cleaners and sanitizers may be stored in warewashing areas for availability and convenience if such materials are stored to prevent contamination of food, equipment, utensils, linens, or single-service and single-use articles.
- C. Poisonous or toxic materials stored or displayed for retail sale shall be separated from food and single-service articles by spacing, partitioning, or dividers. These materials shall not be stored or displayed above food or single-service articles.

*7-104 Restriction

- A. Only those poisonous or toxic materials required for the operation and maintenance of a retail food establishment, such as for the cleaning and sanitizing of equipment and utensils and the control of insects and rodents, shall be allowed in a retail food establishment.
- B. Paragraph A of this section does not apply to packaged poisonous or toxic materials that are for retail sale.

*7-105 Use of Materials

- A. Sanitizers, disinfectants, cleaning compounds, or other compounds intended for use on food-contact surfaces shall not be used in a way that leaves a toxic residue on such surfaces in accordance with 40 CFR 180.940 (2005).
- B. Poisonous or toxic materials shall not be used in a way that contaminates food, food contact surfaces, equipment, utensils, or single service articles, nor in a way other than in full compliance with the manufacturer's labeling.

***7-106 Food Containers**

A container previously used to store poisonous or toxic materials shall not be used as a food contact surface. A container previously used to store food shall not be used as a container to store toxic materials.

***7-107 Chemicals for Washing Fruits and Vegetables, Criteria**

Chemicals used to wash whole fruits and vegetables shall meet the requirements of Chemicals Used In Washing Or To Assist In The Lye Peeling Of Fruits And Vegetables, 21 CFR section 173.315, (2003).

***7-108 Boiler Water Additives, Criteria**

Chemicals used as boiler water additives shall meet the requirements specified in Boiler Water Additives, 21 CFR section 173.310, (2003) (see Appendix D).

***7-109 Drying Agents, Criteria**

Drying agents used in conjunction with sanitization shall be approved by the Department.

***7-110 Personal Medications**

Only those medications necessary for the health of employees shall be present in the retail food establishment. Medications and cosmetics shall be stored in properly labeled containers and located so that food and food-contact surfaces of equipment, utensils, linens, single-service and single-use articles cannot be contaminated. Medications requiring refrigeration and stored in a food refrigerator shall be properly identified, double packaged and located on the lowest shelf. This paragraph does not apply to medications that are stored or displayed for retail sale.

***7-111 First Aid Supplies**

First aid supplies shall be properly labeled and stored in a way that prevents them from contaminating food and food-contact surfaces, equipment, utensils, linens, single-service and single-use articles.

CHAPTER 8

INSECT, RODENT AND ANIMAL CONTROL

8-1 PREVENTION

8-101 Outer Openings, Protected

- A. Openings to the outdoors shall be protected against the entry of insects and rodents by:
 - 1. Closed, tight-fitting windows; and
 - 2. Solid self-closing, tight-fitting doors; or
- B. If windows or doors are kept open, the openings shall be protected against the entry of insects and rodents by:
 - 1. 16 mesh to 1 inch (16 mesh to 25.4 mm) screens,
 - 2. Properly designed and installed air curtains to control flying insects, or
 - 3. Other effective means.
- C. Paragraph B of this section does not apply in customer areas if flying insects and other pests are absent due to the location of the retail food establishment, the weather, or other limiting conditions.
- D. Doors used only for delivery or emergency exit are not required to be equipped with self-closing devices, but shall remain closed at all other times.
- E. All foundations shall be rodent-proof. Openings between the floor and bottom of outer doors, when closed, shall be no greater than one-fourth inch (1/4") (0.635 cm).

8-102 Controlling Pests

The presence of insects, rodents, and other pests shall be controlled to minimize their presence on the premises by:

- A. Routinely inspecting incoming shipments of food and supplies;
- B. Routinely inspecting the premises for evidence of pests;
- *C. Using methods, if pests are found, such as trapping devices or other means of pest control as specified in sections 8-103 and 8-104;
- D. Eliminating harborage conditions; and
- E. Eliminating infestations.

8-103 Insect Control Devices, Design and Installation

- A. Devices used to electrocute flying insects and that may impel insects or insect fragments shall be:
 - 1. Designed to have escape-resistant trays; and
 - *2. Installed so that:
 - a. The devices are not located over a food preparation area; and

- b. Dead insects and insect fragments are prevented from falling on or being impelled onto exposed food, clean equipment, utensils, linens, and unwrapped single-service and single-use articles.
- *B. Devices used to trap insects by adherence may not be installed above exposed food, clean equipment, utensils, linens, or unwrapped single-service and single-use articles unless the device is designed to completely contain the trapped insects.

***8-104 Pesticide Application**

- A. Only pesticides registered for application in a food establishment are permitted and shall be applied according to label directions.
- B. A pesticide shall be applied so that direct or indirect contact with food, equipment, utensils, linens, and single-service and single-use articles is prevented by protecting those items as follows:
 - 1. Removing the items;
 - 2. Covering the items with impermeable covers; or
 - 3. Taking other appropriate preventive actions; and
 - 4. Cleaning and sanitizing equipment and utensils after the application of a pesticide.
- C. Bait shall be contained in a covered tamper-proof bait station.
- D. Only nontoxic tracking powder such as talcum or flour may be used provided it does not contaminate food, equipment, utensils, linens, single-service or single-use articles.

***8-105 Removing Birds, Insects, Rodents, and Other Pests**

Birds, insects, rodents, and other pests shall be removed from control devices and the premises at a frequency that prevents their accumulation, decomposition, or the attraction of pests.

***8-106 Prohibiting of Animals**

- *A. Except as specified in (B) and (C) of this section, live animals may not be allowed on the premises of a food establishment.
- B. Provided that the contamination of food; clean equipment, utensils, and linens; and unwrapped single-service and single-use articles is controlled, live animals are allowed in the following situations:
 - 1. Edible fish or decorative fish in aquariums, shellfish or crustacea on ice or under refrigeration, and shellfish and crustacea in display tank systems;
 - 2. Patrol dogs accompanying police or security officers in offices and dining, sales, and storage areas, and sentry dogs running loose in outside fenced areas;
 - 3. In areas that are not used for food preparation and that are usually open for customers, such as dining and sales areas, service animals that are controlled by the disabled employee or person. This does not apply to incidental food contact surfaces including dining tables, grocery carts and baskets;
 - 4. Pets in the common dining areas of institutional care facilities such as nursing homes, assisted living facilities, group homes, or residential care facilities at times other than during meals if:

- a. Effective partitioning and self-closing doors separate the common dining areas from food storage or food preparation areas;
 - b. Condiments, equipment, and utensils are stored in enclosed cabinets or removed from the common dining areas when pets are present; and
 - c. Dining areas including tables, countertops, and similar surfaces are effectively cleaned before the next meal service; and
5. In areas that are not used for food preparation, storage, sales, display, or dining, in which there are caged animals or animals that are similarly confined, such as in a variety store that sells pets or a tourist park that displays animals.
- C. Live fish bait shall be stored to prevent contamination of food; clean equipment, utensils, and linens; and unwrapped single-service and single-use articles.

CHAPTER 9

MOBILE RETAIL FOOD ESTABLISHMENTS OR PUSHCARTS

9-1 MOBILE RETAIL FOOD ESTABLISHMENT

9-101 General

- A. Mobile retail food establishments and pushcarts shall comply with the requirements of these rules and regulations except as otherwise provided in this chapter. The Department may impose additional requirements to protect against health hazards related to the conduct of the mobile retail food establishment or pushcart and may prohibit the sale of any potentially hazardous foods (time/temperature control for safety foods). This may include maintaining receipts, logs, or any other records. If restrictions are imposed by the Department, they shall be in writing with a copy provided on the mobile unit at all times. A list of menu items prepared and/or served by the operator shall be submitted to the Department and available at all times. The original retail food establishment license shall be posted on the unit at all times as per Section 11-101.

When no apparent health hazard will result, the Department may waive or modify requirements of these rules and regulations relating to physical facilities, except those requirements of sections 9-104 and 9-105.

- B. Mobile Retail Food Establishments shall have equipment installed and/or mounted, according to Section 4-302, within the mobile retail food establishment with the exception of a grill and/or a smoker, approved by the Department, which shall be allowed outside of the mobile retail food establishment for cooking of food only. *All foods shall be prepared, assembled and served from within the mobile retail food establishment and not from the external piece of cooking equipment.
- C. Pushcarts shall be limited to cooking approved menu items and serving commercially prepared or commissary prepared food that will result in simple assembly. All items related to the operation of the pushcart shall be kept on the unit, except for those items specified in Section 9-108(A).

9-102 Exemptions

Mobile retail food establishments and pushcarts are exempt from requirements for self-contained water or sewage systems, and cleaning and sanitization of equipment under the following conditions:

- A. The menu is limited to commercially packaged potentially hazardous foods (time/temperature control for safety foods) or food that is prepared, then packaged in individual servings, transported and stored and served without further handling under conditions meeting the requirements of these rules and regulations; and
- B. Beverages served are dispensed from covered urns or other protected equipment; and
- C. The required equipment for cleaning and sanitization exists at the commissary.

9-103 Single-service Articles

Mobile retail food establishments and pushcarts shall provide only single-service articles for use by the consumer.

9-104 Water System

- *A. A mobile retail food establishment or a pushcart that does not meet the exemptions of section 9-102 of these rules and regulations shall provide hot and cold drinking water under pressure with sufficient capacity for food preparation, utensil cleaning and sanitizing, in accordance with the requirements of these rules and regulations.
- B. The water supply tank shall be designed so that it can be flushed and with a drain that permits complete drainage of the tank. The drinking water tank shall have no common interior partition with the tank holding non-potable water or other liquids. The water tank overflow or vent shall terminate in a downward direction and shall be located and constructed so as to prevent the entrance of contaminants.
- *C. When a mobile retail food establishment or pushcart is equipped with a three-compartment warewashing sink, the water supply shall be sized to adequately fill warewashing sinks at least once every four (4) hours of operation. In addition, the mobile retail food establishment or pushcart must supply three (3) gallons of water to each hand washing sink for each hour of operation. Where other water using fixtures such as toilets, utility sinks, food preparation sinks, coffee, espresso and soft drink machines are provided, the water supply shall be sized in accordance with the manufacturer's specification for each fixture.
- *D. The water supply tank for push carts shall have a minimum capacity of at least five (5) gallons.
- *E. Adequate water pressure must be provided at all fixtures at all times. A minimum flow rate of one (1) gallon per minute or thirty-two (32) ounces per fifteen (15) seconds shall be provided.
- *F. Water heating systems shall be adequate to fill the warewashing sink with 110°F water without interruptions and to supply hand sinks with three (3) gallons per hour of 100°F water at all times and other hot water using fixtures and equipment with a continuous supply of hot water. Standard tank type heating systems shall be sized in accordance with Section 5-108.
- G. The water inlet shall be located so that it will not be contaminated by waste discharge, road dust, oil, or grease, and it shall be kept capped unless being filled. The water inlet shall be provided with a connection of a size or type that will prevent its use for any other service. All water distribution pipes or tubing shall be constructed and installed in accordance with the requirements of these rules and regulations.
- *H. When a mobile retail food establishment is connected to a pressurized water supply, it shall be provided with approved backflow prevention devices. This shall include the protection of the water source as well as protection of each individual water service connection.
- *I. The water supply hose and couplings shall be of a size and type compatible with the water supply tank inlet fixture and shall be free of cracks and checks. Hose couplings shall be constructed to permit a tight connection between the mobile retail food establishment coupling and the water supply hose bib. Hose ends must be capped, connected or otherwise fully protected when not in use. Only food grade hoses shall be used to fill or transfer drinking water to or within a mobile retail food establishment or a pushcart.

- *J. Water systems and components shall be disinfected and flushed in accordance with 25-1.5-2, C.R.S., *Colorado Primary Drinking Water Regulations*, prior to use, if the mobile retail food establishment or push cart is not in daily use.

9-105 Wastewater Retention

- *A. A mobile retail food establishment or pushcart that does not meet all the restrictions of section 9-102 of these rules and regulations must provide a waste water retention tank. All liquid waste, except drainage from clean ice made with drinking water, generated by a mobile retail food establishment or pushcart shall be stored in a retention tank that is at least 15 percent larger than the water supply tank. Liquid waste shall be discharged from the retention tank to an approved sewage disposal system and flushed as often as necessary to maintain sanitary conditions. Discharge onto the surface of the ground shall be strictly prohibited. Drainage from uncontaminated ice made with drinking water can be discharged onto the surface of the ground provided it does not create a nuisance.
- B. All connections on the vehicle for servicing mobile food unit waste disposal facilities shall be of a different size or type than those used for supplying potable drinking water to the mobile food establishment. The waste water outlet connection shall be located lower than the drinking water inlet connection to prevent contamination of the drinking water system.
- C. Liquid waste discharge piping and the drinking water hose shall not be stored in a manner that may result in contamination.

***9-106 Handwashing Facilities**

A mobile retail food establishment or pushcart that does not meet all the exemptions of section 9-102 of these rules and regulations must be equipped with a convenient, accessible handsink installed as specified in Section 5-208(J) for employee handwashing. The handsink must be capable of providing a hands-free, continuous flow of 100°F water as specified in Section 9-104(F). Soap and individually dispensed paper towels must also be provided at the hand sink.

9-107 Commissary

- A. The commissary is considered to be an essential part of the mobile food retail food establishment and push cart operation. The commissary shall be constructed and operated in compliance with the requirements of these rules and regulations. Mobile retail food establishments and pushcarts shall operate from a commissary or other fixed retail food establishment and shall report every 24 hours (on operational days) to that location for supplies, cleaning and servicing operations.

The use of the proposed commissary for each mobile retail food establishments or pushcarts shall be submitted and approved by the department. The mobile retail food establishment or push cart shall provide an agreement from the commissary operator to the department each calendar year and upon change of a commissary location.

The agreement shall specify the mobile retail food establishment or push cart is allowed to report to the commissary daily, and is allowed to use the facility's warewashing equipment, refrigeration, food preparation equipment and storage areas as a base for operation. The agreement shall also specify how and where the commissary use log will be maintained. These commissary records shall be made available to the Department when requested.

- B. Accommodations for a servicing area shall be available with a drinking water supply for the mobile retail food establishment or push cart. Servicing may include vehicle and equipment cleaning, discharging liquid or solid wastes, refilling water tanks, and restocking of ice bins, and food.
1. Drinking water servicing equipment shall be installed according to the law and shall be stored and handled to protect the water and equipment from contamination according to section 5-101 and 5-102.
 2. The mobile retail food establishment and push cart liquid waste retention tank shall be thoroughly drained and flushed during servicing. All liquid waste shall be discharged to a sanitary sewage system in accordance with section 5-211 of these rules and regulations.
 3. There shall be a location provided for the flushing and drainage of liquid wastes that is separate from the location provided for obtaining drinking water and for the loading and unloading of food and related supplies.
- C. When servicing areas are provided as part of the commissary, the floor surfaces of the servicing area shall be constructed of a smooth, nonabsorbent material such as concrete or machine-laid asphalt and shall be maintained in good repair, kept clean, and be graded to drain.
- The construction of the walls and ceilings of the servicing area is exempt from the provisions of sections 6-201 and 6-202 of these rules and regulations.
- D. A self-contained mobile retail food establishment is not required to report to a commissary if:
1. Adequate storage areas are provided within the mobile retail food establishment for food, dry goods, single service articles and cleaning supplies; and
 2. Adequate facilities including a hand sink, food preparation sink, warewashing facilities, mop sink, mechanical refrigeration, and any additional equipment are provided as required by the menu.
 3. Adequate accommodations for food preparation, storage of food, equipment, utensils and other supplies; and
 4. Approved arrangements and facilities are provided and used to supply drinking water to the mobile unit and for the disposal of wastewater generated by the establishment; and
 5. A written operational plan is submitted by the mobile retail food establishment, which demonstrates that this process can be accomplished in compliance with these rules and regulations. Review and approval of this plan must include the menu and standard operating procedures for the mobile unit. Once an operational plan is approved, any additions or changes to the approved plan must be approved by the Department prior to implementation. The approved operational plan must be available on the mobile retail food establishment at all times.
- E. A mobile retail food establishment is prohibited from acting as a commissary for another retail food establishment.

9-108 Additional Requirements

- A. Spare tires, tools, and other equipment relating to the mechanical operation of the vehicle shall be stored in a way that does not contaminate food, food equipment, or utensils.
- B. Except for service windows, any openable windows and doors must be screened. Service windows must be self-closing.
- C. Restroom facilities shall be available to employees at all times that the mobile retail food establishment or pushcart is in operation.
- *D. Equipment shall be adequate to maintain potentially hazardous foods (time/temperature control for safety foods) at required temperatures in accordance with Parts 3-5 and 3-6. In addition:
 - 1. Mobile retail food establishments shall utilize mechanical refrigeration to hold and serve potentially hazardous foods (time/temperature control for safety foods).
 - 2. Pushcarts may use no more than two (2) hard sided coolers to maintain food at required temperatures. One cooler shall be used for all raw animal foods and the other cooler for all other potentially hazardous foods (time/temperature control for safety foods). If the facility needs additional refrigeration space, the push cart shall provide commercial mechanical refrigeration.
- *E. Mobile retail food establishments and pushcarts shall provide enough clean utensils to satisfy the requirements of section 4-407(C).
- F. Items for customer self service shall be adequately protected from contamination.

CHAPTER 10

TEMPORARY RETAIL FOOD ESTABLISHMENTS

10-1 TEMPORARY RETAIL FOOD ESTABLISHMENTS

10-101 General

A temporary retail food establishment shall comply with all requirements of these rules and regulations, except as otherwise provided in this chapter.

A temporary event vendor application, which shall include a list of food items to be sold, shall be submitted to the Department for each event. The vendor application shall be submitted at least ten (10) working days prior to the event. Approval will be based upon menu, equipment, setup and the ability to protect against public health hazards.

Mobile Retail Food Establishments and Pushcarts operating at temporary events shall operate according to chapter 9 of these rules and regulations.

10-102 Operations

- *A. Food preparation at the event shall be limited to seasoning, cooking, assembly of pre-prepared foods and service of packaged foods stored at required temperatures.
- *B. All slicing, chopping, peeling, dicing, shredding and washing of produce shall be done at an approved commissary.
- C. Food and food-contact surfaces of equipment shall be protected from contamination by consumers or other sources. Appropriate coverings, packaging, shields, barriers, or other means shall be provided as necessary to prevent contamination.
- *D. Equipment shall be maintained and operated per its intended use and design.
- E. Equipment shall be located and installed to facilitate cleaning. No grease from grease producing equipment shall discharge onto the ground or into any storm drainage system.

10-103 Commissary

- A. Temporary Retail Food Establishment vendors shall operate from a commissary approved by the Department and shall provide a commissary agreement to the Department for each event. Vendors with limited menus operating from licensed self-contained mobile units in accordance with section 9-107(D) may be allowed to operate without a commissary.
- B. The commissary for vendors operating at an event of more than one (1) day in duration shall be within 30 minutes or 30 miles of the event.
- C. All foods, utensils, and single use articles shall be transported from the commissary to the event site in a manner that protects them from contamination. Food product temperature shall be maintained as required in section 3-501.

- D. The commissary shall be constructed and operated in compliance with the requirements of these rules and regulations. Temporary retail food establishments shall operate from a commissary or other fixed retail food establishment and shall report at a minimum of every 24 hours (on operational days) to that location for all supplies, all cleaning, advanced food preparation, and servicing operations. The commissary operator, as requested by the Department, shall verify to the Department when the temporary retail food establishment reports to the commissary.
1. The agreement shall specify the temporary retail food establishment is allowed to report to the commissary daily, is allowed to use the facility's warewashing equipment, refrigeration, food preparation equipment and storage areas as a base for operation. The commissary operator shall maintain written documentation or a log as to when the temporary retail food establishment utilizes the commissary. These records shall be made available to the Department when requested.
 2. Temporary retail food establishment operators shall maintain written records of purchases detailing the source of all foods being held, stored, offered for sale, sold and distributed and expenses including receipts for expenditures such as servicing operations. These records shall be made available to the Department when requested.

10-104 Minimum Event Site Equipment Requirements

- *A. Equipment for heating and holding food cold and hot, shall be sufficient in number and capacity to maintain foods at required temperatures. Equipment utilizing fuel gel canister is prohibited at outdoor venues unless approved by the Department.
- *B. A conveniently located hand washing station shall be provided within the Temporary Retail Food Establishment.
- *C. Extra utensils and in-use food contact surfaces (cutting boards, tongs, knives, etc.) shall be provided to allow soiled items to be replaced at a minimum of every four (4) hours. Warewashing of equipment and utensils shall be conducted at an approved facility. Onsite warewashing is prohibited unless otherwise approved by the Department.
- D. A sufficient number of smooth, non-absorbent, and easily cleanable work surfaces shall be provided where food is being handled.
- E. Coolers and containers used to store food shall be durable, smooth, non-absorbent and easily cleanable. Styrofoam and soft sided coolers are prohibited.
- F. A clean trash receptacle shall be provided.

***10-105 Ice**

Only ice which has been manufactured from drinking water and handled in a sanitary manner shall be used or offered for sale. Ice used as a cooling medium for food storage, beverage containers, food containers or food utensils shall not be used or sold for human consumption.

10-106 Single-Service Articles

All temporary retail food establishments shall provide only single-service articles for use by the consumer.

***10-107 Water**

A sufficient quantity of drinking water shall be available for food preparation, wiping cloth solutions, and sanitization of food-contact surfaces. The water supply system hoses, piping, and fixtures shall be fabricated of approved food-contact materials. The water supply system must be installed to preclude the backflow of contaminants into the drinking water supply.

10-108 Wet Storage

Packaged food may be stored in direct contact with drinking ice or drinking water if the packaging, wrapping, or container is not subject to entry of water. The storage of food and/or beverage, in undrained ice is prohibited.

***10-109 Waste**

All sewage, including liquid waste, shall be disposed of according to law. Waste water shall not be discharged onto ground or into storm drainage system. Drainage from clean drinking ice may be discharged onto the surface of the ground provided it does not create a nuisance.

***10-110 Handwashing**

- A. A minimum of five (5) gallons of drinking water shall be provided for hand washing. The required volume of water will be based upon menu, equipment, and hours of operation. Push button spigots on the water supply containers are not permitted.
- B. Soap and dispensed paper towels shall be provided at each hand washing station.
- C. A hand washing station that is capable of providing hands-free continuous flowing warm water of adequate pressure shall be provided.
- D. A basin that is capable of capturing hand washing waste water and conveying it into a closed waste water container shall be provided.

***10-111 Screening and Enclosures**

Screening or other provisions may be required to prevent the entrance of pests and debris.

***10-112 Grounds**

Areas within the Temporary Retail Food Establishment shall be free from standing water, mud, dust and fecal material. Additional ground covering material may be required such as removable platforms, duckboards, wood chips or other suitable material.

***10-113 Overhead Protection**

Overhead protection shall be provided and be made of wood, canvas, or other materials that protect the interior of the establishment from weather, or other contamination. Any grease producing equipment or equipment with open flames shall not be located under overhead protection.

CHAPTER 11

COMPLIANCE PROCEDURES

11-1 COMPLIANCE

11-101 General

A person shall have a valid retail food establishment license, certificate of license, as defined in section 25-4-1602, C.R.S. and administration and inspection fees pursuant to sections 25-4-1607, C.R.S., to operate a retail food establishment. A person operating a retail food establishment without a valid license, certificate of license or appropriate administration and inspection fees may be prosecuted under sections 16-13-305, 25-4-1609, and 25-14-1610 C.R.S. Only a person who complies with the requirements of these rules and regulations shall be entitled to receive or retain such a license or certificate. Licenses, certificates, or administration and inspection fees are not transferable. When issued, a valid license or certificate shall be posted in every retail food establishment.

11-102 Issuance of License or Certificate of License

- A. Any person desiring to operate a retail food establishment shall make written application for a license or certificate of license or pay administration and inspections fees using forms provided by the Department. Each application form shall include the name and address of each applicant, the location and type of the proposed retail food establishment, and the signature of each applicant.
- B. Prior to approval of an application for a license or certificate of license, the Department may inspect the proposed retail food establishment to determine compliance with the rules and regulations.
- C. The Department shall approve a license or certificate of license for the applicant if its inspection reveals that the proposed retail food establishment complies with the requirements of these rules and regulations.
- D. An existing Retail Food Establishment shall be required to obtain a new Retail Food Establishment license when there is a change of ownership that requires a new Colorado Department of Revenue Sales Tax Account Number, or if the physical location of the establishment changes.

11-103 License Renewal

The Department may refuse to renew a retail food establishment license or certificate of license for any violation of sections 25-4-1601 et seq., C.R.S., of these rules and regulations, or as otherwise provided by law. This notification shall be presented to license or certificate holders during the last quarter of each calendar year. Denial of a license renewal shall be treated in all respects as a revocation and, hence, procedures for revocation shall be followed. In a case in which the license or certificate holder has made timely and sufficient application for renewal of license, the existing license shall not expire until such application has been finally acted upon by the Department.

11-104 Judicial Review

A license or certificate holder adversely affected or aggrieved by a Departmental action may appeal the final action of the Department as provided in section 24-4-106, C.R.S. Suspension or

revocation of a license may be reviewed, upon application for an order in the nature of mandamus or otherwise, by any court of general jurisdiction as provided in section 25-4-1609, C.R.S.

11-105 Closure Without Suspension

Acting under sections 25-1.5-101(1)(a) and 25-1.5-102(1)(a) & (d), C.R.S., the Department, or its authorized representative, shall have the power and duty to close retail food establishments and forbid the gathering of people therein to protect the public health from the cause of epidemic and communicable diseases. Immediate closure shall be used only when the situation imperatively requires emergency action or the operator has been guilty of deliberate and willful violation that is injurious or creates an imminent public health hazard as defined in Section 1-201(A)(57).

11-106 Injunctive Relief

When serious or repeated violations of these rules and regulations have been found, the Department or its authorized agents may abate the nuisance by seeking injunctive relief through judicial means, as provided under section 16-13-308 and 309, C.R.S.

11-2 INSPECTIONS

11-201 Inspection Frequency

- A. An inspection of a retail food establishment shall be performed at least twice every calendar or fiscal year; or
- B. The *Colorado Retail Food Establishment Risk-Based Inspectional Frequency Methodology Guidance Document* may be used as a model for an alternative method for determining inspectional frequency. If this model is modified by an agency, the agency must be able to defend the modifications utilizing the public health risk factors contained in the model. The public health risk factors include: 1) food served, 2) operations, 3) weekly meal volume, and 4) inspectional history including critical and non-critical violations. The minimum inspection frequency for an establishment falling in the low risk category is once every two years.
- C. Additional inspections may be performed based upon additional assessments of potential risks of foodborne illness including a history of non-compliance with these rules and regulations; the hazards associated with the particular foods being prepared, stored or served; the method and extent of food storage, preparation and service; and the number and demographic characteristics of the consumers.

11-202 Access

Agents of the Department, after proper identification, shall be permitted to enter any retail food establishment during business hours and at other times during which activity is evident in accordance with 25-4-1604(1)(e) to determine compliance with these rules and regulations. The agents shall be permitted to examine documents or true copies of documents, excluding prices, that pertain directly to food and supplies purchased, received or used, information pertinent to their HACCP plan, or to persons employed in food and beverage operations when such examination is expected to produce information necessary to protect the public health, enforce these rules and regulations or investigate suspected incidents of foodborne illnesses.

11-203 Report of Inspections

Whenever an inspection of a retail food establishment or commissary is made, the findings shall be recorded on an inspection report form. The inspection report form shall summarize the requirements of these rules and regulations. The Department shall document, on the inspection report form, specific factual observations of violative conditions or other deviations from these rules and regulations. Once the inspection has been completed and the inspection report form is finalized, a copy of the completed inspection report form shall be furnished to the person in charge of the establishment. The completed inspection report form is a public document that shall be made available for public disclosure to any person who requests it according to law.

11-204 Correction of Violations

- A. The inspection report form shall specify a reasonable period of time for the correction of the violations found and correction of the violations shall be accomplished within the period specified, in accordance with the following provisions:
 - 1. If an imminent health hazard exists, such as, but not limited to, absence of adequate of refrigeration, no water supply, non functional water heating system, severe and active pest infestation, or sewage backup into the establishment, the establishment shall immediately cease food operations. Operations shall not be resumed until authorized by the Department.
 - 2. All critical violations are to be corrected as soon as possible, but in any event, by the date and time specified by the Department, but in no case to exceed ten (10) days.
 - 3. All non-critical violations shall be corrected by the date and time agreed to or specified by the Department based upon the severity of potential health hazards, which could result from the non-critical violation. The Department is not required to conduct follow-up activities on non-critical violations.
- B. The inspection report shall state that failure to comply with any time limits may result in the initiation of administrative or legal regulatory action. An opportunity for appeal of the inspection findings and time limitation will be provided if a written request for an administrative hearing is filed with the Department within thirty (30) days following the date of receipt of inspection. If the request for a hearing is received, a hearing shall be held no sooner than twenty (20) days after the operator is notified of the hearing.
- C. Whenever a retail food establishment is required under the provisions of these rules and regulations to cease operations, it shall not resume operations until a re-inspection determines that conditions responsible for the requirement to cease operations no longer exists. Opportunity for re-inspection shall be offered within a reasonable time.

11-205 Inspection Report

The format of an inspection form shall be based upon critical and non-critical categories. The following items must be included:

Item	Category
FOOD SOURCE DATE MARKING AND CONSUMER ADVISORY	CRITICAL
a. Approved source	
b. Wholesome, free of spoilage	
c. Cross-contamination	
d. Specialized Processes/HACCP plan	
e. Date marking	
f. Consumer Advisory	
PERSONNEL	CRITICAL
Employee Health	
a. Personnel with infections restricted	
b. Wounds properly covered	
Hygienic Practices	
c. Hands washed as needed	
d. Hygienic practices	
e. Smoking, eating, drinking	
Demonstration of knowledge	
f. Training needed	
g. Preventing food contamination from bare hands	
FOOD TEMPERATURE CONTROL	CRITICAL
Temperature Control Procedures	
a. Rapidly cool foods to 41° F or less	
b. Rapidly reheat to 165° F or greater	
c. Hot hold at 135° F or greater	
d. Required cook temperature	
e. Cold hold at 41° F or less	
Temperature Control Equipment	
f. Use of Food thermometer (probe-type)	
g. Adequate equipment to maintain food temperatures	
SANITIZATION RINSE	CRITICAL
a. Clean	
b. Temperature	
c. Concentration	
d. Exposure	

Item	Category
WATER, SEWAGE, PLUMBING SYSTEMS a. Safe water source b. Hot and cold water under pressure c. Backflow, backsiphonage d. Sewage disposal	CRITICAL
HANDWASHING FACILITIES a. Adequate number, location b. Accessible c. Soap and drying devices available	CRITICAL
PEST CONTROL a. Evidence of insects or rodents b. Pesticide application c. Animals prohibited	CRITICAL
POISONOUS OR TOXIC ITEMS a. Properly stored b. Properly labeled c. Properly used	CRITICAL
FOOD LABELING , FOOD PROTECTION a. Original container, properly labeled b. Food protected from contamination	NON-CRITICAL
EQUIPMENT DESIGN CONSTRUCTION a. Food-contact surfaces b. Nonfood-contact surfaces c. Dishwashing facilities	NON-CRITICAL
TESTING DEVICES a. Refrigeration units provided with accurate, conspicuous thermometers b. Dishmachines provided with accurate thermometer and gauge cock c. Chemical test kits provided, accessible	NON-CRITICAL
CLEANING OF EQUIPMENT AND UTENSILS a. Food-contact surfaces b. Nonfood-contact surfaces c. Dishwashing operations d. Wiping cloths	NON-CRITICAL

Item	Category
UTENSILS, SINGLE SERVICE ARTICLES a. Utensils provided, used, stored b. Single-service articles stored, dispensed, used c. No reuse of single-service articles	NON-CRITICAL
PHYSICAL FACILITIES a. Plumbing: installed, maintained b. Garbage and refuse c. Floors, walls, ceiling d. Lighting e. Ventilation f. Locker rooms g. Premises maintained h. Separation of living, laundry i. Restroom facilities	NON-CRITICAL
OTHER OPERATIONS a. Personnel: clean clothes, hair restraints, authorized b. Linen properly stored	NON-CRITICAL

11-3 CONDEMNATION AND EMBARGO OF FOOD

11-301 General

The power and duty to condemn and embargo food that the Department finds probable cause to believe is in violation of section 3-101 of these rules and regulations has been given to the Department under the statutory authority of sections 25-1.5-104(a) and 25-5-406 et. seg., C.R.S.

11-302 Voluntary Condemnation.

When the Department finds food that it has probable cause to believe is in violation of section 3-101 of these rules and regulations, the Department shall bring the fact to the attention of the person in charge and request that the food be voluntarily destroyed. If the person in charge agrees to destroy the suspect food, a voluntary condemnation agreement shall be completed and signed. The person in charge shall denature the food under the supervision of the Department. A copy of the voluntary condemnation agreement shall be left with the person in charge.

11-303 Embargo Placement

When the Department finds food that it has probable cause to believe is in violation of section 3-101 of these rules and regulations, the Department shall bring the fact to the attention of the person in charge and request that the food be voluntarily destroyed. Should the person in charge refuse to voluntarily destroy the food, the Department shall embargo the remainder of the food. An embargo notice shall be completed and signed. A copy of the embargo notice shall be left with the person in charge. The remainder of the food product shall be set aside for storage in a container sealed with sampling tape to prevent usage. No person shall remove or dispose of such embargoed article by sale or otherwise.

11-304 Embargo Release

- A. The Department shall complete and sign an embargo release which dictates the subsequent disposition of the product by:
 - 1. Use of the product in the establishment where it was found if demonstrated to be in compliance with section 3-101 of these rules and regulations; or
 - 2. Use of the product by other approved means; or
 - 3. Destruction of the product.
- B. A copy of this release shall be given to the person in charge.
- C. Neither the Department nor the State shall be held liable for damages because of such embargo.

11-305 Condemnation of Product

Should the food be found to be not sound or contaminated with filth and a voluntary destruction cannot be obtained, the Department shall petition the court of jurisdiction for seizure and disposition of the food.

11-4 REVIEW OF PLANS

11-401 Submission of Plans

It shall be necessary to submit to the Department detailed plans and specifications of a proposed newly constructed retail food establishment and or the affected areas of any proposed extensively remodeled retail food establishment. Each retail food operator, or person intending to become a retail food operator, shall be responsible for submitting all plans and specifications. Those assisting an operator may submit plans and specifications on the operator's authority. The Department shall be consulted before preparation of plans and specifications. Approval of both plans and specifications is necessary before construction begins. A minimum of two (2) weeks shall be necessary for the Department to review the plans. Any revision of plans shall be submitted to the Department for review and modification or approval.

11-402 Contents of Plans and Specifications

Contents of the plans and specifications shall show evidence that the facility complies with applicable portions of these rules and regulations. A plan-view scale drawing of the establishment shall be provided. The plans shall include the location of all retail food equipment, plumbing fixtures and connections, ventilation systems, menu and other pertinent information. A dimensional sketch of the entrance, exits, streets, roadways and alleys shall also be included. Specifications shall be provided on a form supplied by the Department.

11-403 Contents of a HACCP Plan

- A. For a food establishment that is required in section 3-506 to have a HACCP plan, the plan and specifications shall indicate:
 - 1. A categorization of the types of potentially hazardous foods (time/temperature control for safety foods) that are specified in the menu such as soups and sauces, salads, and bulk, solid food such as meat roasts, or of other foods that are specified by the Department;

2. A flow diagram by specific food or category type identifying critical control points and providing information on the following:
 - a. Ingredients, materials, and equipment used in the preparation of that food; and
 - b. Formulations or recipes that delineate methods and procedural control measures that address the food safety concerns involved;
3. Food employee and supervisory training plan that addresses the food safety issues of concern.
4. A statement of standard operating procedures for the plan under consideration including clearly identifying:
 - a. Each critical control point;
 - b. The critical limits for each critical control point;
 - c. The method and frequency for monitoring and controlling each critical control point by the food employee designated by the person in charge;
 - d. The method and frequency for the person in charge to routinely verify that the food employee is following standard operating procedures and monitoring critical control point;
 - e. Action to be taken by the person in charge if the critical limits for each critical control point are not met; and
 - f. Records to be maintained by the person in charge to demonstrate that the HACCP plan is properly operated and managed; and
5. Additional scientific data or other information, as required by the Department, supporting the determination that food safety is not compromised by the proposal.

11-404 Pre-Operational Inspection.

Whenever plans and specifications are required by section 11-401 of these rules and regulations to be submitted to the Department, the Department shall inspect the retail food establishment prior to its beginning operation to determine compliance with the approved plans and specifications and with the requirements of these rules and regulations. It shall be necessary to arrange for a pre-opening inspection fourteen (14) days in advance of the date of the intended inspection. For areas of the state without a Local Health Department, it shall be necessary to arrange for a pre-opening inspection twenty-one (21) days in advance of the date of the intended inspection.

11-5 PROCEDURE WHEN INFECTION IS SUSPECTED

11-501 General

When the Department has reasonable cause to suspect the possibility of disease transmission from any retail food establishment employee, it may secure a morbidity history of the suspected employee or make any other investigation as necessary and shall take appropriate action. The Department may require any or all of the following measures:

- A. The immediate exclusion of the employee from all retail food establishments in accordance with 2-202;

- B. The immediate closing of the retail food establishment concerned until, in the opinion of the Department, no further danger of disease outbreak exists;
- C. Restriction of the employee's services to some area of the establishment where there would be no danger of disease transmission in accordance with 2-203;
- D. Adequate medical and laboratory examination of the employee and other employees in accordance with 2-203.

11-6 VARIANCE PROCEDURE

11-601 Variance Procedure

- A. Any retail food establishment may request a variance from any requirement of these rules and regulations when such an establishment believes that the requirement results in an undue economic hardship or when it is believed a standard may not apply to the specific situation.
- B. Requests shall be submitted in writing to the Colorado Department of Public Health and Environment and shall include the name and location of the business, the name of the licensee or prospective licensee when applicable, and the section for which a variance is being requested. This request must be accompanied with a recommendation for approval or denial from the health agency of jurisdiction. Evidence of undue economic hardship should include estimates and costs for compliance. If it is believed that a standard may not apply to the specific situation, an explanation shall be included.
- C. Any person who requests a variance for the provisions of these regulations shall have the burden of supplying the Department with information that demonstrates the conditions exist which warrant the granting of a variance. All doubts shall be resolved in favor of denial.
- D. The Colorado Department of Public Health and Environment may grant a variance if:
 1. Such variance is consistent with the purpose and intent of the act and these regulations; and
 2. It is consistent with the protection of the public health; and
 3. The circumstances of the retail food establishment are unique; and
 4. The cost of compliance is so great that it would threaten economic viability of the retail food establishment or the retail food establishment would be in grave jeopardy if compliance were enforced; and
 5. The damage to the retail food establishment's economic viability is in fact caused by compliance.
- E. A variance shall expire upon a change of circumstances from those supporting the variance or upon a change of ownership of the retail food establishment. The approved variance and all associated documentation shall be located at the establishment and made available to the Department when requested.
- F. After review and in circumstances where the Department intends to deny a variance, the Department shall refer the request to an advisory panel of three persons, two persons who represent the retail food industry and a representative from a local health department, to make recommendations to the Department.

- G. Any retail food establishment for which a variance has been denied may appeal such denial by requesting a hearing which will be held in accordance with section 24-4-105 (15), C.R.S.

11-7 REFERENCE CITATIONS

11-701 General

These regulations incorporated by reference (as indicated within) materials originally published elsewhere. Such incorporation does not include later amendments to or editions of the referenced material. The Department maintains certified copies of the complete text of any material incorporated by reference for public inspection during regular business hours and shall provide certified copies of the incorporated material at cost upon request. Information regarding how to obtain or examine the incorporated material is available from the Division Director, Division of Environmental Health and Sustainability, Colorado Department of Public Health and Environment, 4300 Cherry Creek Drive South, Denver, CO 80246-1530.

Copies of the incorporated materials have been provided to the State Publications Depository and Distribution Center, and are available for interlibrary loan. Any incorporated material may be examined at any State Publications Depository Library.

11-702 Safe Materials

The Colorado Pure Food and Drug Law, the Federal Food, Drug and Cosmetic Act and applicable regulations of the U.S. Food and Drug Administration used for the determination of material safety in section 1-202(56) of these rules and regulations may be obtained from the Division Director, Division of Environmental Health and Sustainability, Colorado Department of Public Health and Environment, 4300 Cherry Creek Drive South, Denver, CO 80246-1530 and/or the U.S. Federal Food and Drug Administration.

11-703 Food Protection Act

Copies of section 25-4-1601 et seq., C.R.S may be obtained from the Director of the Division of Environmental Health and Sustainability of the Colorado Department of Public Health and Environment.

11-704 Milk Standards

Copies of the Grade A Standards referenced in section 3-305 of these regulations may be obtained from the Director of the Division of Environmental Health and Sustainability of the Colorado Department of Public Health and Environment.

11-705 Ventilation Requirements

Copies of the 2006 International Mechanical Code or Local Ventilation Codes referenced in section 4-212 of these rules and regulations may be obtained from the International Conference of Building Officials, 503 Alhambra Avenue, Los Angeles, California 90032-3490 or the Local Building Department of jurisdiction, respectively.

11-706 Code of Federal Regulations

Copies of the (2005) Code of Federal Regulations referenced in sections 3-101, 3-312, 3-408, 3-607, 3-702, 4-202, 4-207, 4-403, 4-404, 5-103, 5-108, 7-105, 7-107, 7-108 may be obtained from the Director, Office of the Federal Register, National Archives and Records Administration, Washington DC 20408.

11-707 Plumbing Requirements

Copies of the 2009 International Plumbing Code or Local Plumbing Codes referenced in sections 5-201, 5-208, and 5-209 may be obtained from the International Association of Plumbing and Mechanical Officials, 20001 Walnut Drive South, Walnut, California, 91789-2825 and/or the Local Building Department of jurisdiction, respectively.

11-708 Administrative Statutes

Copies of sections 16-13-305, 306 and 308, C.R.S.; 24-4-106, C.R.S.; 25-1.5-101(1)(a), C.R.S.; 25-1-108 (1)(k), C.R.S.; 25-1-506 (1)(d), C.R.S.; 25-4-401 et seq., C.R.S.; 25-4-1301 et seq., C.R.S.; 25-4-105, C.R.S.; 25-4-1608, C.R.S.; and 25-5-406 (1) and (4) C.R.S., referenced in sections 1-202, 3-305, 3-401, 3-409, 3-410, 3-701, 5-101, 9-104, 11-101, 11-103, 11-104, 11-105, 11-106, 11-301, and 11-601 of these rules and regulations may be obtained from the Director of the Division of Environmental Health and Sustainability of the Colorado Department of Public Health and Environment.

11-709 American National Standards Institute (ANSI)

Copies of the National Sanitation Foundation Standards for food equipment that are classified for sanitation by an American National Standards Institute (ANSI) accredited certification program referenced in section 4-101 of these rules and regulations may be obtained from the Director of the Division of Environmental Health and Sustainability of the Colorado Department of Public Health and Environment.

APPENDIX A - Potentially Hazardous Foods

Potentially hazardous food (PHF/TCS food) is defined in terms of whether or not it requires time/temperature control for safety to limit pathogen growth or toxin formation. The term does not include foods that do not support growth but may contain a pathogenic microorganism or chemical or physical food safety hazard at a level sufficient to cause foodborne illness or injury. The progressive growth of all foodborne pathogens is considered whether slow or rapid.

The definition of PHF/TCS food takes into consideration pH, a_w , pH and a_w interaction, heat treatment, and packaging for a relatively simple determination of whether the food requires time/temperature control for safety. If the food is heat-treated to eliminate vegetative cells, it needs to be addressed differently than a raw product with no, or inadequate, heat treatment. In addition, if the food is packaged after heat treatment to destroy vegetative cells and subsequently packaged to prevent re-contamination, higher ranges of pH and/or a_w can be tolerated because remaining spore-forming bacteria are the only microbial hazards of concern. While foods will need to be cooled slightly to prevent condensation inside the package, they must be protected from contamination in an area with limited access and packaged before temperatures drop below 135°F (57°C). In some foods, it is possible that neither the pH value nor the a_w value is low enough by itself to control or eliminate pathogen growth; however, the interaction of pH and a_w may be able to accomplish it. This is an example of a hurdle technology. Hurdle technology involves several inhibitory factors being used together to control or eliminate pathogen growth, when they would otherwise be ineffective if used alone. When no other inhibitory factors are present and the pH and/or a_w values are unable to control or eliminate bacterial pathogens which may be present, growth may occur and foodborne outbreaks result. Cut melons, cut tomatoes, and cut leafy greens are examples where intrinsic factors are unable to control bacterial growth once pathogens are exposed to the cellular fluids and nutrients after cutting.

In determining if time/temperature control is required, combination products present their own challenge. A combination product is one in which there are two or more distinct food components and an interface between the two components may have a different property than either of the individual components. A determination must be made about whether the food has distinct components such as pie with meringue topping, focaccia bread, meat salads, or fettuccine alfredo with chicken or whether it has a uniform consistency such as gravies, puddings, or sauces. In these products, the pH at the interface is important in determining if the item is a PHF/TCS food.

A well designed inoculation study or other published scientific research should be used to determine whether a food can be held without time/temperature control when:

- process technologies other than heat are applied to destroy foodborne pathogens (e.g., irradiation, high pressure processing, pulsed light, ozonation);
- combination products are prepared; or
- other extrinsic factors (e.g., packaging/atmospheres) or intrinsic factors (e.g., redox potential, salt content, and antimicrobials) are used to control or eliminate pathogen growth.

Before using Tables A and B listed in the definition section under item 79 for "potentially hazardous food (time/temperature control for safety food)" in determining whether a food requires time/temperature control for safety (TCS), answers to the following questions should be considered:

- Is the intent to hold the food without using time or temperature control?
 - If the answer is No, no further action is required. The decision tree later in this Appendix is not needed to determine if the item is a PHF/TCS food.
- Is the food raw, or is the food heat-treated?

- Does the food already require time/temperature control for safety utilizing the definition of "potentially hazardous food (time/temperature control for safety food)"?
- Does a product history with sound scientific rationale exist indicating a safe history of use?
- Is the food processed and packaged so that it no longer requires TCS such as ultra high temperature (UHT) creamers or shelf-stable canned goods?
- What is the pH and a_w of the food in question using an independent laboratory and Association of Official Analytical Chemists (AOAC) methods of analysis?

A food designated as product assessment required (PA), in either table should be considered PHF/TCS Food until further study proves otherwise. The PA means that based on the food's pH and a_w and whether it was raw or heat-treated or packaged, it has to be considered PHF until inoculation studies or some other acceptable evidence shows that the food is a PHF/TCS food or not. The Rules and Regulations require a variance request to the regulatory authority with the evidence that the food does not require time/temperature control for safety.

The Rules and Regulations definition designates certain raw plant foods as PHF/TCS food because they have been shown to support the growth of foodborne pathogens in the absence of temperature control and to lack intrinsic factors that would inhibit pathogen growth. Unless product assessment shows otherwise, these designations are supported by Tables A and B. For example:

For cut cantaloupe (pH 6.2-7.1, $a_w > 0.99$, not heat-treated), fresh sprouts (pH > 6.5 , $a_w > 0.99$, not heat-treated), and cut tomatoes (pH 4.23 - 5.04, $a_w > 0.99$, not heat-treated), Table B indicates that they are considered PHF/TCS Foods unless a product assessment shows otherwise. Maintaining these products under the temperature control requirements prescribed in this code for PHF/TCS food will limit the growth of pathogens that may be present in or on the food and may help prevent foodborne illness.

If a facility adjusts the pH of a food using vinegar, lemon juice, or citric acid for purposes other than flavor enhancement, a HACCP plan and approval from the department is required under 3-606. A HACCP plan is required whether the food is a PHF/TCS food as in Section 3-606 (A)(3)(a) of these rules and regulations or not a PHF/TCS food, as in Section 3-606(A)(3)(a) of these rules and regulations. A standardized recipe validated by lab testing for pH and a_w would be an appropriate part of the approval process with annual (or other frequency as specified by the regulatory authority) samples tested to verify compliance with the conditions of the variance.

Instructions for using the following Decision Tree and Table A and Table B:

1. Does the operator want to hold the food without using time or temperature control?
 - a. No - Continue holding the food at $\leq 41^\circ\text{F}$ (5°C) or $\geq 135^\circ\text{F}$ (57°C) for safety and/or quality.
 - b. Yes - Continue using the decision tree to identify which table to use to determine whether time/temperature control for safety (TCS) is required.
2. Is the food heat-treated?
 - a. No - The food is either raw, partially cooked (not cooked to the temperature specified in section 3-502 of the Rules and Regulations) or treated with some other method other than heat. Proceed to step #3.
 - b. Yes - If the food is heat-treated to the required temperature for that food as specified under section 3-502 of the Rules and Regulations, vegetative cells will be destroyed although spores will survive. Proceed to step #4.
3. Is the food treated using some other method?

- a. No - The food is raw or has only received a partial cook allowing vegetative cells and spores to survive. Proceed to step #6.
 - b. Yes - If a method other than heat is used to destroy pathogens such as irradiation, high pressure processing, pulsed light, ultrasound, inductive heating, or ozonation, the effectiveness of the process needs to be validated by inoculation studies or other means. Proceed to step #5.
4. Is it packaged to prevent re-contamination?
- a. No - Re-contamination of the product can occur after heat treatment because it is not packaged. Proceed to step #6.
 - b. Yes - If the food is packaged immediately after heat treatment to prevent re-contamination, higher ranges of pH and/or a_w can be tolerated because spore-forming bacteria are the only microbial hazard. Proceed to step #7.
5. Further product assessment or vendor documentation required.
- a. The vendor of this product may be able to supply documentation that inoculation studies indicate the food can be safely held without time/temperature control for safety.
 - b. Food prepared or processed using new technologies may be held without time/temperature control provided the effectiveness of the use of such technologies is based on a validated inoculation study.
6. Using the food's known pH and/or a_w values, position the food in the appropriate table.
- a. Choose the column under "pH values" that contains the pH value of the food in question.
 - b. Choose the row under " a_w values" that contains the a_w value of the food in question.
 - c. Note where the row and column intersect to identify whether the food is "non-PHF/non-TCS food" and therefore does not require time/temperature control, or whether further product assessment (PA) is required. Other factors such as redox potential, competitive microorganisms, salt content, or processing methods may allow the product to be held without time/temperature control but an inoculation study is required.
7. Use **Table A** for foods that are heat-treated and packaged **OR** use **Table B** for foods that are not heat-treated or heat-treated but not packaged.
8. Determine if the item is non-PHF/non-TCS or needs further product assessment (PA).

**DECISION TREE #1 - USING pH, A_w , OR THE INTERACTION OF
pH AND A_w TO DETERMINE IF A FOOD REQUIRES
TIME/TEMPERATURE CONTROL FOR SAFETY**

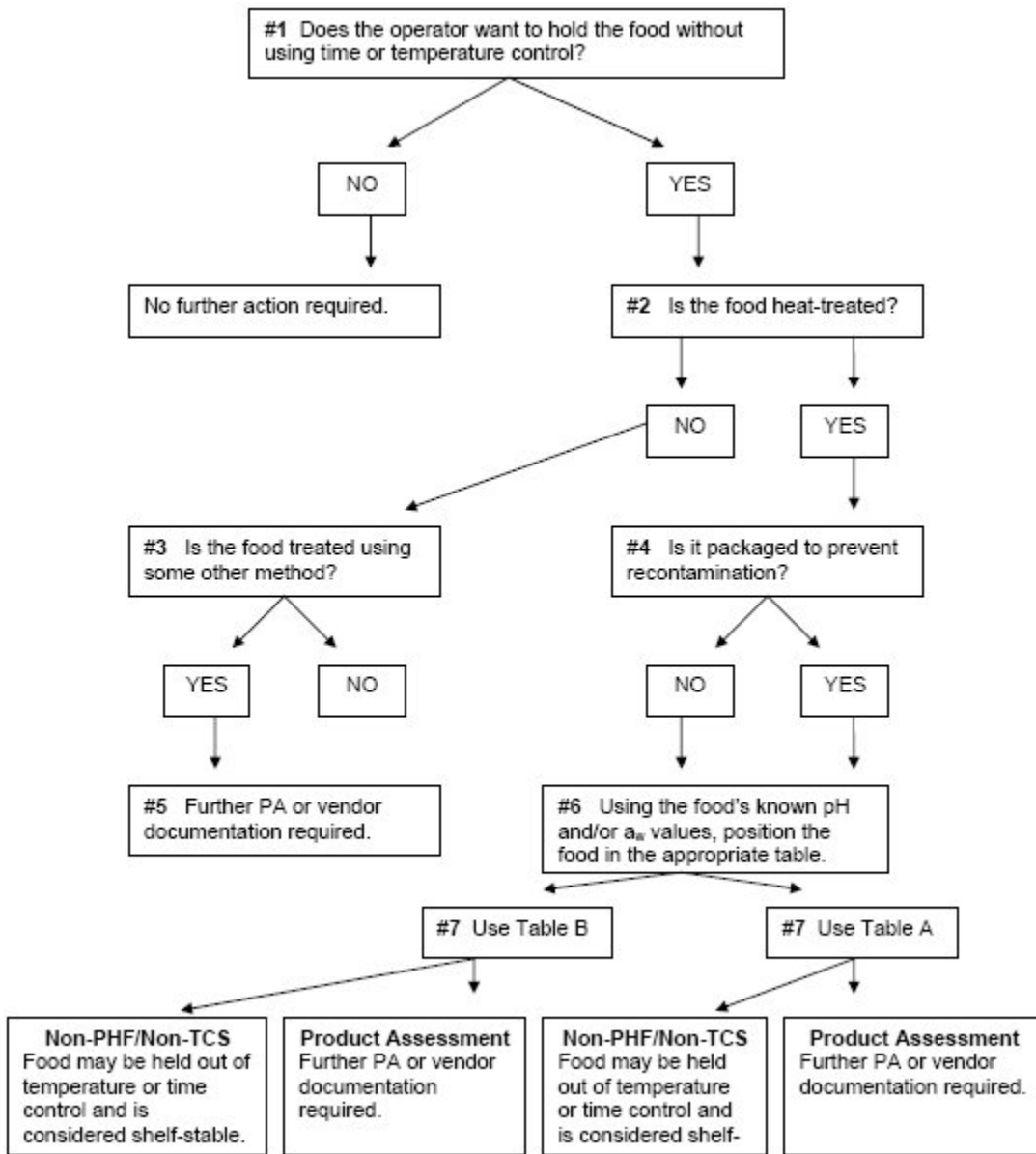

TABLE A AND TABLE B

TABLE A. INTERACTION OF PH AND A_w FOR CONTROL OF SPORES IN FOOD HEAT-TREATED TO DESTROY VEGETATIVE CELLS AND SUBSEQUENTLY PACKAGED			
A_w VALUES	<u>PH VALUES</u>		
	4.6 OR LESS	> 4.6 - 5.6	> 5.6
≤ 0.92	NON-PHF*/NON-TCS FOOD**	NON-PHF/NON-TCS FOOD	NON-PHF/NON-TCS FOOD
> 0.92 - .95	NON-PHF/NON-TCS FOOD	NON-PHF/NON-TCS FOOD	PA***
> 0.95	NON-PHF/NON-TCS FOOD	PA	PA

* PHF MEANS POTENTIALLY HAZARDOUS FOOD

** TCS FOOD MEANS TIME/TEMPERATURE CONTROL FOR SAFETY FOOD

*** PA MEANS PRODUCT ASSESSMENT REQUIRED

TABLE B. INTERACTION OF PH AND A_w FOR CONTROL OF VEGETATIVE CELLS AND SPORES IN FOOD NOT HEAT-TREATED OR HEAT-TREATED BUT NOT PACKAGED

A _w VALUES	<u>PH VALUES</u>			
	< 4.2	4.2 - 4.6	> 4.6 - 5.0	> 5.0
< 0.88	NON-PHF*/ NON-TCS FOOD**	NON-PHF/ NON-TCS FOOD	NON-PHF/ NON-TCS FOOD	NON-PHF/ NON-TCS FOOD
0.88 - 0.90	NON-PHF/ NON-TCS FOOD	NON-PHF/ NON-TCS FOOD	NON-PHF/ NON-TCS FOOD	PA***
> 0.90 - 0.92	NON-PHF/ NON-TCS FOOD	NON-PHF/ NON-TCS FOOD	PA	PA
> 0.92	NON-PHF/ NON-TCS FOOD	PA	PA	PA

* PHF MEANS POTENTIALLY HAZARDOUS FOOD

** TCS FOOD MEANS TIME/TEMPERATURE CONTROL FOR SAFETY FOOD

*** PA MEANS PRODUCT ASSESSMENT REQUIRED

The following is a limited list of specific food products that have been classified to be potentially hazardous.

1. Bacon - If it has not been fully cooked.
2. Balutes - Fertile eggs, generally chicken or duck eggs, which are incubated for a period of time shorter than is necessary for hatching. The developing embryo is incubated generally 14 to 18 days and is considered a delicacy by various ethnic populations when eaten raw or cooked.
3. Beans - All types of cooked beans.
4. Whipped Butter - Hazardous because of the apparent reduced microbiological safety factor created by whipping.
5. Cheese - Soft unripened cheese. Ripened, low moisture hard cheese such as wheels, flats, blocks or longhorns of cheddar cheese produced from pasteurized milk, when waxed or packaged in "shrink" wrapping with the wax or packaging intact, can be safely shipped or stored for a short period of time without refrigeration but it is not recommended. If wheels, flats, blocks,

longhorns, or any other forms of cheese have been damaged, cut and repackaged for display and/or sale, thereby exposing interior surfaces to possible contamination, the cut portions as well as the remaining cheese shall be held under refrigeration.

6. Coffee Creaming Agents - All non-dairy coffee creaming agents in liquid form, except aseptically processed ultra high temperature (UHT) liquid coffee creaming agents.
7. Cut Leafy Greens- Following 24 multi-state outbreaks between 1998 and 2008, cut leafy greens was added to the definition of potentially hazardous food requiring time-temperature control for safety (TCS). The term used in the definition includes a variety of cut lettuces and leafy greens. Raw agricultural commodities (RACs) that are not processed or cut on-site are excluded from the definition of cut leafy greens. Herbs such as cilantro or parsley are also not considered cut leafy greens. The pH, water activity, available moisture and nutrients of cut leafy greens supports the growth of foodborne pathogens and refrigeration at 41°F (5°C) or less inhibits growth and promotes general die off in some pathogens such as *E. coli* O157:H7, *Salmonella*, *E. coli* O157:H7 and *Listeria monocytogenes*, once attached to the surface or internalized into cut surfaces of leafy greens, are only marginally affected by chemical sanitizers.
8. Cut Tomatoes- Historically, uncooked fruits and vegetables, such as cut tomatoes, have been considered non-PHF unless they were epidemiologically implicated in foodborne illness outbreaks and are capable of supporting the growth of pathogenic bacteria in the absence of temperature control. The US Food and Drug Administration (FDA) has reported that since 1990, at least 12 multi-state foodborne illness outbreaks have been associated with different varieties of tomatoes and additionally, from 1998-2006, outbreaks associated with tomatoes made up 17% of the produce related outbreaks reported to FDA nationwide. *Salmonella* has been the pathogen of concern most often associated with tomato outbreaks.
9. Eggs - Cooked, cracked, fresh with outer shell removed, peeled hard-boiled eggs, and hard-boiled eggs with intact shells which have been hard-boiled and then cooled in liquid. Refrigeration of raw whole eggs in the shell is required.
10. Garlic - Garlic in oil products.
11. Mayonnaise or Other Acidified Salad Dressings - If the pH is above 4.6 and/or combined with other food products.
12. Onions- Cooked and dehydrated that have been reconstituted.
13. Pasta - All types that have been cooked.
14. Pastries - Meat, cheese and cream filled.
15. Pies - Meat, fish, poultry, natural cream, synthetic cream, custard, pumpkin and pies that are covered with toppings which will support microbial growth.
16. Potatoes - Baked, boiled or fried.
17. Rice - Boiled, steamed, fried, Spanish and cooked rice used in sushi.
18. Sour Cream - If the pH is above 4.6 and/or combined with other food products.
19. Soy Protein - Tofu and other moist soy protein products.
20. Seed Sprouts - All types.

FOODS WHICH ARE NOT POTENTIALLY HAZARDOUS ARE:

1. Hard-Boiled eggs with shells intact which have been air-dried; and
2. Foods which have been adequately commercially processed and remain in their unopened hermetically sealed container.

APPENDIX B - Safe Materials Colorado Pure Food and Drug Law

Sections 25-5-402 (3) and (12), C.R.S.

- (3) a. "Color additive" means a material which:
- (I.) Is a dye, pigment, or other substance made by a process of synthesis or similar artifice or extracted, isolated, or otherwise derived, with or without intermediate or final change of identity, from a vegetable, animal, mineral, or other source; and
 - (II.) When added or applied to a food, drug, or cosmetic or to the human body or any part thereof; is capable (alone or through reaction with other substance) of imparting color thereto; except that such term does not include any material which is exempted under the federal act.
- b. Nothing in this subsection (3) shall be construed to apply to any pesticide chemical, soil or plant nutrient, or other agricultural chemical solely because of its effect in aiding, retarding, or otherwise affecting, directly or indirectly, the growth or other natural physiological process or produce of the soil and thereby affecting its color, whether before or after harvest.
- (12) "Food additive" means any substance, the intended use of which results or may be reasonably expected to result, directly or indirectly, in its becoming a component or otherwise affecting the characteristics of any food (including any substance intended for use in producing, manufacturing, packing, processing, preparing, treating, packaging, transporting, or holding such substance is not generally recognized among experts qualified by scientific training and experience to evaluate its safety as having been adequately shown through scientific procedures or, in the case of a substance used in a food prior to January 1, 1958, through either scientific procedures or experience based on common use in food) to be safe under the conditions of its intended use. The term does not include:
- a. A pesticide chemical in or on a raw agricultural commodity;
 - b. A pesticide chemical to the extent that it is intended for use or is used in the production, storage, or transportation of any raw agricultural commodity;
 - c. A color additive; or
 - d. Any substance used in accordance with a sanction or approval granted prior to the enactment of the amendment to the federal act known as the "Food Additives Amendment of 1958," the Poultry Products Inspectional Act" (21 U.S.C. 451-470), or the "Meat Inspection Act of March 4, 1907," as amended and extended (21 U.S.C. 71-91)

APPENDIX C - Worksheets for Calculating Minimum Hot Water Requirements

The following worksheet is provided to assist operators in calculating hot water usage and sizing of the water heater system required for the operation.

What is the distance between the water heating system(s) and the fixture that is farthest from the heating system?

Fixture: _____ Feet from water heating system: _____

Standard Tank Type Systems:

I. Calculate Total Water Required By All Fixtures:

A. Three compartment sink calculation of water usage:

1. Measure dimensions, in inches, of each compartment, if compartments are not the same dimensions see note below.

Length = _____ Width = _____ Depth = _____

2. Insert measurements into equation:

$$\left(\frac{\text{length}}{\text{length}} \times \frac{\text{width}}{\text{width}} \times \frac{\text{depth}}{\text{depth}} \times 3 \times 0.375 \right) \div 2.31 = \text{water usage GPH}$$

Note: If all the compartment sizes of the sink are not the same, then 3 is taken out of the equation, and the above calculation is done for each compartment. The volumes are added to obtain the total gallons per hour of hot water used in the sink.

Enter number into the attached "Table to Calculate Total Water Required By All Fixtures," found on page C-4 .

B. Utensil soak sink

1. Measure dimensions, in inches, of the sink

Length = _____ Width = _____ Depth = _____ GPH

2. Insert measurements into equation:

$$\left(\frac{\text{length}}{\text{length}} \times \frac{\text{width}}{\text{width}} \times \frac{\text{depth}}{\text{depth}} \times .375 \right) \div 231 = \frac{\text{water usage}}{\text{water usage}}$$

Enter number into the attached “Table to Calculate Total Water Required By All Fixtures,” found on page C-4.

C. Dishmachine and conveyor pre-rinse water usage:

1. Use manufacturer’s rating in gallons per hour. Enter number into attached “Table to Calculate Total Water Required By All Fixtures,” found on page C-4.
2. Clothes washer water usage.
 - Use manufacturer’s rating: _____, or
 - 32 GPH for 9-12 pound washer, or
 - 42 GPH for 16 pound washer.

Enter number into the attached “Table to Calculate Total Water Required By All Fixtures,” found on page C-4 .

D. “Calculate Total Water Required By All Fixtures” and the number of fixtures in the operation to determine maximum hourly usage for each type of fixture in the operation.

Total water (GPH) required by all fixtures: _____ GPH.

II. Calculate Maximum Hourly Hot Water Usage

If gas water heater is used go to Step A; if electric, Step B.

A. Gas Water Heater: If a gas water heater is to be used, calculate the maximum hourly hot water usage for the facility by adjusting the total water required by all fixtures for altitude. The altitude adjustment is 4% per 1000 feet of elevation, or 20% at 5000 feet.

Use the following equations to determine the maximum hourly hot water usage when a gas powered water heater is to be used:

$$\left(0.04 \times \frac{\text{elevation of facility}}{\text{elevation of facility}} \div 1000 \right) + 1 = \frac{\text{adjustment factor}}{\text{adjustment factor}}$$

$$\frac{\text{adjustment factor}}{\text{adjustment factor}} \times \frac{\text{total water required by all fixtures}}{\text{total water required by all fixtures}} = \frac{\text{maximum hourly hot water usage}}{\text{maximum hourly hot water usage}} \text{ GPH}$$

Example, if the total gallon per hour usage for an establishment at an elevation of 5000 feet is 100 GPH, the adjustment factor is 1.2. Therefore, a water heater with 120 GPH recovery rate would be required.

Use this value in the equation to calculate the minimum BTU rating of the water heater.

- B. Electric Water Heater: If an electric water heater is to be used, the maximum hourly usage for the operation is the same as the total water required by all fixtures. Use this value in the equation to calculate the minimum Kilowatt (KW) rating of the water heater.
- C. the value determined in Step A or B the minimum recovery rate of the water heater which should be provided for the facility.

III. Calculate the minimum BTU or Kilowatt rating of water heater:

- A. For gas water heater, calculate the minimum BTU rating:

$$\frac{(\text{max hourly usage as calculated above}) \times (100^{\circ}\text{F}^*) \times (8.33)}{.80 \text{ or use manufacturer's thermal efficiency}} = \text{minimum BTU rating}$$

- B. For electric water heater, calculate the minimum Kilowatt rating :

$$\frac{(\text{max hourly usage as calculated above}) \times (100^{\circ}\text{F}^*) \times (8.33)}{3412} = \text{minimum KW rating}$$

*If there is no high temperature dishwashing machine or other fixtures requiring input water temperature of 140°F (100°F rise) or more, then 80°F rise can be used.

- C. Select water heater based upon BTU or Kilowatt rating.

Make: _____ ; Model #: _____

BTU or Kilowatt Rating: _____

Recovery rate: _____ gallons per hour at 100°F rise at sea level.

- D. Heat reclaim systems:

Make: _____ ; Model #: _____

BTU Rating: _____

Recovery rate: _____ gallons per hour at 100°F rise at sea level.

Table to Calculate Total Water Required For All Fixtures.

Plumbing Fixture	Water Usage (gallons per hour)	Number of Fixtures	Maximum Hourly Water Usage Per Type of Fixture (gallon per hour)
<i>example: dishwashing machine</i>	<i>50</i>	<i>1</i>	<i>50</i>
<i>example: handsink(s)</i>	<i>5</i>	<i>4</i>	<i>(5 x 4 =) 20</i>
3-compartment sink			
3-compartment sink (bar)			
Utensil soak sink			
Dishmachine			
Dishwashing machine conveyor pre-rinse			
Clothes washer			
Hand operated pre-rinse sprayer*	32		
Hand washing sinks (including restrooms)*	5		
Mop/utility sinks	7		
Garbage can washer	35		
Showers*	14		
Hose bib used for cleaning	35		
Total water (GPH) required by all fixtures:			

*A hot water use reduction can be calculated for water saving devices used on hand operated pre-rinse sprayers, hand washing sinks and showers by doing the following calculations.

A. Water savings device. Obtain manufacturer's flow rate for each device. The manufacturer's flow rate must be less than what is listed below to be considered:

1. Hand operated pre-rinse sprayers with flow rate less than 3.5 GPM standard flow rate.

Make: _____ ; Model #: _____

Manufacturer's Flow Rating: _____ GPM

2. Hand washing sink faucet or aerator with flow rate less than 2.2 GPM standard flow rate.

Make: _____ ; Model #: _____

Manufacturer's Flow Rating: _____ GPM

3. Shower head with flow rate less than 2.5 GPM standard flow rate.

Make: _____ ; Model #: _____

Manufacturer's Flow Rating: _____ GPM

B. Use the following equation to determine the reduced hourly hot water usage for each of the three types of fixtures:

$$\left(\frac{\text{_____}}{\text{_____}} \times \text{_____} \right) \div \text{_____} = \text{_____}$$

manufacturer's flow
use value rate

water use value from
Table to Calculate Total
Water Required for All
Fixtures **on page C-4**

GPM standard flow
rate

new water
to be entered into Table
to Calculate Total Water
Required for All Fixtures **on
page C-4)**

Example calculation for a hand washing sink that has an aerator with a manufacturer's flow rate of 0.5 gpm:

$$\left(\frac{\underline{0.5 \text{ GPM}}}{\underline{\text{GPH}}} \times \underline{5 \text{ GPH}} \right) \div \underline{2.2 \text{ GPM}} = \underline{1.14}$$

manufacturer's flow
use value rate

water use value from
table to Calculate Total
Water Required for All
Fixtures **on page C-4**

GPM standard flow
rate

new water
to be entered into table
to Calculate Total Water
Required for All Fixtures **on
page C-4)**

1.14 GPH would be entered into the "Table to Calculate Total Water Required for All Fixtures," found on page Appendix C-4 in place of the 5 GPH for hand washing sinks.

Requirements for Dishwashing Machine Booster Heaters:

I. Dishwashing Machine

Manufacturer: _____

Model Number: _____

Final Sanitizing Rinse Cycle Gallons Per Hour Water Consumption: _____ GPH

II. Calculate the minimum BTU or Kilowatt rating of the booster heater:

A. For gas booster heater, calculate the minimum BTU rating:

$(\text{Gallons Per Hour Water Consumption}) \times (40^\circ\text{F}) \times (8.33) = \text{minimum BTU rating}$
.80 or use manufacturer's thermal efficiency

B. For electric water heater, calculate the minimum Kilowatt rating :

$(\text{Gallons Per Hour Water Consumption}) \times (40^\circ\text{F}) \times (8.33) = \text{minimum KW rating}$
3412

C. Select booster heater based upon BTU or Kilowatt rating. The booster heater must have recovery rate greater than the dishwashing machine's final rinse water consumption.

Make: _____ ; Model #: _____

BTU or Kilowatt Rating: _____

Recovery rate: _____ gallons per hour at 40°F rise at sea level.

Tankless or Instantaneous Systems

I. Heater Specifications:

Manufacturer*: _____

Model Number: _____

Flow Rate in Gallons Per Minute (GPM) at 100°F rise**: _____ GPM

BTU Rating: _____ BTU***

*Units must be designed for commercial use.

** If there are no high temperature dishwashing machine or other fixtures requiring input water temperature of 140°F (100°F rise) or more, then 80°F rise can be used.

***Electric units will only be approved as a dedicated hot water supply to hand washing sinks.

III. Calculate the total hot water demand flow rate in Gallons Per Minute (GPM) using this table.

PLUMBING FIXTURE	WATER USAGE (GALLONS PER MINUTE)	NUMBER OF FIXTURES	WATER DEMAND FLOW RATE IN GALLONS PER MINUTE
<i>EXAMPLE: DISHWASHING MACHINE † HOBART AM 14</i>	<i>8.0</i>	<i>1</i>	<i>(8.0 × 1) = 8.0</i>
<i>EXAMPLE: HANDSINK(S)</i>	<i>0.5</i>	<i>4</i>	<i>(0.5 × 4) = 2.0</i>
3-COMPARTMENT SINK*	2.0 FOR EACH FAUCET		
3-COMPARTMENT SINK (BAR)*	2.0 FOR EACH FAUCET		
UTENSIL SOAK SINK	1.0		
DISHWASHING MACHINE †			
DISHWASHING MACHINE CONVEYOR PRE-RINSE †			
CLOTHES WASHER	2.0		
HAND OPERATED PRE-RINSE SPRAYER †	2.0		
FOOD PREPARATION SINK(S)	1.0		
HAND WASHING SINKS (INCLUDING RESTROOMS) *	0.5		
MOP/UTILITY SINKS	2.0		
GARBAGE CAN WASHER	1.0		
SHOWERS †	1.0		
HOSE BIB USED FOR CLEANING	5.0		
TOTAL WATER DEMAND (GPM) REQUIRED:			

*A flow rate reduction can be used for low flow water faucets installed on 3-compartment sinks, hand operated pre-rinse sprayers, food preparation sinks, hand washing sinks and showers by entering the manufacturer's flow rate listed for the faucet or faucet's aerator.

†Use manufacturer's flow rate in GPM for specific make and model of dishwashing machine or shower head.

- IV. Calculate the maximum flow rate for the establishment. The thermal efficiency of the water heating units must be adjusted for altitude. The altitude adjustment is 4% per 1000 feet of elevation, or 20% at 5000 feet.

Use the following equations to determine the establishment's maximum flow rate in GPM:

$$(0.04 \times \frac{\text{elevation of facility}}{1000} + 1) = \text{adjustment factor}$$

$$\frac{\text{adjustment factor}}{\text{total water demand for all fixtures calculated in III}} \times \text{total water demand for all fixtures calculated in III} = \text{maximum GPM hot water usage}$$

Use calculated maximum GPM hot water usage value in this equation to determine the minimum number of heating units that will be required in IV below.

- V. Determine the number of heating units that will be needed to meet the required flow rate.

$$\frac{\text{maximum demand (GPM) calculated in PART III}}{\text{manufacturer's flow rate in GPM @ 100°F}} = \text{number of heating units required*}$$

*Multiple units must be installed and plumbed to operate in a parallel configuration.

- VI. Storage Tank Sizing:

If a dishwashing machine(s) is to be installed the instantaneous water heating system must include a storage tank. The storage tank must be at least 25 gallons or at least 25% of the gallons per hour (GPH) demand of the dishwashing machine(s). The larger value of the two is the required storage tank size.

Dishwashing Machine*

Manufacturer: _____

Model Number: _____

Gallons Per Hour Water Consumption: _____ x 0.25 = _____
storage tank capacity
in gallons

Calculated Storage Tank Capacity: _____ vs. 25 Gallons Storage Tank

Enter the larger of the two: _____ Required Storage Tank Capacity**

*High temperature, heat sanitizing dishwashing machines must be provided with a separate booster heater. Use of an instantaneous unit is not allowed for use as a booster heater.

**The storage tank must be installed in the hot water supply line located between the heater unit(s) and the hot water distribution line. A recirculation line, equipped with a recirculation pump and aquastat, (water thermostat) must be installed at the storage tank to assure the water in the tank remains at the appropriate temperature (120-140°F). The recirculation line must be connected between the storage tank and the cold water supply line at the heater unit(s).

APPENDIX D – Specific Usage Additives

173.310 Boiler water additives.

Boiler water additives may be safely used in the preparation of steam that will contact food, under the following conditions:

- A. The amount of additive is not in excess of that required for its functional purpose, and the amount of steam in contact with food does not exceed that required to produce the intended effect in or on the food.
- B. The compounds are prepared from substances identified in paragraphs (C) and (D) of this section, and are subject to the limitations, if any, prescribed:
- C. List of substances:

Substances	Limitations
<p>Acrylamide-sodium acrylate resin.....</p> <p>Acrylic acid/2-acrylamido-2-methyl propane sulfonic acid copolymer having a minimum weight average molecular weight of 9,900 and a minimum number average molecular weight of 5,700 as determined by a method entitled “Determination of Weight Average and Number Average Molecular Weight of 60/40 AA/AMPS” (October 23, 1987), which is incorporated by reference in accordance with 5 U.S.C. 552(a). Copies may be obtained from the Center for Food Safety and Applied Nutrition (HFS-200), Food and Drug Administration, 200 C St. SW., Washington, DC 20204, or may be examined at the Office of the Federal Register, 800 North Capitol Street, NW., suite 700, Washington, DC.</p> <p>Ammonium alginate.</p> <p>Cobalt sulfate (as catalyst).</p> <p>1-hydroxyethylidene-1, 1-diphosphonic acid (CAS Reg. No. 2809-21-4) and its sodium and potassium salts.</p> <p>Lignosulfonic acid.</p>	<p>Contains not more than 0.05 percent by weight of acrylamide monomer.</p> <p>Total not to exceed 20 parts per million (active) in boiler feedwater.</p>
<p>Monobutyl ethers of polyethylene-polypropylene glycol produced by random condensation of a 1:1 mixture by weight of ethylene oxide and propylene oxide with butanol.</p> <p>Poly(acrylic acid-co-hypophosphite), sodium salt (CAS Reg. No. 71050-62-9), produced from a 4:1 to a 16:1 mixture by weight of acrylic acid and sodium hypophosphite.</p> <p>Polyethylene glycol</p>	<p>Minimum mol. Wt. 1,500.</p> <p>Total not to exceed 1.5 parts per million in boiler feed water. Copolymer contains not more than 0.5 percent by weight of acrylic acid monomer (dry weight basis).</p> <p>As defined in 172.820 of this chapter.</p>

Substances	Limitations
<p>Polymaleic acid [CAS Reg. No. 26099-09-2], and/or its sodium salt. [CAS Reg. No. 30915-61-8 or CAS Reg. No. 70247-90-4].</p> <p>Polyoxypropylene glycol</p> <p>Potassium carbonate.</p> <p>Potassium tripolyphosphate.</p> <p>Sodium acetate.</p> <p>Sodium alginate.</p> <p>Sodium aluminate.</p> <p>Sodium carbonate.</p>	<p>Total not to exceed 1 part per million in boiler feed water (calculated as the acid).</p> <p>Minimum mol wt. 1,000.</p>
<p>Sodium carboxy-methylcellulose</p>	<p>Contains not less than 95 percent sodium carboxymethylcellulose on a dry-weight basis, with maximum substitution of 0.9 carboxymethylcellulose groups per anhydroglucose unit, and with a minimum viscosity of 15 centipoises for 2 percent by weight aqueous solution at 25°C; by method prescribed in the "Food Chemicals Codex," 3d Ed. (1981), pp. 280-282, which is incorporated by reference. Copies may be obtained from the National Academy Press, 2101 Constitution Ave. NW., Washington, DC 20418, or may be examined at the Office of the Federal Register, 800 North Capitol Street, NW., suite 700, Washington, DC 20408</p>
<p>Sodium glucoheptonate</p> <p>Sodium hexametaphosphate.</p> <p>Sodium humate.</p> <p>Sodium hydroxide.</p> <p>Sodium lignosulfonate.</p> <p>Sodium metabisulfite.</p> <p>Sodium metasilicate.</p> <p>Sodium nitrate.</p> <p>Sodium phosphate (mono-, di-, tri-).</p> <p>Sodium polyacrylate.</p> <p>Sodium polymethacrylate.</p> <p>Sodium silicate.</p> <p>Sodium sulfate.</p> <p>Sodium sulfite (neutral or alkaline).</p> <p>Sodium tripolyphosphate.</p> <p>Tannin (including quebracho extract).</p> <p>Tetrasodium EDTA.</p> <p>Tetrasodium pyrophosphate.</p>	<p>Less than 1 part per million cyanide in the sodium glucoheptonate.</p>

D. Substances used alone or in combination with substances in paragraph (C) of this section:

Substances	Limitations
Cyclohexylamine	Not to exceed 10 parts per million in steam, and excluding use of such steam in contact with milk and milk products.
Diethylaminoethanol	Not to exceed 15 parts per million in steam, and excluding use of such steam in contact with milk and milk products.
Hydrazine	Zero in steam.
Morpholine	Not to exceed 10 parts per million in steam, and excluding use of such steam in contact with milk and milk products.
Octadecylamine	Not to exceed 3 parts per million in steam, and excluding use of such steam in contact with milk and milk products
Trisodium nitrilotriacetate	Not to exceed 5 parts per million in boiler feedwater; not to be used where steam will be in contact with milk and milk products.

E. To assure safe use of the additive, in addition to the other information required by the Act, the label or labeling shall bear:

1. The common or chemical name or names of the additive or additives.
2. Adequate directions for use to assure compliance with all the provisions of this section.

APPENDIX E –LUBRICANTS

21 CFR Section 178.3570 (2009) Lubricants With Incidental Food Contact

Lubricants with incidental food contact may be safely used on machinery used for producing, manufacturing, packing, processing, preparing, treating, packaging, transporting, or holding food, subject to the provisions of this section.

- A. The lubricants are prepared from one or more of the following substances.
1. Substances generally recognized as safe for use in food.
 2. Substances used in accordance with the provisions of a prior sanction or approval.
 3. Substances identified in this paragraph (A)(3).

Substances	Limitations
Aluminum stearoyl benzoyl hydroxide	For use only as a thickening agent in mineral oil lubricants at a level not to exceed 10 pct by weight of the mineral oil.
BHA.	
BHT.	
α -Butyl-omega-hydroxypoly(oxyethylene) poly(oxypropylene) produced by random condensation of a 1:1 mixture by weight of ethylene oxide and propylene oxide with butanol; minimum molecular weight 1,500; Chemical Abstracts Service Registry No. 9038-95-3.	Addition to food not to exceed 10 parts per million.
α -Butyl-omega-hydroxypoly(oxypropylene); minimum molecular weight 1,500; Chemical Abstracts Service Registry No. 9003-13-8.	Do.
Castor oil	Do.
Castor oil, dehydrated	Do.
Castor oil, partially dehydrated	Do.
Dialkyldimethylammonium aluminum silicate (CAS Reg. No. 68953-58-2), which may contain up to 7 percent by weight 1,6-hexanediol (CAS Reg. No. 629-11-8), where the alkyl groups are derived from hydrogenated tallow fatty acids (C ₁₄ -C ₁₈) and where the aluminum silicate is derived from bentonite.	For use only as a wetting agent in mineral oil lubricants at a level not to exceed 15 percent by weight of the mineral oil.
Dimethylpolysiloxane (viscosity greater than 300 centistokes).	Addition to food not to exceed 1 part per million.
Disodium decanedioate (CAS Reg. No. 17265-14-4).	For use as a corrosion inhibitor or rust preventative in mineral oil-bentonite lubricants at a level not to exceed 2 percent by weight of the grease.

Substances	Limitations
<p>Disodium EDTA (CAS Reg. No. 139-33-3)</p> <p>Ethoxylated resin phosphate ester mixture consisting of the following compounds:</p> <ol style="list-style-type: none"> 1. Poly(methylene-p-tert-butyl-phenoxy) poly(oxyethylene) mixture of dihydrogen phosphate and monohydrogen phosphate esters (0-40 percent of the mixture). The resin is formed by condensation of 1 mole of p-tert-butylphenol with 2 to 4 moles of formaldehyde and subsequent ethoxylation with 4 to 12 moles of ethylene oxide; 2. Poly(methylene-p-nonylphenoxy) poly(oxyethylene) mixture of dihydrogen phosphate and monohydrogen phosphate esters (0-40 percent of the mixture). The resin is formed by condensation of 1 mole of p-nonylphenol with 2 to 4 moles of formaldehyde and subsequent ethoxylation with 4 to 12 moles of ethylene oxide; and. 3. N-Tridecyl alcohol mixture of dihydrogen phosphate and monohydrogen phosphate esters (40 to 80 percent of the mixture; CAS Reg. No. 56831-62-0). <p>Fatty acids derived from animal or vegetable sources, and the hydrogenated forms of such fatty acids.</p> <p>2-(8-Heptadecenyl)-4,5-dihydro-1 H-imidazole-1-ethanol(CAS Reg. No. 95-38-5).</p> <p>Hexamethylenebis(3,5-di-tert-butyl-4-hydroxyhydrocinnamate) (CAS Reg. No. 35074-77-2).</p>	<p>For use only as a chelating agent and sequestant at a level not to exceed 0.06 percent by weight of lubricant at final use dilution.</p> <p>For use only as a surfactant to improve lubricity in lubricating fluids complying with this section at a level not to exceed 5 percent by weight of the lubricating fluid.</p> <p>For use at levels not to exceed 0.5 percent by weight of the lubricant.</p> <p>For use as an antioxidant at levels not to exceed 0.5 percent by weight of the lubricant.</p>
<p>α-Hydro-omega-hydroxypoly (oxyethylene) poly(oxypropylene) produced by random condensation of mixtures of ethylene oxide and propylene oxide containing 25 to 75 percent by weight of ethylene oxide; minimum molecular weight 1,500; Chemical Abstracts Service Registry No. 9003-11-6.</p> <p>12-Hydroxystearic acid.</p>	<p>Addition to food not to exceed 10 parts per million.</p>
<p>Isopropyl oleate</p>	<p>For use only as an adjuvant (to improve lubricity) in mineral oil lubricants.</p>
<p>Magnesium ricinoleate</p>	<p>For use only as an adjuvant in mineral oil lubricants at a level not to exceed 10 percent by weight of the mineral oil.</p>

Substances	Limitations
<p>Mineral oil</p> <p>N-Methyl-N-(1-oxo-9-octadecenyl)glycine (CAS Reg. No. 110-25-8).</p> <p>N-phenylbenzenamine, reaction products with 2,4,4-trimethylpentene (CAS Reg. No. 68411-46-1).</p> <p>Petrolatum</p> <p>Phenyl-α-and/or phenyl-β-naphthylamine</p> <p>Phosphoric acid, mono- and dihexyl esters, compounds with tetramethylnonylamines and C₁₁₋₁₄ alkylamines.</p> <p>Phosphoric acid, mono- and diisooctyl esters, reacted with tertalkyl and (C₁₂-C₁₄) primary amines (CAS Reg. No. 68187-67-7).</p> <p>Polyurea, having a nitrogen content of 9-14 percent based on the dry polyurea weight, produced by reacting tolylene diisocyanate with tall oil fatty acid (C₁₆ and C₁₈) amine and ethylene diamine in a 2:2:1 molar ratio.</p> <p>Polybutene (minimum average molecular weight 80,000)</p>	<p>Addition to food not to exceed 10 parts per million.</p> <p>For use as a corrosion inhibitor at levels not to exceed 0.5 percent by weight of the lubricant.</p> <p>For use only as an antioxidant at levels not to exceed 0.5 percent by weight of the lubricant.</p> <p>Complying with 178.3700. Addition to food not to exceed 10 parts per million.</p> <p>For use only, singly or in combination, as antioxidant in mineral oil lubricants at a level not to exceed a total of 1 percent by weight of the mineral oil.</p> <p>For use only as an adjuvant at levels not to exceed 0.5 percent by weight of the lubricant.</p> <p>For use only as a corrosion inhibitor or rust preventative in lubricants at a level not to exceed 0.5 percent by weight of the lubricant.</p> <p>For use only as an adjuvant in mineral oil lubricants at a level not to exceed 10 percent by weight of the mineral oil.</p> <p>Addition to food not to exceed 10 parts per million</p>
<p>Polybutene, hydrogenated; complying with the identity prescribed under 178.3740.</p> <p>Polyethylene</p> <p>Polyisobutylene (average molecular weight 35,000-140,000 (Flory)).</p> <p>Sodium nitrite</p> <p>Tetrakis{methylene(3,5-di-tert-butyl-4-hydroxyhydro-cinnamate)}methane (CAS Reg. No. 6683-19-8).</p> <p>Thiodiethylenebis (3,5-di-tert-butyl-4-hydroxyhydrocinnamate) (CAS Reg. No. 41484-35-9).</p>	<p>Do.</p> <p>Do.</p> <p>For use only as a thickening agent in mineral oil lubricants.</p> <p>For use only as a rust preventative in mineral oil lubricants at a level not to exceed 3 percent by weight of the mineral oil.</p> <p>For use only as an antioxidant at levels not to exceed 0.5 percent by weight of the lubricant.</p> <p>For use as an antioxidant at levels not to exceed 0.5 percent by weight of the lubricant.</p>
<p>Triphenyl phosphorothionate (CAS Reg. No. 597-82-0)</p>	<p>For use as an adjuvant in lubricants herein listed at a level not to exceed 0.5 percent by weight of the lubricant.</p>
<p>Tris(2,4-di-tert-butylphenyl)phosphite (CAS Reg No. 31570-04-4).</p>	<p>For use only as a stabilizer at levels not to exceed 0.5 percent by weight of the lubricant.</p>

Substances	Limitations
Thiodiethylenebis(3,5-di-tert-butyl-4-hydroxy-hydro-cinnamate)(CAS Reg. No. 41484-35-9).	For use as an antioxidant at levels not to exceed 0.5 percent by weight of the lubricant.
Zinc sulfide	For use at levels not to exceed 10 percent by weight of the lubricant.

- B. The lubricants are used on food processing equipment as a protective antirust film, as a release agent on gaskets or seals of tank closures, and as a lubricant for machine parts and equipment in locations in which there is exposure of the lubricated part to food. The amount used is the minimum required to accomplish the desired technical effect on the equipment, and the addition to food of any constituent identified in this section does not exceed the limitations prescribed.

- C. Any substance employed in the production of the lubricants described in this section that is the subject of a regulation in parts 174, 175, 176, 177, 178 and 179.45 of this chapter conforms with any specification in such regulation.

APPENDIX F - SANITIZERS

Refer to 40 CFR § 180.940, (2010) Sanitizing solutions

APPENDIX G - HACCP Guidelines

1. Introduction to HACCP

A. What is HACCP and how can it be used by operators and regulators of retail food and food service establishments?

Hazard Analysis and Critical Control Point (HACCP) is a systematic approach to identifying, evaluating, and controlling food safety hazards. Food safety hazards are biological, chemical, or physical agents that are reasonably likely to cause illness or injury in the absence of their control. Because a HACCP program is designed to ensure that hazards are prevented, eliminated, or reduced to an acceptable level before a food reaches the consumer, it embodies the preventive nature of "active managerial control."

Active managerial control through the use of HACCP principles is achieved by identifying the food safety hazards attributed to products, determining the necessary steps that will control the identified hazards, and implementing on-going practices or procedures that will ensure safe food.

Like many other quality assurance programs, HACCP provides a common-sense approach to identifying and controlling problems that are likely to exist in an operation. Consequently, many food safety management systems at the retail level already incorporate some, if not all, of the principles of HACCP. Combined with good basic sanitation, a solid employee training program, and other prerequisite programs, a food safety management system based on HACCP principles will prevent, eliminate, or reduce the occurrence of foodborne illness risk factors that lead to out-of-control hazards.

HACCP represents an important tool in food protection that small independent businesses as well as national companies can use to achieve active managerial control of risk factors. The Food Code requires a comprehensive HACCP plan when conducting certain specialized processes at retail such as when a variance is granted or when a reduced oxygen packaging method is used. However, in general, the implementation of HACCP at the retail level is voluntary. FDA endorses the voluntary implementation of food safety management systems based on HACCP principles as an effective means for controlling the occurrence of foodborne illness risk factors that result in out-of-control hazards.

While the operator is responsible for developing and implementing a system of controls to prevent foodborne illness risk factors, the role of the regulator is to assess whether the system the operator has in place is achieving control of foodborne illness risk factors. Using HACCP principles during inspections will enhance the effectiveness of routine inspections by incorporating a risk-based approach. This helps inspectors focus their inspection on evaluating the effectiveness of food safety management systems implemented by industry to control foodborne illness risk factors.

For regulatory program managers, the use of risk-based inspection methodology based on HACCP principles is a viable and practical option for evaluating the degree of active managerial control operators have over the foodborne illness risk factors.

B. **What are the Seven HACCP Principles?**

In November 1992, the National Advisory Committee on Microbiological Criteria for Foods (NACMCF) defined seven widely accepted HACCP principles that explained the HACCP process in great detail. In 1997, NACMCF reconvened to review the 1992 document and compare it to current HACCP guidance prepared by the CODEX Committee on Food Hygiene. Based on this review, NACMCF again endorsed HACCP and defined HACCP as a systematic approach to the identification, evaluation, and control of food safety. Based on a solid foundation of prerequisite programs to control basic operational and sanitation conditions, the following seven basic principles are used to accomplish this objective:

1. Principle 1: Conduct a hazard analysis
2. Principle 2: Determine the critical control points (CCPs)
3. Principle 3: Establish critical limits
4. Principle 4: Establish monitoring procedures
5. Principle 5: Establish corrective actions
6. Principle 6: Establish verification procedures
7. Principle 7: Establish record-keeping and documentation procedures.

This appendix will provide a brief overview of each of the seven principles of HACCP. A more comprehensive discussion of these principles is available from FDA by accessing the [NACMCF guidance document](#)⁴. Following the overview, a practical scheme for applying and implementing the HACCP principles in retail and food service establishments is presented.

C. **What are Prerequisite Programs?**

In order for a HACCP system to be effective, a strong foundation of procedures that address the basic operational and sanitation conditions within an operation must first be developed and implemented. These procedures are collectively termed "prerequisite programs." When prerequisite programs are in place, more attention can be given to controlling hazards associated with the food and its preparation. Prerequisite programs may include such things as:

- Vendor certification programs
- Training programs
- Allergen management
- Buyer specifications
- Recipe/process instructions
- First-In-First-Out (FIFO) procedures
- Other Standard Operating Procedures (SOPs).

Basic prerequisite programs should be in place to:

- Protect products from contamination by biological, chemical, and physical food safety hazards
- Control bacterial growth that can result from temperature abuse
- Maintain equipment.

Additional information about prerequisite programs and the types of activities usually included in them can be found in the FDA's Retail HACCP manuals discussed later in this Appendix or by accessing the NACMCF guidance document on the FDA Web Page.

2. The HACCP Principles

A. Principle #1: Conduct a Hazard Analysis

1. What is a food safety hazard?

A hazard is a biological, chemical, or physical property that may cause a food to be unsafe for human consumption.

2. What are biological hazards?

Biological hazards include bacterial, viral, and parasitic microorganisms. See Table 1 in this Appendix for a listing of selected biological hazards. Bacterial pathogens comprise the majority of confirmed foodborne disease outbreaks and cases. Although cooking destroys the vegetative cells of foodborne bacteria to acceptable levels, spores of spore-forming bacteria such as *Bacillus cereus*, *Clostridium botulinum*, and *Clostridium perfringens* survive cooking and may germinate and grow if food is not properly cooled or held after cooking. The toxins produced by the vegetative cells of *Bacillus cereus*, *Clostridium botulinum*, and *Staphylococcus aureus* may not be destroyed to safe levels by reheating. Post-cook recontamination with vegetative cells of bacteria such as *Salmonellae* and *Campylobacter jejuni* is also a major concern for operators of retail and food service establishments.

Viruses such as norovirus, hepatitis A, and rotavirus are directly related to contamination from human feces. Recent outbreaks have also shown that these viruses may be transmitted via droplets in the air. In limited cases, foodborne viruses may occur in raw commodities contaminated by human feces (e.g., shellfish harvested from unapproved, polluted waters). In most cases, however, contamination of food by viruses is the result of cross-contamination by ill food employees or unclean equipment and utensils. Unlike bacteria, a virus cannot multiply outside of a living cell. Cooking as a control for viruses may be ineffective because many foodborne viruses seem to exhibit heat resistance exceeding cooking temperature requirements, under laboratory conditions. Obtaining food from approved sources, practicing no bare hand contact with ready-to-eat food as well as proper handwashing, and implementing an employee health policy to restrict or exclude ill employees are important control measures for viruses.

Parasites are most often animal host-specific, but can include humans in their life cycles. Parasitic infections are commonly associated with undercooking meat products or cross-contamination of ready-to-eat food with raw animal foods, untreated water, or contaminated equipment or utensils. Like viruses, parasites do not grow in food, so control is focused on destroying the parasites and/or preventing their introduction. Adequate cooking destroys parasites. In addition, parasites in fish to be consumed raw or undercooked can also be destroyed by

effective freezing techniques. Parasitic contamination by ill employees can be prevented by proper handwashing, no bare hand contact with ready-to-eat food, and implementation of an employee health policy to restrict or exclude ill employees.

Appendix G, Table 1. Selected Biological Hazards Found at Retail, Associated Foods, and Control Measures		
Hazard	Associated Foods	Control Measures
Bacteria Bacillus cereus(intoxication caused by heat stable, preformed emetic toxin and infection by heat labile, diarrheal toxin)	Meat, poultry, starchy foods (rice, potatoes), puddings, soups, cooked vegetables	Cooking, cooling, cold holding, hot holding
Campylobacter jejuni	Poultry, raw milk	Cooking, handwashing, prevention of cross-contamination
Clostridium botulinum	Vacuum-packed foods, reduced oxygen packaged foods, under-processed canned foods, garlic-in-oil mixtures, time/temperature abused baked potatoes/sautéed onions	Thermal processing (time + pressure), cooling, cold holding, hot holding, acidification and drying, etc.
Clostridium perfringens	Cooked meat and poultry, Cooked meat and poultry products including casseroles, gravies	Cooling, cold holding, reheating, hot holding
E. coli O157:H7 (other shiga toxin-producing E. coli)	Raw ground beef, raw seed sprouts, raw milk, unpasteurized juice, foods contaminated by infected food workers via fecal-oral route	Cooking, no bare hand contact with RTE foods, employee health policy, handwashing, prevention of cross-contamination, pasteurization or treatment of juice

	Listeria monocytogenes	Raw meat and poultry, fresh soft cheese, pâté, smoked seafood, deli meats, deli salads	Cooking, date marking, cold holding, handwashing, prevention of cross-contamination
	Salmonella spp.	Meat and poultry, seafood, eggs, raw seed sprouts, raw vegetables, raw milk, unpasteurized juice	Cooking, use of pasteurized eggs, employee health policy, no bare hand contact with RTE foods, handwashing, pasteurization or treatment of juice
	Shigella spp.	Raw vegetables and herbs, other foods contaminated by infected workers via fecal-oral route	Cooking, no bare hand contact with RTE foods, employee health policy, handwashing
	Staphylococcus aureus(preformed heat stable toxin)	RTE PHF foods touched by bare hands after cooking and further time/temperature abused	Cooling, cold holding, hot holding, no bare hand contact with RTE food, handwashing
	Vibrio spp.	Seafood, shellfish	Cooking, approved source, prevention of cross-contamination, cold holding
Parasites	Anisakis simplex	Various fish (cod, haddock, fluke, pacific salmon, herring, flounder, monkfish)	Cooking, freezing
	Taenia spp.	Beef and pork	Cooking
	Trichinella spiralis	Pork, bear, and seal meat	Cooking

Viruses	Hepatitis A and E	Shellfish, any food contaminated by infected worker via fecal-oral route	Approved source, no bare hand contact with RTE food, minimizing bare hand contact with foods not RTE, employee health policy, handwashing
	Other Viruses (Rotavirus, Norovirus, Reovirus)	Any food contaminated by infected worker via fecal-oral route	No bare hand contact with RTE food, minimizing bare hand contact with foods not RTE, employee health policy, handwashing

RTE = ready-to-eat

PHF = potentially hazardous food (time/temperature control for safety food)

3. What are Chemical Hazards?

Chemical hazards may be naturally occurring or may be added during the processing of food. High levels of toxic chemicals may cause acute cases of foodborne illness, while chronic illness may result from low levels.

The Code of Federal Regulations⁵, Title 21 Food and Drugs, provides guidance on naturally occurring poisonous or deleterious substances, e.g., 21 CFR Parts 109 Unavoidable Contaminants in Food for Human Consumption and Food Packaging Material, and 184 Direct Food Substances Affirmed as Generally Recognized as Safe. The CFR also provide allowable limits for many of the chemicals added during processing, e.g., 21 CFR Part 172 Food Additives Permitted for Direct Addition to Food For Human Consumption.

FDA's Compliance Policy Guidelines also provide information on naturally occurring chemicals. See Chapter 5 - Foods, Colors and Cosmetics⁶. Examples include sections:

- 540.600 Fish, Shellfish, Crustaceans, and Other Aquatic Animals - Fresh, Frozen or Processed – Methyl Mercury,
- 555.400 Foods - Adulteration with Aflatoxin, and
- 570.200 Aflatoxin in Brazil Nuts, .375 Peanuts and Peanut Products, and .500 Pistachio Nuts.

Table 2 of this Appendix provides additional examples of chemical hazards, both naturally occurring and added.

4. Food Allergens As Food Safety Hazards

Recent studies indicate that over 11 million Americans suffer from one or more food allergies. A food allergy is caused by a naturally-occurring protein in a food or a food ingredient, which is referred to as an "allergen." For unknown reasons, certain individuals produce immunoglobulin E (IgE) antibodies specifically directed to food allergens. When these sensitive individuals ingest sufficient concentrations of foods containing these allergens, the allergenic proteins interact

with IgE antibodies and elicit an abnormal immune response. A food allergic response is commonly characterized by hives or other itchy rashes, nausea, abdominal pain, vomiting and/or diarrhea, wheezing, shortness of breath, and swelling of various parts of the body. In severe cases, anaphylactic shock and death may result.

Many foods, with or without identifiable allergens, have been reported to cause food allergies. However, FDA believes there is scientific consensus that the following foods can cause a serious allergic reaction in sensitive individuals; these foods account for 90% or more of all food allergies:

- Milk
- Egg
- Fish (such as bass, flounder, or cod)
- Crustacean shellfish (such as crab, lobster, or shrimp)
- Tree nuts (such as almonds, pecans, or walnuts)
- Wheat
- Peanuts
- Soybeans.

Consumers with food allergies rely heavily on information contained on food labels to avoid food allergens. Each year, FDA receives reports from consumers who have experienced an adverse reaction following exposure to a food allergen. Frequently, these reactions occur either because product labeling does not inform the consumer of the presence of the allergenic ingredient in the food or because of the cross-contact of a food with an allergenic substance not intended as an ingredient of the food during processing and preparation.

In August 2004, the Food Allergen Labeling and Consumer Protection Act (Public Law 108-282, Title II) was enacted, which defines the term "major food allergen." The definition of "major food allergen" adopted for use in the Food Code (see paragraph 1-201.10(B)) is consistent with the definition in the new law. The following requirements are included in the new law:

- For foods labeled on or after January 1, 2006, food manufacturers must identify in plain language on the label of the food any major food allergen used as an ingredient in the food, including a coloring, flavoring, or incidental additive.
- FDA is to conduct inspections to ensure that food facilities comply with practices to reduce or eliminate cross-contact of a food with any major food allergens that are not intentional ingredients of the food.
- Within 18 months of the date of enactment of the new law (i.e., by February 2, 2006), FDA must submit a report to Congress that analyzes the results of its food inspection findings and addresses a number of specific issues related to the production, labeling, and recall of foods that contain an undeclared major food allergen.
- Within 2 years of the date of enactment of the new law (i.e., by August 2, 2006), FDA must issue a proposed rule, and within 4 years of the date of

enactment of the new law (i.e., by August 2, 2008), FDA must issue a final rule to define and permit the use of the term "gluten-free" on food labeling.

- FDA is to work in cooperation with the Conference for Food Protection (CFP) to pursue revision of the Food Code to provide guidelines for preparing allergen-free foods in food establishments.

Appendix G, Table 2. Common Chemical Hazards at Retail, Along with Their Associated Foods and Control Measures			
Chemical Hazards		Associated Foods	Control measures
Naturally Occurring:	Scombrototoxin	Primarily associated with tuna fish, mahi-mahi, blue fish, anchovies bonito, mackerel; Also found in cheese	Check temperatures at receiving; store at proper cold holding temperatures; buyer specifications: obtain verification from supplier that product has not been temperature abused prior to arrival in facility.
	Ciguatoxin	Reef fin fish from extreme SE US, Hawaii, and tropical areas; barracuda, jacks, king mackerel, large groupers, and snappers	Ensure fin fish have not been caught: Purchase fish from approved sources. Fish should not be harvested from an area that is subject to an adverse advisory.
	Tetrodoxin	Puffer fish (Fugu; Blowfish)	Do not consume these fish.

	Mycotoxins	Aflatoxin	Corn and corn products, peanuts and peanut products, cottonseed, milk, and tree nuts such as Brazil nuts, pecans, pistachio nuts, and walnuts. Other grains and nuts are susceptible but less prone to contamination.	Check condition at receiving; do not use moldy or decomposed food.
		Patulin	Apple juice products	Buyer Specification: obtain verification from supplier or avoid the use of rotten apples in juice manufacturing.
	Toxic mushroom species		Numerous varieties of wild mushrooms	Do not eat unknown varieties or mushrooms from unapproved source.
Shellfish toxins	Paralytic shellfish poisoning (PSP)	Molluscan shellfish from NE and NW coastal regions; mackerel, viscera of lobsters and Dungeness, tanner, and red rock crabs	Ensure molluscan shellfish are: from an approved source; and properly tagged and labeled.	
	Diarrhetic shellfish poisoning (DSP)	Molluscan shellfish in Japan, western Europe, Chile, NZ, eastern Canada		
	Neurotoxin shellfish poisoning (NSP)	Molluscan shellfish from Gulf of Mexico		
	Amnesic shellfish poisoning (ASP)	Molluscan shellfish from NE and NW coasts of NA; viscera of Dungeness, tanner, red rock crabs and anchovies.		
	Pyrrolizidine alkaloids		Plants food containing these alkaloids. Most commonly found in members of the Borginaceae, Compositae, and Leguminosae families.	Do not consume of food or medicinals contaminated with these alkaloids.

	Phytohaemmagglutinin	Raw red kidney beans (Undercooked beans may be more toxic than raw beans)	Soak in water for at least 5 hours. Pour away the water. Boil briskly in fresh water, with occasional stirring, for at least 10 minutes.
Added Chemicals:	Environmental contaminants: Pesticides, fungicides, fertilizers, insecticides, antibiotics, growth hormones	Any food may become contaminated.	Follow label instructions for use of environmental chemicals. Soil or water analysis may be used to verify safety.
	PCBs	Fish	Comply with fish advisories.
	Prohibited substances (21 CFR 189)	Numerous substances are prohibited from use in human food; no substance may be used in human food unless it meets all applicable requirements of the FD&C Act.	Do not use chemical substances that are not approved for use in human food.
	Toxic elements/compounds Mercury	Fish exposed to organic mercury: shark, tilefish, king mackerel and swordfish. Grains treated with mercury based fungicides	Pregnant women/women of childbearing age/nursing mothers, and young children should not eat shark, swordfish, king mackerel or tilefish because they contain high levels of mercury. Do not use mercury

			containing fungicides on grains or animals.
	Copper	High acid foods and beverages	Do not store high acid foods in copper utensils; use backflow prevention device on beverage vending machines.
	Lead	High acid food and beverages	Do not use vessels containing lead.
	Preservatives and Food Additives: Sulfiting agents (sulfur dioxide, sodium and potassium bisulfite, sodium and potassium metabisulfite) Nitrites/nitrates Niacin	Fresh fruits and Vegetables Shrimp Lobster Wine Cured meats, fish, any food exposed to accidental contamination, spinach Meat and other foods to which sodium nicotinate is added	Sulfiting agents added to a product in a processing plant must be declared on labeling. Do not use on raw produce in food establishments. Do not use more than the prescribed amount of curing compound according to labeling instructions. Sodium nicotinate (niacin) is not currently approved for use in meat or poultry with or without nitrates

			or nitrates.
Flavor enhancers Monosodium glutamate (MSG)	Asian or Latin American food		Avoid using excessive amounts
Chemicals used in retail establishments (e.g., lubricants, cleaners, sanitizers, cleaning compounds, and paints)	Any food could become contaminated		Address through SOPs for proper labeling, storage, handling, and use of chemicals; retain Material Safety Data Sheets for all chemicals.
Allergens	Foods containing or contacted by: <ul style="list-style-type: none"> ▪ Milk ▪ Egg ▪ Fish ▪ Crustacean shellfish ▪ Tree nuts ▪ Wheat ▪ Peanuts ▪ Soybeans 		Use a rigorous sanitation regime to prevent cross contact between allergenic and non-allergenic ingredients.

5. What are Physical Hazards?

Illness and injury can result from foreign objects in food. These physical hazards can result from contamination or poor procedures at many points in the food chain from harvest to consumer, including those within the food establishment. As establishments develop their food safety management systems, Appendix G, Table 3 can be used to aid in the identification of sources of potential physical hazards to the food being prepared, served, or sold. Appendix G, Table 3 provides some examples of common physical hazards.

Appendix G, Table 3. Main Materials of Concern as Physical Hazards and Common Sources^{a, b}		
Material	Injury Potential	Sources
Glass fixtures	Cuts, bleeding; may require surgery to find or remove	Bottles, jars, lights, utensils, gauge covers
Wood	Cuts, infection, choking; may require surgery to remove	Fields, pallets, boxes, buildings
Stones, metal fragments	Choking, broken teeth Cuts, infection; may require surgery to remove	Fields, buildings, machinery, wire, employees
Insulation	Choking; long-term if asbestos	Building materials
Bone	Choking, trauma	Fields, improper plant processing
Plastic	Choking, cuts, infection; may require surgery to remove	Fields, plant packaging materials, pallets, employees
Personal effects	Choking, cuts, broken teeth; may require surgery to remove	Employees

^a Adapted from Corlett (1991).

^b Used with permission, "HACCP principles and Applications", Pierson and Corlett, Eds. 1992. Chapman & Hall, New York, NY.

6. **What is the purpose of the hazard analysis principle?**

The purpose of hazard analysis is to develop a list of food safety hazards that are reasonably likely to cause illness or injury if not effectively controlled.

7. **How is the hazard analysis conducted?**

The process of conducting a hazard analysis involves two stages:

- Hazard Identification
- Hazard Evaluation

Hazard identification can be thought of as a brain storming session. This stage focuses on identifying the food safety hazards that might be present in the food given the food preparation process used, the handling of the food, the facility, and general characteristics of the food itself. During this stage, a review is made of the ingredients used in the product, the activities conducted at each step in the process, the equipment used, the final product, and its method of storage and distribution, as well as the intended use and consumers of the product. Based

on this review, a list of potential biological, chemical, or physical hazards is made at each stage in the food preparation process.

In stage two, the hazard evaluation, each potential hazard is evaluated based on the severity of the potential hazard and its likely occurrence. The purpose of this stage is to determine which of the potential hazards listed in stage one of the hazard analysis warrant control in the HACCP plan. Severity is the seriousness of the consequences of exposure to the hazard. Considerations made when determining the severity of a hazard include understanding the impact of the medical condition caused by the illness, as well as the magnitude and duration of the illness or injury. Consideration of the likely occurrence is usually based upon a combination of experience, epidemiological data, and information in the technical literature. Hazards that are not reasonably likely to occur are not considered in a HACCP plan. During the evaluation of each potential hazard, the food, its method of preparation, transportation, storage, and persons likely to consume the product should be considered to determine how each of these factors may influence the likely occurrence and severity of the hazard being controlled.

Upon completion of the hazard analysis, a list of significant hazards that must be considered in the HACCP plan is made, along with any measure(s) that can be used to control the hazards. These measures, called control measures, are actions or activities that can be used to prevent, eliminate, or reduce a hazard. Some control measures are not essential to food safety, while others are. Control measures essential to food safety like proper cooking, cooling, and refrigeration of ready-to-eat, potentially hazardous foods (time/temperature control for safety foods) are usually applied at critical control points (CCPs) in the HACCP plan (discussed later). The term control measure is used because not all hazards can be prevented, but virtually all can be controlled. More than one control measure may be required for a specific hazard. Likewise, more than one hazard may be addressed by a specific control measure (e.g., proper cooking).

B. Principle #2: Determine Critical Control Points (CCPs)

1. What is the Critical Control Point (CCP)?

A critical control point (CCP) means a point or procedure in a specific food system where loss of control may result in an unacceptable health risk. Control can be applied at this point and is essential to prevent or eliminate a food safety hazard or reduce it to an acceptable level. Each CCP will have one or more control measures to assure that the identified hazards are prevented, eliminated, or reduced to acceptable levels. Common examples of CCPs include cooking, cooling, hot holding, and cold holding of ready-to-eat potentially hazardous foods (time/temperature control for safety foods). Due to vegetative and spore- and toxin-forming bacteria that are associated with raw animal foods, it is apparent that the proper execution of control measures at each of these operational steps is essential to prevent or eliminate food safety hazards or reduce them to acceptable levels.

2. Are quality issues considered when determining CCPs?

CCPs are only used to address issues with product safety. Actions taken on the part of the establishment such as first-in first-out (FIFO) or refrigerating nonpotentially hazardous foods (time/temperature control for safety foods) are to ensure food quality rather than food safety and therefore should not be considered as CCPs unless they serve a dual-purpose of ensuring food safety.

3. Are the CCPs the same for everyone?

Different facilities preparing similar food items may identify different hazards and the CCPs. This can be due to differences in each facility's layout, equipment, selection of ingredients, and processes employed. In mandatory HACCP systems, there may be rigid regulatory requirements regarding what must be designated a CCP. In voluntary HACCP systems, hazard control may be accomplished at CCPs or through prerequisite programs. For instance, one facility may decide that it can best manage the hazards associated with cooling through a standardized procedure in its prerequisite programs rather than at a CCP in its HACCP plan. One tool that can be used to assist each facility in the identification of CCPs unique to its operation is a CCP decision tree.

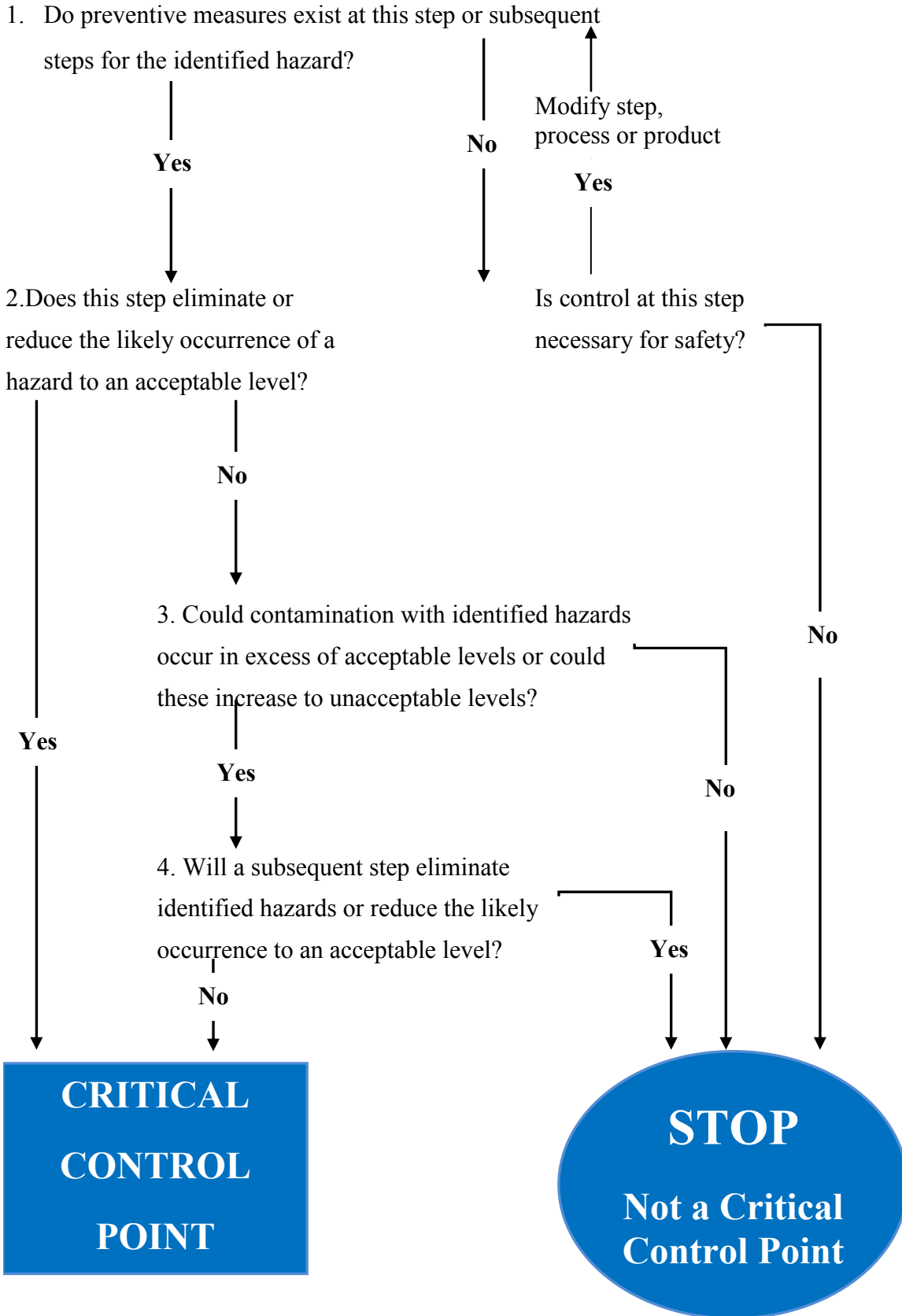

C. Principle #3: Establish Critical Limits

1. What is a critical limit and what is its purpose?

A critical limit is a prescribed parameter (e.g., minimum and/or maximum value) that must be met to ensure that food safety hazards are controlled at each CCP. A critical limit is used to distinguish between safe and unsafe operating conditions at a CCP. Each control measure at a CCP has one or more associated critical limits. Critical limits may be based upon factors like temperature, time, moisture level, water activity (a_w), or pH. They must be scientifically-based and measurable.

2. What are examples of critical limits?

Examples of critical limits are the time/temperature parameters for cooking chicken (165°F for 15 seconds). In this case, the critical limit designates the minimum criteria required to eliminate food safety hazards or reduce them to an acceptable level. The critical limit for the acidification of sushi rice, a pH of ≤ 4.6 , sets the maximum limit for pH necessary to control the growth of spore- and toxin-forming bacteria. Critical limits may be derived from regulatory standards such as the rules and regulations, other applicable guidelines, performance standards, or experimental results.

D. Principle #4: Establish Monitoring Procedures

1. What is the purpose of monitoring?

Monitoring is the act of observing and making measurements to help determine if critical limits are being met and maintained. It is used to determine whether the critical limits that have been established for each CCP are being met.

2. What are examples of monitoring activities?

Examples of monitoring activities include visual observations and measurements of time, temperature, pH, and water activity. If cooking chicken is determined to be a CCP in an operation, then monitoring the internal temperature of a select number of chicken pieces immediately following the cook step would be an example of a monitoring activity. Alternatively, the temperature of an oven or fryer and the time required to reach an internal temperature of 165°F could also be monitored.

3. How is monitoring conducted?

Typically, monitoring activities fall under two broad categories:

- measurements
- observations

Measurements usually involve time and temperature but also include other parameters such as pH. If an operation identifies the acidification of sushi rice as a CCP and the critical limit as the final pH of the product being ≤ 4.6 , then the pH of the product would be measured to ensure that the critical limit is met.

Observations involve visual inspections to monitor the presence or absence of a food safety activity. If date marking is identified as a CCP in a deli operation for controlling *Listeria monocytogenes* in ready-to-eat deli meats, then the

monitoring activity could involve making visual inspections of the date marking system to monitor the sell, consume, or discard dates.

4. How often is monitoring conducted?

Monitoring can be performed on a continuous or intermittent basis. Continuous monitoring is always preferred when feasible as it provides the most complete information regarding the history of a product at a CCP. For example, the temperature and time for an institutional cook-chill operation can be recorded continuously on temperature recording charts.

If intermittent monitoring is used, the frequency of monitoring should be conducted often enough to make sure that the critical limits are being met.

5. Who conducts monitoring?

Individuals directly associated with the operation (e.g., the person in charge of the establishment, chefs, and departmental supervisors) are often selected to monitor CCPs. They are usually in the best position to detect deviations and take corrective actions when necessary. These employees should be properly trained in the specific monitoring techniques and procedures used.

E. Principle #5: Establish Corrective Actions

1. What are corrective actions?

Corrective actions are activities that are taken by a person whenever a critical limit is not met. Discarding food that may pose an unacceptable food safety risk to consumers is a corrective action. However, other corrective actions such as further cooking or reheating a product can be used provided food safety is not compromised. For example, a restaurant may be able to continue cooking hamburgers that have not reached an internal temperature of 155°F for 15 seconds until the proper temperature is met. Clear instructions should be developed detailing who is responsible for performing the corrective actions, the procedures to be followed, and when.

F. Principle #6: Establish Verification Procedures

1. What is verification?

Verification includes those activities, other than monitoring, that determine the validity of the HACCP plan and show that the system is operating according to the plan. Validation is a component of verification which focuses on collecting and evaluating scientific and technical information to determine if the HACCP system, when properly implemented, will effectively control the hazards. Clear instructions should be developed detailing who is responsible for conducting verification, the frequency of verification, and the procedures used.

2. What is the frequency of verification activities? What are some examples of verification activities?

Verification activities are conducted frequently, such as daily, weekly, monthly, and include the following:

- observing the person doing the monitoring and determining whether monitoring is being done as planned
- reviewing the monitoring records to determine if they are completed accurately and consistently
- determining whether the records show that the frequency of monitoring stated in the plan is being followed
- ensuring that corrective action was taken when the person monitoring found and recorded that the critical limit was not met
- validating that the critical limits are achieving the desired results of controlling the identified hazard
- confirming that all equipment, including equipment used for monitoring, is operated, maintained, and calibrated properly.

G. Principle #7: Establish Record Keeping Procedures

1. Why are records important?

Maintaining documentation of the activities in a food safety management system can be vital to its success. Records provide documentation that appropriate corrective actions were taken when critical limits were not met. In the event that an establishment is implicated in a foodborne illness, documentation of activities related to monitoring and corrective actions can provide proof that reasonable care was exercised in the operation of the establishment. Documenting activities provides a mechanism for verifying that the activities in the HACCP plan were properly completed. In many cases, records can serve a dual purpose of ensuring quality and food safety.

2. What types of records are maintained as part of a food safety management system?

There are at least 5 types of records that could be maintained to support a food safety management system:

- records documenting the activities related to the prerequisite programs
- monitoring records
- corrective action records
- verification and validation records
- calibration records.

3. The Process Approach - A Practical Application of HACCP at Retail to Achieve Active Managerial Control

A. Why Focus on HACCP Principles at Retail and Food Service?

FDA recognizes that there are important differences between using HACCP principles in a food safety management system developed for food manufacturing plants and applying these same principles in food safety management system developed for use in retail and food service establishments.

Since the 1980's, operators and regulators have been exploring the use of the HACCP principles in restaurants, grocery stores, institutional care facilities, and other retail food establishments. During this time, much has been learned about how these principles can be used in these varied operations, collectively referred to as retail food establishments. Most of this exploration has centered around the focal question of how to stay true to the NACMCF definitions of HACCP and still make the principles useful to an industry that encompasses the broadest range of conditions.

Unlike industries such as canning, other food processing, and dairy plants, the retail industry is not easily defined by specific commodities or conditions. Consider the following characteristics that retail food establishments share that set them apart from most food processors:

1. Employee and management turnover is exceptionally high in food establishments, especially for entry level positions. This means the many employees or managers have little experience and food safety training must be continuously provided.
2. Many establishments are start-up businesses operating without benefit of a large corporate support structure and having a relatively low profit margin and perhaps less capital to work with than other segments of the food industry.
3. There is an almost endless number of production techniques, products, menu items, and ingredients used which are not easily adapted to a simple, standardized approach. Changes occur frequently and little preparation time is available.

FDA fully recognizes the diversity of retail and food service establishments and their varying in-house resources to implement HACCP. That recognition is combined with an understanding that the success of such implementation is dependent upon establishing realistic and useful food safety strategies that are customized to the operation.

B. What is the Process Approach?

When conducting the hazard analysis, food manufacturers usually use food commodities as an organizational tool and follow the flow of each product. This is a very useful approach for producers or processors since they are usually handling one product at a time. By contrast, in retail and food service operations, foods of all types are worked together to produce the final product. This makes a different approach to the hazard analysis necessary. Conducting the hazard analysis by using the food preparation processes common to a specific operation is often more efficient and useful for retail and food service operators. This is called the "process approach" to HACCP.

The process approach can best be described as dividing the many food flows in an establishment into broad categories based on activities or stages in the preparation of the food, then analyzing the hazards, and placing managerial controls on each grouping.

C. What are the three food preparation processes most often used in retail and food service establishments and how are they determined?

The flow of food in a retail or food service establishment is the path that food follows from receiving through service or sale to the consumer. Several activities or stages make up the flow of food and are called operational steps. Examples of operational steps include receiving, storing, preparing, cooking, cooling, reheating, holding, assembling, packaging, serving, and selling. The terminology used for operational steps may differ between food service and retail food store operations.

Most food items produced in a retail or food service establishment can be categorized into one of three preparation processes based on the number of times the food passes through the temperature danger zone between 41°F and 135°F:

- **Process 1: Food Preparation with No Cook Step**
Example flow: Receive - Store - Prepare - Hold - Serve
(other food flows are included in this process, but there is no cook step to destroy pathogens)
- **Process 2: Preparation for Same Day Service**
Example flow: Receive - Store – Prepare - Cook – Hold - Serve
(other food flows are included in this process, but there is only one trip through the temperature danger zone)
- **Process 3: Complex Food Preparation**
Example flow: Receive - Store - Prepare - Cook – Cool – Reheat – Hot Hold – Serve
(other food flows are included in this process, but there are always two or more complete trips through the temperature danger zone)

A summary of the three food preparation processes in terms of number of times through the temperature danger zone can be depicted in a Danger Zone diagram. Although foods produced using process 1 may enter the danger zone, they do not pass all the way through it. Foods that go through the danger zone only once are classified as Same Day Service, while foods that go through more than once are classified as Complex food preparation.

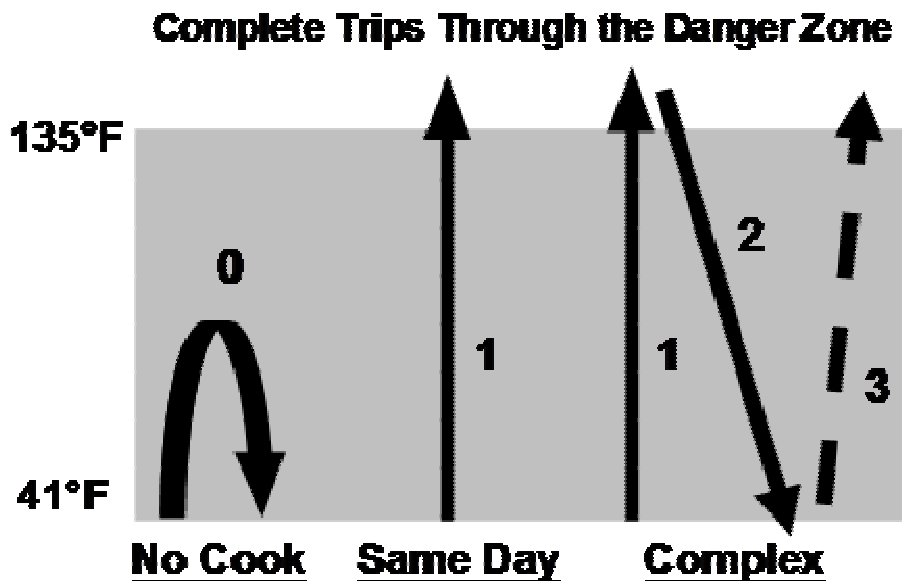

The three food preparation processes conducted in retail and food service establishments are not intended to be all-inclusive. For instance, quick service facilities may have "cook and serve" processes specific to their operation. These processes are likely to be different from the "Same Day Service" preparation processes in full service restaurants since many of their foods are generally cooked and hot held before service. In addition, in retail food stores, operational steps such as packaging and assembly may be included in all of the food preparation processes before the product is sold to the consumer. It is also very common for a retail or food service operator to use multiple food preparation processes to create a single menu item.

D. How is a hazard analysis conducted in process HACCP?

In the process approach to HACCP, conducting a hazard analysis on individual food items is time and labor intensive and is generally unnecessary. Identifying and controlling the hazards in each food preparation process achieves the same control of risk factors as preparing a HACCP plan for each individual product.

Example: An establishment has dozens of food items (including baked chicken and baked meatloaf) in the "Preparation for Same Day Service" category. Each of the food items may have unique hazards, but regardless of the individual hazards, control via proper cooking and holding will generally ensure the safety of all of the foods in this category. An illustration of this concept follows:

1. Even though they have unique hazards, baked chicken and meatloaf are items frequently grouped in the "Same Day Service" category (Process 2).
2. Salmonella spp. and Campylobacter, as well as spore-formers, such as Bacillus cereus and Clostridium perfringens, are significant biological hazards in chicken.

3. Significant biological hazards in meatloaf include Salmonella spp., E. coli O157:H7, Bacillus cereus, and Clostridium perfringens.
4. Despite their different hazards, the control measure used to kill pathogens in both these products is cooking to the proper temperature.
5. Additionally, if the products are held after cooking, then proper hot holding or time control is also required to prevent the outgrowth of spore-formers that are not destroyed by cooking.

As with product-specific HACCP, critical limits for cooking remain specific to each food item in the process. In the scenario described above, the cooking step for chicken requires a final internal temperature of 165°F for 15 seconds to control the pathogen load for Salmonella spp. Meatloaf, on the other hand, is a ground beef product and requires a final internal temperature of 155°F for 15 seconds to control the pathogen load for both Salmonella spp. and E. coli O157:H7. Some operational steps such as refrigerated storage or hot holding have critical limits that apply to all foods.

Appendix G, Table 4 further illustrates this concept. Note that the only unique control measure applies to the critical limit of the cooking step for each of the products. Other food safety hazards and control measures may exist that are not depicted here:

Appendix G, Table 4: Examples of Hazards and Control Measures for Same Day Service Items		
Process 2: Preparation for Same Day Service		
Example Products	Baked Meatloaf	Baked Chicken
Example Biological Hazards	Salmonella spp.	Salmonella spp.
	E. coli O157:H7	Campylobacter
	Clostridium perfringens	Clostridium perfringens
	Bacillus cereus	Bacillus cereus
	Various fecal-oral route pathogens	Various fecal-oral route pathogens
Example Control Measures	Refrigeration at 41°F or below	Refrigeration at 41°F or below
	Cooking at 155°F for 15 seconds	Cooking at 165°F for 15 seconds
	Hot Holding at 135°F or above OR Time Control	Hot Holding at 135°F or above OR Time Control
	Good personal hygiene (No bare hand contact with RTE* food, proper handwashing, exclusion/restriction of ill employees)	Good personal hygiene (No bare hand contact with RTE* food, proper handwashing, exclusion/restriction of ill employees)

*RTE = ready-to-eat food

E. How is the process approach helpful to industry in determining the measures that must be implemented to actively manage the foodborne illness risk factors that result in out-of-control hazards?

Even though variations in foods and in the three food preparation process flows used to prepare them are common, the control measures will generally be the same based on the number of times the food goes through the temperature danger zone. Several of the most common control measures associated with each food preparation process are discussed in this Appendix. Retail or food service establishments should use these simple control measures as the core of their food safety management systems; however, there may be other risk factors unique to an operation or process that are not listed here. Each operation should be evaluated independently.

In developing a voluntary food safety management system, active managerial control of risk factors common to each process can be achieved by implementing control measures at certain operational steps designated as critical control points (CCPs) or by implementing prerequisite programs. This is explained in more detail in the Operator's Manual discussed in Part 5 of this Appendix.

F. Facility-wide Considerations

In order to have active managerial control over personal hygiene and cross-contamination, certain control measures must be implemented in all phases of the operation. All of the following control measures should be implemented regardless of the food preparation process used:

- **No bare hand contact with ready-to-eat foods (or use of a pre-approved, alternative procedure)** to help prevent the transfer of viruses, bacteria, or parasites from hands to food
- **Proper handwashing** to help prevent the transfer of viruses, bacteria, or parasites from hands to food
- **Restriction or exclusion of ill employees** to help prevent the transfer of viruses, bacteria, or parasites from hands to food
- **Prevention of cross-contamination** of ready-to-eat food or clean and sanitized food-contact surfaces with soiled cutting boards, utensils, aprons, etc., or raw animal foods.

G. Food Preparation Process 1 – Food Preparation with No Cook Step

Example Flow: RECEIVE → STORE → PREPARE → HOLD → SERVE

Several food flows are represented by this particular process. Many of these food flows are common to both retail food stores and food service facilities, while others only apply to retail operations. Raw, ready-to-eat food like sashimi, raw oysters, and salads are grouped in this category. Components of these foods are received raw and will not be cooked before consumption.

Foods cooked at the processing level but that undergo no further cooking at the retail level before being consumed are also represented in this category. Examples of these

kinds of foods are deli meats, cheeses, and other pasteurized dairy products (such as yogurt). In addition, foods that are received and sold raw but are to be cooked by the consumer after purchase, e.g., hamburger meat, chicken, and steaks, are also included in this category.

All the foods in this category lack a cook step while at the retail or food service facility; thus, there are no complete trips through the danger zone. Purchase specifications can be required by the retail or food service establishment to ensure that foods are received as safe as possible. Without a kill step to destroy pathogens, preventing further contamination by ensuring that employees follow good hygienic practices is an important control measure.

Cross-contamination must be prevented by properly storing ready-to-eat food away from raw animal foods and soiled equipment and utensils. Foodborne illness may result from ready-to-eat food being held at unsafe temperatures for long periods of time due to the outgrowth of bacteria.

In addition to the facility-wide considerations, a food safety management system involving this food preparation process should focus on ensuring active managerial control over the following:

- **Cold holding or using time alone** to control bacterial growth and toxin production
- **Food source** (e.g., shellfish due to concerns with viruses, natural toxins, and *Vibrio* and for certain marine finfish intended for raw consumption due to concerns with ciguatera toxin)
- **Receiving temperatures** (e.g., certain species of marine finfish due to concerns with scombrototoxin)
- **Date marking** of ready-to-eat PHF (TCS food) held for more than 24 hours to control the growth of psychrophiles such as *Listeria monocytogenes*
- **Freezing** certain species of fish intended for raw consumption due to parasite concerns
- **Cooling** from ambient temperature to prevent the outgrowth of spore-forming or toxin-forming bacteria.

H. Food Preparation Process 2 - Preparation for Same Day Service

Example Flow: RECEIVE → STORE → PREPARE → COOK → HOLD → SERVE

In this food preparation process, food passes through the danger zone only once in the retail or food service facility before it is served or sold to the consumer. Food is usually cooked and held hot until served, e.g., fried chicken, but can also be cooked and served immediately. In addition to the facility-wide considerations, a food safety management system involving this food preparation process should focus on ensuring active managerial control over the following:

- **Cooking** to destroy bacteria and parasites
- **Hot holding or using time alone** to prevent the outgrowth of spore-forming bacteria.

Approved food source, proper receiving temperatures, and proper cold holding before cooking would also be important if dealing with certain marine finfish due to concerns with ciguatera toxin and scombrototoxin.

I. Food Preparation Process 3 – Complex Food Preparation

Example Flow: RECEIVE → STORE → PREPARE → COOK → COOL → REHEAT
HOT HOLD → SERVE

Foods prepared in large volumes or in advance for next day service usually follow an extended process flow. These foods pass through the temperature danger zone more than one time; thus, the potential for the growth of spore-forming or toxigenic bacteria is greater in this process. Failure to adequately control food product temperatures is one of the most frequently encountered risk factors contributing to foodborne illness. Food handlers should minimize the time foods are at unsafe temperatures.

In addition to the facility-wide considerations, a food safety management system involving this food preparation process should focus on ensuring active managerial control over the following:

- **Cooking** to destroy bacteria and parasites
- **Cooling** to prevent the outgrowth of spore-forming or toxin-forming bacteria
- **Hot and cold holding or using time alone** to control bacterial growth and toxin formation
- **Date marking** of ready-to-eat PHF (TCS food) held for more than 24 hours to control the growth of psychrophiles such as *Listeria monocytogenes*
- **Reheating** for hot holding, if applicable.

Approved food source, proper receiving temperatures, and proper cold holding before cooking would also be important if dealing with certain marine finfish due to concerns with ciguatera toxin and scombrototoxin.

4. FDA Retail HACCP Manuals

A. What guidance has been developed by FDA to assist operators of retail and food service establishments in achieving active managerial control of foodborne illness risk factors?

FDA, in partnership with Federal, State, and local regulators, industry, academia, and consumers, has written a guidance document entitled, "[Managing Food Safety: A Manual for the Voluntary Use of HACCP Principles for Operators of Food Service and Retail Establishments](#)".⁷ Commonly referred to as the "Operator's Manual," this document is designed to assist operators with developing or enhancing food safety management systems based on the process approach to HACCP. The manual presents a step-by-step procedure for writing and voluntarily implementing a food safety management system based on the principles of HACCP. The desired outcome is an operator who employs a preventive rather than a reactive strategy to food safety.

The Operator's Manual embodies FDA's current thinking on the application of HACCP principles at retail. It advocates the voluntary use of HACCP principles using the process approach as a practical and effective means of reducing the occurrence of foodborne illness risk factors leading to out-of-control hazards. The Operator's Manual is strictly for the voluntary implementation of HACCP principles at retail and should not be used to develop HACCP plans that are required through Federal, State, or local regulations, ordinances, or laws.

B. What guidance has been developed by FDA to assist regulators of retail and food service establishments in assessing industry's active managerial control of foodborne illness risk factors?

FDA has written a document for regulators of retail and food service establishments entitled, "Managing Food Safety: A Regulator's Manual for Applying HACCP Principles to Risk-Based Retail and Food Service Inspections and Evaluating Voluntary Food Safety Management Systems"⁸. Commonly referred to as the "Regulator's Manual," this document was written to provide a risk-based inspectional "roadmap" for evaluating the degree of active managerial control an operator has over foodborne illness risk factors.

In addition, the manual advocates the use of voluntary intervention strategies, including the development of food safety management systems or risk control plans to bring about a long-term behavior change that will result in a reduction in the occurrence of risk factors. In cases where an operator may want their inspector to provide them with feedback on their voluntarily-implemented food safety management system, the manual provides regulators with information on how to validate and verify an existing system.

Annex 5 of the Food Code outlines the basis for conducting successful risk-based inspections and is provided to assist industry in achieving active managerial control of foodborne illness risk factors as outlined in the draft Recommended National Retail Food Regulatory Program Standards and the Regulator's Manual.

5. Advantages of the HACCP Principles

A. What advantages does using HACCP principles offer operators of retail and food service establishments?

Rather than relying solely on periodic feedback from inspections by regulatory agencies, an establishment operator who implements a food safety management system based on HACCP principles emphasizes continuous problem solving and prevention. Additionally, HACCP enhances and encourages communication between industry and regulators.

A food safety management system based on HACCP principles offers many other advantages to industry. One advantage is that such a system may provide a method for achieving active managerial control of multiple risk factors associated with an entire operation. Other advantages include:

- Reduction in product loss
- Increase in product quality
- Better inventory control

- Consistency in product preparation
- Increase in profit
- Increased employee awareness and participation in food safety.

B. What advantage does using HACCP principles offer regulators of retail and food service establishments?

Traditional inspections are relatively resource-intensive, inefficient, and reactive rather than preventive in nature. Using traditional inspection techniques allows for a satisfactory "snapshot" assessment of the requirements of the code at the time of the inspection. Unfortunately, unless an inspector asks questions and inquires about the activities and procedures being utilized by the establishment even at times when the inspector is not there, there is no way to know if an operator is achieving active

With the limited time often available for conducting inspections, regulators must focus their attention on those areas that clearly have the greatest impact on food safety – foodborne illness risk factors. By knowing that there are only a few control measures that are essential to food safety and focusing on these during the inspection, an inspector can assess the operator's active managerial control of the foodborne illness risk factors.

Regulators can provide invaluable feedback to an operator through their routine inspections. This is especially useful when utilizing a risk-based approach. By incorporating HACCP principles into routine inspections, an inspector can provide an operator with the constructive input needed to establish the control system necessary to bring the foodborne illness risk factors back under continuous control.

6. Summary

In order to make a positive impact on foodborne illness, retail and food service operators must achieve active managerial control of the risk factors contributing to foodborne illness. Combined with basic sanitation, employee training, and other prerequisite programs, the principles of HACCP provide an effective system for achieving this objective.

The goal in applying HACCP principles in retail and food service is to have the operator take purposeful actions to ensure safe food. The process approach simplifies HACCP principles for use in retail and food service. This practical and effective method of hazard control embodies the concept of active managerial control by providing an on-going system of simple control measures that will reduce the occurrence of risk factors that lead to out-of-control hazards.

The role of retail and food service regulatory professionals is to conduct risk-based inspections using HACCP principles to assess the degree of control industry has over the foodborne illness risk factors. Regulators can assist industry in achieving active managerial control of risk factors by using a risk-based inspection approach to identify strengths and weaknesses and suggesting possible solutions and improvements.

7. Acknowledgements

Much of this Appendix is adapted from the National Advisory Committee on Microbiological Criteria for Foods, Hazard Analysis and Critical Control Point Principles and Guidelines, adopted August 14, 1997.

The physical hazards table (Table 3) was provided courtesy of "Overview of Biological, Chemical, and Physical Hazards" in "HACCP Principles and Applications," Merle Pierson and Donald A. Corlett, Jr. (Eds.), 1992. p. 8-28. Chapman and Hall, New York.

Based on a recommendation from the Retail HACCP Committee of the Conference for Food Protection, the two HACCP Manuals have been endorsed by the Conference.

8. Resources and References

A. Articles

Bryan, Frank "Hazard Analyses of Street Foods and Considerations for Food Safety." Dairy, Food and Environmental Sanitation, February 1995, pp. 64-69.

Bryan, Frank "HACCP: Present Status and Future in Contribution to Food Safety." Dairy, Food & Environmental Sanitation, November 1994, pp. 650-655.

Bryan, Frank "Procedures for Local Health Agencies to Institute a Hazard Analysis Critical Control Point Program for Food Safety Assurance in Food Service Operations." Journal of Environmental Health, March/April 1985, pp. 241-245.

Bryan, Frank "Hazard Analysis of Food Service Operation." Food Technology, February 1981, pp. 78-87.

Bryan, Frank "Hazard Analysis Critical Control Point Approach: Epidemiologic Rationale and Application to Food Service Operations." Journal of Environmental Health, August 1981, pp. 7-14.

Bryan, Frank "Factors that Contribute to Outbreaks of Foodborne Disease." Journal of Food Protection, October 1978, pp. 816-827.

Briley and Klaus "Using Risk Assessment as a Method of Determining Inspection Frequency." Dairy and Food Sanitation, December 1985, pp. 468-474.

Centers for Disease Control and Prevention. Surveillance for Foodborne Disease Outbreaks – United States, 1993-1997. Morbidity Mortality Weekly Report, #49 (SS01), USPHS, March 17, 2000, pp. 1-51.

Mead, P.S., Slutsker, L., Dietz, V., McCraig, L.F., Bresee, J.S., Shapiro, C., Griffin, P.M., Tauxe, R.V. "Food-related Illness and Death in the United States⁹." Emerg. Infect. Dis. Vol. 5, No. 5, 1999.

National Advisory Committee on Microbiological Criteria for Food (NACMCF). 1997 Hazard Analysis and Critical Control Point System, USDA - FSIS Information Office, 1997.

National Advisory Committee on Microbiological Criteria for Food (NACMCF). 1992 Hazard Analysis and Critical Control Point System, *Int. J. Food Microbiology*, 16:1-23.

National Food Processors Assoc. "HACCP Implementation: A Generic Model for Chilled Foods." *Journal of Food Protection*, December, 1993, pp. 1077-1084.

President's Council on Food Safety. The Food Safety Strategic Plan, 2001. Ch. 2: Vision, Goals, Objectives, and Action items.

Silliker, John, Ph.D. "Microbiological Testing and HACCP Programs." *Dairy, Food and Environmental Sanitation*, October 1995, pp. 606-610.

Stier, R.F., and Blumenthal, M.M., Ph.D. "Will HACCP be Carrot or Stick." *Dairy, Food and Environmental Sanitation*, October 1995, pp. 616 - 620.

Tisler, J.M. "The Food and Drug Administration's Perspective on HACCP," *Food Technology*, June 1991, pp. 125-127.

Tompkin, R.B. "The Use of HACCP in the Production of Meat and Poultry Products." *Journal of Food Protection*, September 1990, pp. 795-803.

Weingold, S.E., et al. "Use of Foodborne Disease Data for HACCP Risk Assessment." *Journal of Food Protection*, September 1994, pp. 820-830.

B. Books

Corlett, D.A. and Pierson, M.D. *HACCP, Principles & Applications*, ed., Chapman and Hall, New York, 1992.

Diseases Transmitted by Foods, 2nd ed., Centers for Disease Control, USPHS, 1982.

Fellows, P.J. *Food Processing Technology, Principles and Practice*, Ellis Horwood, New York, 1990.

Fennema, O.R. *Food Chemistry*, 2nd ed., Marcel Dekker, Inc., New York, 1985.

Foodborne Diseases, ed. D.O. Cliver, Academic Press, San Diego, California, 1990.

HACCP Reference Book, National Restaurant Assoc., The Educational Foundation, Chicago, 1994.

Heymann, David L. MD, (Ed.), 2004. *Control of Communicable Diseases Manual*, 18th Ed., American Public Health Association, Washington D.C.

Jay, J.M. *Modern Food Microbiology*, 4th ed., Van Nostrand Reinhold, New York, 1992.

Potter, N.N., J.H. Hotchkiss, 1999. Food Science, 5th ed., Kluwer Academic Publishers, Secaucus, NJ.

Stevenson, K.E., D.T. Bernard, 1999. HACCP: A Systematic Approach to Food Safety, 3rd ed., Food Processors Institute, Washington, DC, 1999.

C. **FDA Publications**

Fish and Fishery Products - Code of Federal Regulations, Title 21, Part 123 Fish and Fishery Products.

Fish and Fishery Products Hazards and Controls Guide, Third Edition, June 2001. Food and Drug Administration, Washington, D.C. May be purchased from:

National Technical Information Service,
U.S. Department of Commerce,
703-487-4650.

The **Fish and Fishery Products Hazards and Controls Guide**¹⁰. Single copies may be obtained as long as supplies last from FDA district offices and from:

U.S. Food and Drug Administration
Office of Seafood
5100 Paint Branch Parkway
College Park, MD 20740-3835

Food and Drug Administration/U.S. Public Health Service, 2003. National Shellfish Sanitation Program Guide for the Control of Molluscan Shellfish¹¹.

Report of the FDA Retail Food Program Database of Foodborne Illness Risk Factors, 2000.¹²

FDA Report on the Occurrence of Foodborne Illness Risk Factors in Selected Institutional Foodservice, Restaurant, and Retail Food Store Facility Types (2004).

Two Typical Flow Diagrams

Flow Chart 1

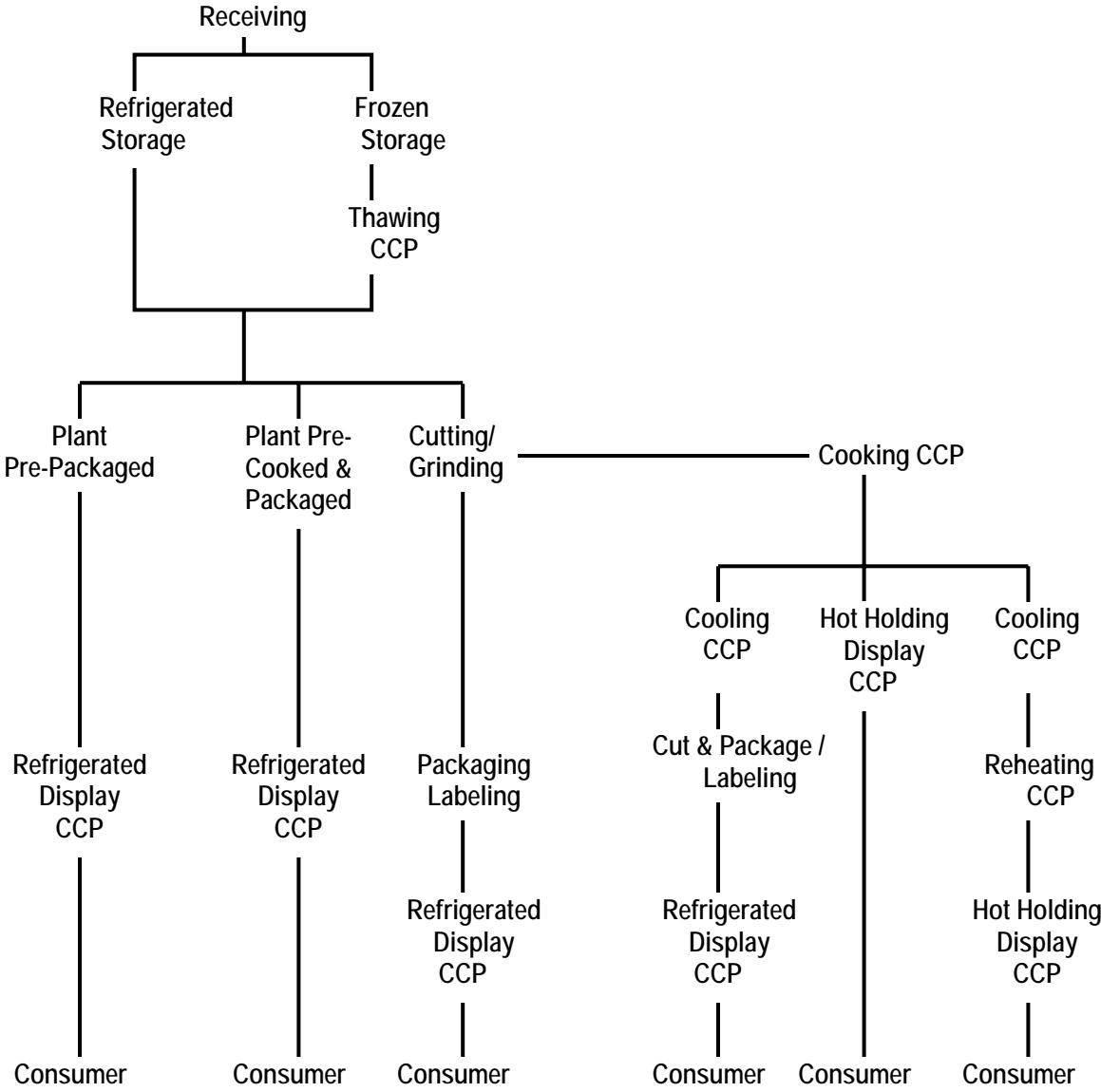

Flow Chart 2

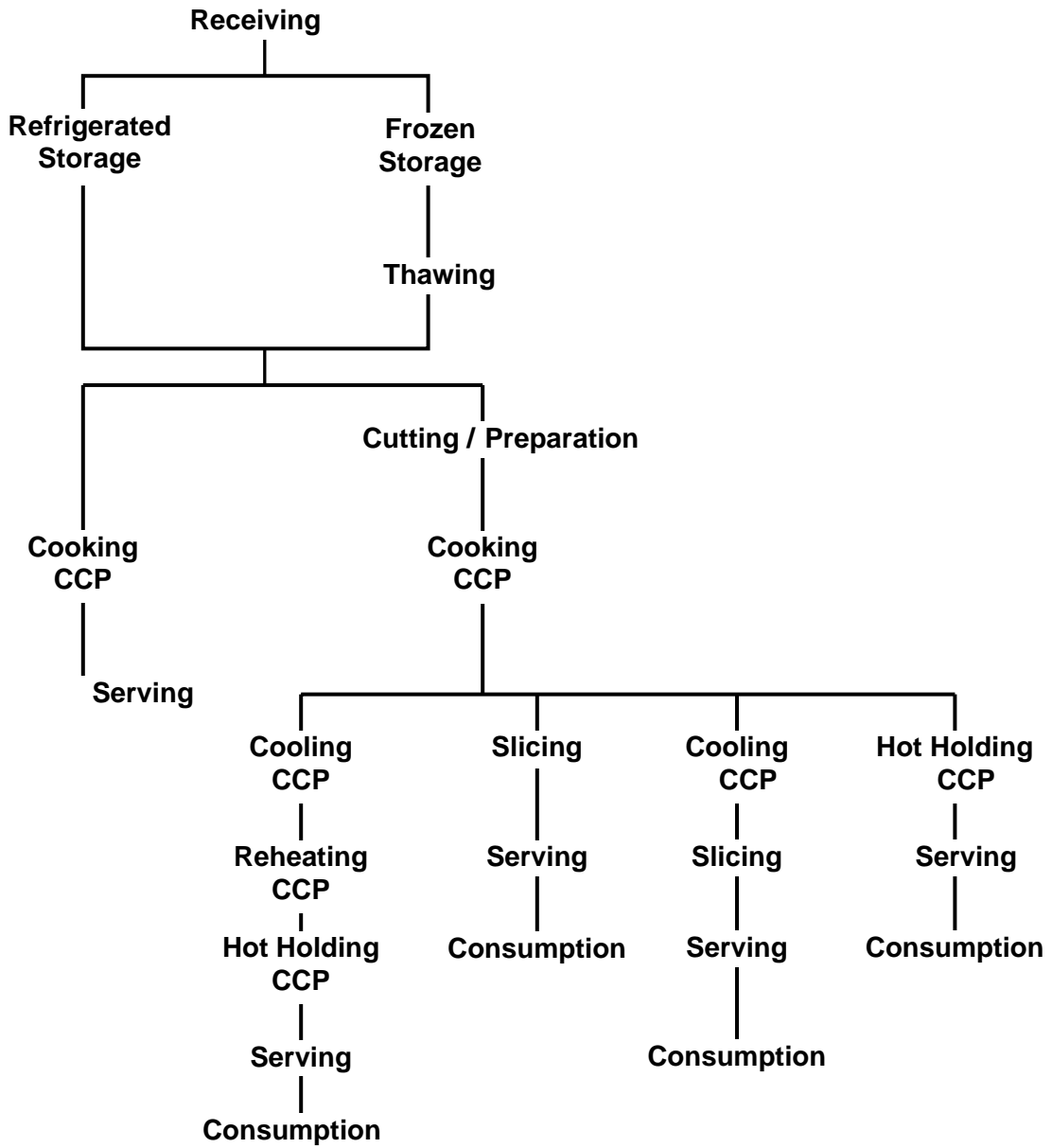

Appendix H - RETAIL FOOD STORE SANITATION ACT

25-4-1301. Legislative declaration. The general assembly hereby declares that the sanitary protection of bulk foods and the sanitary maintenance of equipment used to display and dispense bulk foods are matters of statewide concern and are affected with a public interest and that the provisions of this part 13 are enacted in the exercise of the police powers of this state for the purpose of protecting the health, peace, safety, and general welfare of the people of this state.

25-4-1302. Definitions. As used in this part 13, unless the context otherwise requires:

(1) "Bulk foods" means unpackaged or unwrapped foods, either processed or unprocessed, in aggregate containers from which quantities desired by the consumer are withdrawn. "Bulk foods" does not include fresh fruits, fresh vegetables, nuts in the shell, salad bar, bulk pet foods, potentially hazardous foods, and bulk nonfood items.

(2) "Department" means the department of health.

(3) "Display area" means a location including physical facilities and equipment, where bulk foods are offered for customer self-service.

(4) "Potentially hazardous foods" includes any food that consists in whole or in part, of milk or milk products, eggs, meat, poultry, fish, shellfish, edible crustacea, or other food products or ingredients, including synthetic ingredients, in a form capable of supporting rapid and progressive growth of infectious or toxigenic microorganisms. This term does not include refrigerated, clean, whole, uncracked, odor-free shell eggs.

(5) "Product module" means a food-contact container (multiuse or single-service) designed for customer self-service of bulk foods by either direct or indirect means.

(6) "Servicing area" means a designated location equipped for cleaning, sanitizing drying, or refilling product modules or for preparing bulk foods.

25-4-1303. Labeling - product modules - take-home containers. (1) product modules shall be labeled with either:

(a) The manufacturer's or processor's bulk food container labeling plainly in view; or

(b) A counter card, a counter sign, or any other appropriate device bearing prominently and conspicuously the common name of the product, a list of ingredients in their proper order of predominance, and a declaration of artificial color or flavor and chemical preservatives if contained in the product.

(2) any unpack aged bulk food need not comply with the labeling requirements of this section if the unpackaged bulk food is manufactured on the premises of a store or manufactured by the same store at the different location and if the manufactured bulk food is offered for retail sale on the store's premises and if there are no state requirements.

(3) Labels or marking pens shall be available to customers to identify their take-home containers with the common name of the product unless the product is readily identifiable on sight.

25-4-1304. Bulk food protection. (1) Bulk foods and product modules shall be protected. from contamination during , display, customer self-service, refilling, and storage.

(2) Containers of bulk pet foods and bulk nonfood items shall be separated from product modules by a barrier or open space.

(3) Bulk foods returned to stores by customers shall not be offered for resale.

(4) Only containers provided by stores in their display areas shall be filled with bulk foods; except that any customer may fill or refill his own containers with vended or dispensed water; however, the risk that the customer's own container is unsafe, unpure, contaminated, or in a non sterile condition when it is filled or refilled by the customer, shall be borne solely by the customer, and, except for warranties, no liability shall attach thereto to the manufacturer, seller, or dispenser of such container.

25-4-1305. Bulk food display. (1) Bulk foods shall be dispensed only from product modules which are protected by close-fitting, individual covers. If any product module is to be opened by customers, the cover shall be self-closing and shall remain close when not in use.

(2) Customer access to bulk foods in product modules shall be limited and controlled to avoid the introduction of contaminants. All product modules shall have an access height of thirty inches or more above the floor and a depth of eighteen inches or less.

(3) Potentially hazardous foods shall not be made available for customer self-service.

25-4-1306. Dispensing utensils. (1) Manual handling of bulk foods by customers during dispensing shall be discouraged. Mechanical dispensing devices shall be used, including gravity dispensers, pumps, extruders, and augers. Manual dispensing utensils shall also be used, including tongs, scoops, ladles, and spatulas.

(2) If the dispensing devices and utensils listed in subsection (1) of this section do not discourage manual customer handling of bulk foods, such bulk foods must be wrapped or sacked prior to display.

(3) Manual dispensing utensils shall be protected against becoming contaminated and serving as vehicles for introducing contamination into bulk foods. A tether of easily cleanable material shall be attached to such a utensil and shall be of such length that the utensil cannot contact the floor. A sleeve or protective housing attached or adjacent to the display unit shall be available for storing a utensil when not in use.

(4) Ladles and spatulas shall be stored in bulk foods with handles extending to the outside of product modules. Handles shall not prevent lids from being self-closing.

25-4-1307. Materials. Product modules and utensils shall be constructed of safe materials and shall be corrosion resistant, nonabsorbent, smooth, easily cleanable, and durable under conditions of normal use. Wood shall not be used as a food-contact surface.

25-4-1308. Food-contact surfaces. Product modules, lids, dispensing units, and utensils shall be designed and fabricated to meet the requirements for food-contact surfaces, as provided in section 25-4-1307.

25-4-1309. Non-food-contact surfaces. Surfaces of product module display units, tethers, and display equipment which are not intended for food contact but which are exposed to splash, food debris, or other

soiling shall be designed and fabricated to be smooth, cleanable, durable under conditions of normal use, and free of unnecessary ledges, projections, and crevices. The materials for non-food-contact surfaces shall be nonabsorbent or made nonabsorbent by being finished and sealed with a cleanable coating.

25-4-1310. Accessibility. Individual product modules shall be designed to be easily removable from a display unit for servicing unless the product modules are so designed and fabricated that they can be effectively cleaned and sanitized when necessary through a manual in-place cleaning procedure that will not contaminate or otherwise adversely affect bulk foods or equipment in any adjoining display areas.

25-4-1311. Equipment sanitization. (1) Tongs, scoops, ladles, spatulas, and other appropriate utensils and tethers used by customers shall be cleaned and sanitized at least daily or at more frequent intervals based on the type of bulk food and the amount of food particle accumulation of soiling.

(2) When soiled, product modules, lids, and other equipment shall be cleaned and sanitized prior to restocking or at intervals of a schedule based on the type of bulk food and the amount of food particle accumulation.

(3) Food-contact surfaces shall be cleaned and sanitized immediately if contamination is observed or suspected.

(4) Facilities and equipment shall be available, either in a servicing area or in place, to provide for the proper cleaning and sanitizing of all food-contact surfaces, including product modules, lids, and dispensing utensils.

(5) Take-home containers, including but not limited to bags, cups, and lids, which are provided in a display area for customer use shall be stored and dispensed in a sanitary manner.

25-4-1312. Violation - Penalty. Any retail food store owner violating any of the provisions of this part 13 is guilty of a misdemeanor and, upon conviction thereof, shall be punished by a fine of not more than five hundred dollars, or by imprisonment in the county jail for not more than ninety days, or by both such fine and imprisonment. It is the duty of the district attorneys of the several districts of this state to prosecute for violations of this part 13 as for other crimes and misdemeanors.

25-4-1313. Rules and regulations. The department has the power to promulgate rules and regulations for the implementation of this part 13.

25-4-1314. Limitation. The provisions of this part 13 shall be expressly limited to retail food store outlets.

APPENDIX I - Equipment Investigation Report

Section 4-101 of the Colorado Retail Food Establishment Rules and Regulation specify all equipment, utensils and single-service articles shall be fabricated with safe materials; be of commercial design, that is certified or classified by an American National Standards Institute (ANSI) accredited certification program, such as the National Sanitation Foundation (NSF), Underwriters Laboratories (UL) sanitation standards, Environmental Testing Laboratories, Inc. (ETL) sanitation standards, Baking Industry Sanitation Standards Committee (BISSC), or other comparable design criteria as approved by the Department during a standardized equipment review.

If a retail food establishment intends to have any equipment, utensils and single-service articles approved by the Department, the approval will be based upon submission of the following information to be provided to the local public health agency and/or the Colorado Department of Public Health and Environment for evaluation.

**COLORADO DEPARTMENT OF PUBLIC HEALTH AND ENVIRONMENT
4300 CHERR CREEK DRIVE SOUTH
DENVER, CO 80246-1530**

EQUIPMENT INVESTIGATION REPORT	
1. LOCATION (STATE AND COUNTY)	
2. RECOMMENDATION <input type="checkbox"/> ACCEPT <input type="checkbox"/> REJECT	
3. PREPARED BY NAME _____ TITLE _____ AGENCY _____ SIGNATURE _____ DATE _____	
4. NAME/TITLE/ORGANIZATION REQUESTING INVESTIGATION	5. DATE OF REQUEST
6. NAME AND ADDRESS OF MANUFACTURER	7. DATE OF INVESTIGATION
8. NAME AND TITLE OF CONTACT	
EQUIPMENT INFORMATION	
9. TRADE NAME	10. MODEL NUMBER
11. DESCRIPTION OF EQUIPMENT (CHECK APPROPRIATE LINE AND DESCRIBE) <input type="checkbox"/> PROTOTYPE <input type="checkbox"/> PRODUCTION <input type="checkbox"/> IN USE <input type="checkbox"/> OTHER	
12. SPECIFIC USE OF EQUIPMENT	
13. FOOD-CONTACT SURFACE MATERIAL TYPE (CHECK APPROPRIATE LINE AND DESCRIBE) <input type="checkbox"/> METAL _____ <input type="checkbox"/> PAINT _____ <input type="checkbox"/> RUBBER _____ <input type="checkbox"/> PLASTIC _____	

14. PLEASE ATTACH A SPECIFICATION SHEET OR A BLUE PRINT DRAWING OF EQUIPMENT

15. RESULTS OF INVESTIGATION

16. ACTION TAKEN

17. COMMENTS